

**HI 2201LT Loop Powered Level Weight Transmitter For  
Hazardous Areas  
HI 2204LT Loop Powered Level Weight Transmitter**

**OPERATION AND INSTALLATION  
MANUAL**

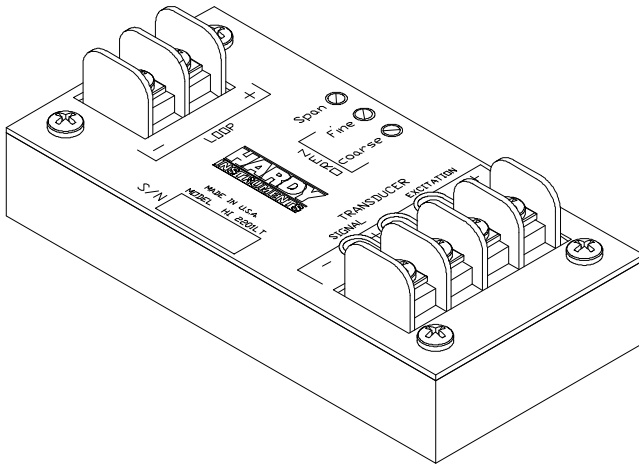

**Corporate Headquarters**  
9440 Carroll Park Drive, Suite 150  
San Diego, CA 92121  
Phone: (858) 278-2900  
FAX: (858) 278-6700  
Web-Site: <http://www.hardyinst.com>

Hardy Instruments Document Number: 0596-0138-01 Rev E  
Copyright November 1999 Hardy Instruments, Inc. All Rights Reserved. Printed in the U.S.A. (941028)



**Table of Contents**

<b>Overview</b>	<b>-1</b>
<b>Specifications</b>	<b>-2</b>
Physical Dimensions	-2
Power Requirement	-2
Load Cell Excitation	-2
Zero Offset Range	-2
Sensitivity	-2
Linearity	-2
Operating Temperature Range	-2
Temperature Coefficient	-3
Signal Current Ripple	-3
Power Supply Rejection	-3
Approvals (HI 2201LT Only)	-3
Approvals HI 2201LT & HI 2204LT	-3
<b>Installation</b>	<b>-3</b>
Junction Box with Strain Gage Summing Board (HI 2201LT-A3 or HI 2201LT-A5)	-3
Input - Strain Gage Transducer	-4
Output/Power Loop	-4
Earth Ground and Signal Return	-6
Precautions on Grounding	-7
Isolation	-7
<b>Calibration</b>	<b>-7</b>
Calibration Controls	-8
Coarse (Zero)	-8
Fine (Zero)	-8
Span	-8
Calibration Procedures	-8
Example	-9
<b>Trouble Shooting Procedures</b>	<b>-10</b>
Malfunction: No Output	-10
Malfunction: No Change in Input	-10
Malfunction: Output Drifts	-10
<b>Factory Mutual (FM) Approval (HI 2201LT Only)</b>	<b>-11</b>



## **Overview**

The model HI 2204LT Loop Powered Level Weight Transmitter and model HI 2201LT Loop Powered Level Weight Transmitter for Hazardous Areas furnish power to strain gage transducers, measure the return voltage, and adjust the 4-20 milli amp loop current to be proportional to the transducer signal.

The HI 2201LT is Factory Mutual approved and safe to use in hazardous operating environments. The **HI 2204LT IS NOT Factory Mutual approved** and should not be used in a hazardous environment.

The HI 2201LT/HI 2204LT can be used to transmit any strain gage signal with a bridge resistance of more than 88 ohms. This allows transmission of pressure, load, weight, force and torque signals including up to four 350 ohm, full bridge, load cells.

The HI 2201LT/HI 2204LT powers itself and the attached strain gage transducers from the 4-20 ma loop power. This allows sensitive strain gage signals to be transmitted over long distances without the expense of installing additional power to remote locations. A common, low-cost power supply can be placed anywhere in the 4-20 ma loop.

As the power supply provides loop power, the HI 2201LT/HI 2204LT controls the current flow (4-20 ma) representing the strain gage signal and receiving devices can be placed anywhere along the loop to monitor current flow. Typical receiving devices include:

- Chart Records
- Panel Meters
- Bar Graphs
- Programmable Controllers
- Computers
- Relay Set Point Modules

Most receiving devices may be characterized as a load resistor allowing the 4-20 ma signal to cause a proportional voltage drop across it. Multiple receivers may be placed on the loop provided the loop power supply can drive the combined loads. this can be calculated by adding the voltage requirements of the HI 2201LT/

## HI 2201LT/HI 2204LT

HI 2204LT (14 VDC) to that of each receiving device (loop resistance x 20 ma).

The Level Indicator applies power to each transducer in pulses a few milliseconds long at a rate of 90 pulses per second. The Level Indicator measures the voltage across the output terminals of the transducer with each power pulse, and it converts the average into a smooth current that varies with the transducer signal. This method of powering the transducer allows the Level Indicator to power up to four load cells. Though each load cell requires more than 4 ma excitation, the Level Indicator itself draws no more than 4 ma average current at zero weight load, and no more than 20 ma average current at full scale.

The Level Indicator is potted and sealed to withstand typical industrial environments. It is small enough to be mounted on a load cell summing board inside of a standard 5" x 7" x 3.5" NEMA 4 enclosure.

### Specifications

#### Physical Dimensions

Length: 4.50 Inches (114.3 mm)  
Width: 2.15 Inches (54.6 mm)  
Height: 1.30 Inches (33.02 mm)  
Weight: 8 oz. (.227 Kgs)

#### Power Requirement

Minimum: 15 VDC  
Maximum: 50 VDC  
Zero Scale: 4 ma  
Full Scale: 20 ma

#### Load Cell Excitation

5 V (pulsed), 90 hz

#### Zero Offset Range

Coarse: 2 mV/V  
fine: 0.04 mV/V

#### Sensitivity

3 mV/V (Continuously Adjustable from 2 mV/V to 3 mV/V)

#### Linearity

0.11% of full scale\*

\* Some barrier protection is required where the 2201 is located in a hazardous area.

**Operating Temperature Range** 0° C to +60° C (+32° F to +140° F)

**Temperature Coefficient** 0.025% per degree Celsius

**Signal Current Ripple** 20 mV p-p at 20 ma into 500 ohms

**Power Supply Rejection** 0.015% (max) 20 to 30 V  
0.10% (max) 15 to 50 V

**Approvals (HI 2201LT Only)** FM approved

**Approvals HI 2201LT & HI 2204LT** CE

**Installation**

The Loop Powered Level Weight Transmitter is usually installed close to the strain gage(s) to minimize the expense of special wiring, such as load cell cable. Wiring positions are indicated on the top surface next to each terminal strip.

**Junction Box with Strain Gage Summing Board (HI 2201LT-A3 or HI 2201LT-A5)**

The transmitter is available in a NEMA 4 junction box.(See Fig. 1)

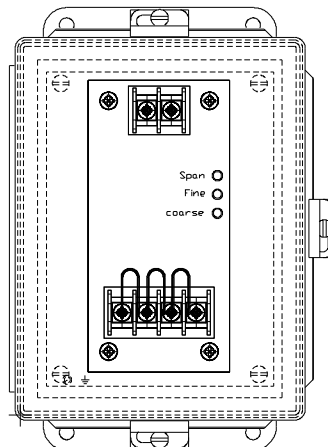

**FIG. 1 HI 2201LT/HI 2204 (-A3 OR -A5) IN NEMA 4 JUNCTION BOX/TOP VIEW**

The HI 2201/2204LT-A3 and HI 2201/2204LT-A5 Loop Powered Level Weight Transmitter comes mounted on a load cell summing board within a NEMA 4 junction box. The load cell summing board is designed to allow balancing pots to be installed if required. (See Fig. 2)

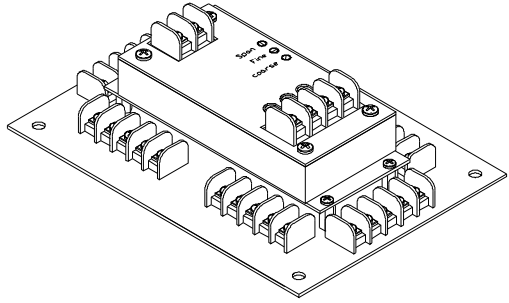

**FIG. 2 TRANSMITTER INSTALLED ON LOAD CELL SUMMING BOARD (-A3 OR -A5 OPTION)**

**Input - Strain Gage Transducer**

Strain Gage signals are typically very low in voltage causing them to be susceptible to noise. It is a good practice to isolate strain gage signals from high voltage (110 VAC) lines. It is highly recommended that the transducer signal wire be routed in its own conduit. The transducer cable should have a shield which can be earth grounded near the transmitter.

**Output/Power Loop**

The loop power connection provides power to the HI 2201LT/HI 2204LT and provides the 4-20 mA signal. The transmitter must have from 15 VDC to 50 VDC across its LOOP terminals at up to 20 mA (full scale output). since all devices in the output/power loop are in series minimum power supply voltage, at 20 mA, must equal the total voltage drop across all of the other devices in the loop, plus 15 VDC for the HI 2201LT.



The transmitter output loop can be wired with any two conductor shielded cable. The two inner conductors are connected to the output of the transmitter at the two terminals marked LOOP. (See Fig. 3 & 4)

Note which wire is connected to each terminal to maintain correct polarity within the loop.

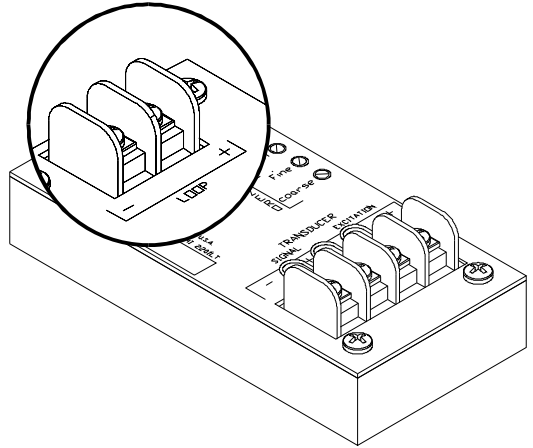

**FIG. 3 OUTPUT LOOP TERMINALS**

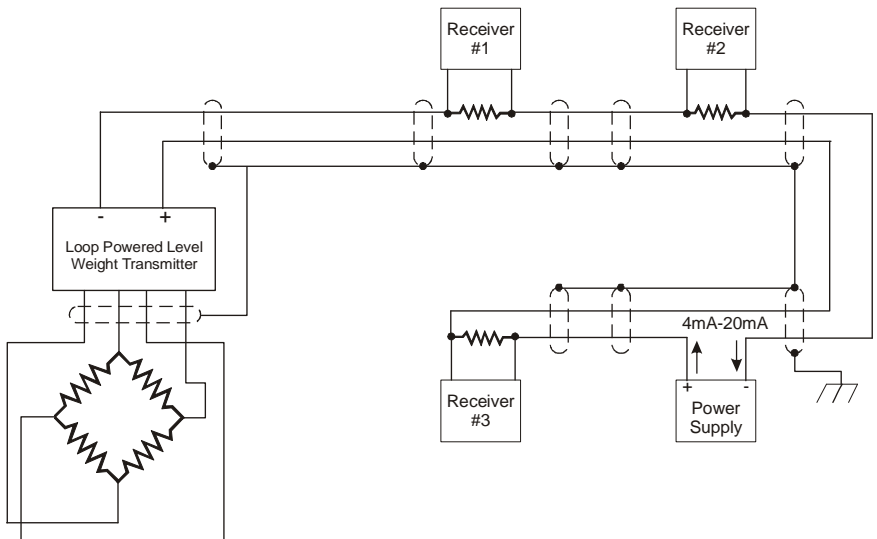

**FIG. 4 OUTPUT/POWER LOOP WIRING**

**NOTE:**

*Be sure to shield the tie point for CE compliance.*

**Earth Ground and Signal Return**

“Earth Ground” is used here to indicate a point actually connected to a path into the Earth’s ground. The term “signal return” is used to indicate a return path for signals to the negative side of the power supply, or in the case of the output/loop, signal return means the more negative side of the voltage being measured. (See Figs. 4 & 5)

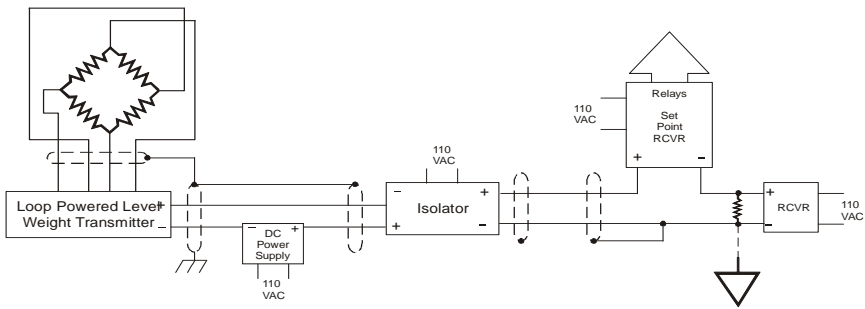

**FIG. 5 TYPICAL SYSTEM WIRING WITH ISOLATION**

**NOTE:**

*Be sure to shield the tie point for CE compliance.*

Receivers may be inserted into the minus or the plus power supply/transmitter path, or both. It is not necessary that one of the transmitter output leads be connected directly to ground.

Appropriate grounding and shielding helps to protect the signals from noise. However, it may be necessary to try various ground/shield configurations to find the best one for a particular installation. Figures 4 & 5 are examples only.

The transducer cable shield should be connected to either the earth ground or the signal return, on the input side of the transmitter to protect against noise, but not to both. The recommended configuration consists of the transducer cable shield connected to the output/power cable shield and to the signal return.

**Precautions on Grounding**

1. Do not connect the signal return to the earth ground at more than one point in the output/power loop.
2. Any receiver or electronic device inserted in the output/power loop must be designed so that the connections to the loop are isolated from ground.

**NOTE:**

*Only the one point where the loop is already grounded can accept a grounded lead.*

3. Do not connect the earth ground to the signal return in the transmitter input circuit.
4. Do not connect any of the transducer signal wires to the earth ground.

**Isolation**

The AC power sources for this instrument must be separate and isolated from the power supplied to any switches, relays, solenoids, or motors which can introduce excessive noise into the instrument's circuits.

Load cells and load cell signal wires are not typically grounded, and they are not typically connected to their shields or to the load cell case. If the recommendations given in the grounding and shielding section are followed, there will be no need for isolation in the transmitter/load-cell circuit. In fact, in the load cell circuit, isolation adds to the cost and inaccuracy and is not recommended.

It is generally not necessary to provide isolation in the output loop. However, when ground-loop problems do occur, a Loop isolator designed to handle the 4 ma to 20 ma Loop Powered Level Weight Transmitter signal may be installed. (See Fig. 5)

**Calibration**

The HI 2201LT Loop Powered Level Weight Transmitter is calibrated at the factory for 4 ma current output with zero millivolts input and 20 ma output for 15 mV input (based on a 3mV/V input source and 5 V excitation). In most cases, the transmitter will require a very simple recalibration to the system in which it is installed. The calibration procedure provided is designed to be used either in new installations or for recalibration of existing systems, and will work with 3 mV/V or 2 mV/V load cells. Be sure to read all cali-

brations instructions before attempting to calibrate the instrument.

## **Calibration Controls**

### **Coarse (Zero)**

The Coarse Control is used to remove large deadloads or offsets such as the weight of the scale's platform, container or any other constant weight on the load cells which is part of the weighing equipment itself. This control can subtract as much as 65% of full scale from the transmitter's output.

### **Fine (Zero)**

This control is a fine offset adjustment. Its range is sufficient to fine tune the COARSE adjustment.

### **Span**

The Span Control adjust the gain of the transmitter. It determines how many millivolts (of transducer signal) per volt (of transducer excitation) will be represented by the 4 ma to 20 ma output range.

The gain can be adjusted from 3 mV input per volt of excitation to as high as 0.8 mV input per volt of excitation. This broad range of sensitivity allows for the wide variation in transducer range that remains after deadload compensation is subtracted by the COARSE Zero adjustment.

## **Calibration Procedures**

The measuring instruments used in the following procedure must be designed so that test leads are isolated from ground. These are either "floating" and/or "isolated" and/or "differential" types.

Insertion of any measuring device, or voltage dropping resistor for a measuring device in the output/powers loop requires that the power supply voltage be high enough to supply the extra voltage (See Input-Strain Gage Transducer). The following is an example using load cells in a weighing application.

- Step 1. Remove any weight from the scale. Allow deadload to remain. If deadload is counterbalanced, also allow counterbalancing to remain.

- Step 2. Install a milli ammeter, in series, into the output/power loop of the transmitter. If a voltmeter is to be used for measurements, and a resistor for calibration is not already installed in the system, install a 100 ohm, +/- 0.1%, 1/4 W resistor, in series, into the output/power loop of the transmitter. Voltmeter readings are show in parentheses.
- Step 3. If a voltmeter is used, attach the voltmeter across the 100 ohm resistor.
- Step 4. Adjust the transmitter FINE control for a 4 ma (1/4 V) reading on the meter. If necessary, center the FINE control, and adjust COARSE control first.
- Step 5. Place a know weight on the scale. If possible, use a full scale weight for best results.
- Step 6. Adjust the SPAN for 20 ma (2V) for full-scale.
- Divide: Calibration Weight/Full-Scale  
Weight = (F)raction of full scale.
  - Multiply: (F) (16 ma) = 1, the current caused by the calibration weight.
  - Add: 1 + 4 ma = Calibration Current, 1c
  - Adjust the SPAN to produce the Calibration Current, 1c, in the output/power loop.

**Example**

Calibration Weight = 750 pounds  
Full Scale Capacity = 1000 pounds

Adjust SPAN for:

$$\begin{aligned}(750/1000) (16 \text{ ma}) + 4 \text{ ma} &= 1c \\(0.75) (16 \text{ ma}) + 4 \text{ ma} &= 1c \\12 \text{ ma} + 4 \text{ ma} &= 1c \\16 \text{ ma} &= 1c\end{aligned}$$

- Step 7. Remove the calibration weight and recheck that the zero reading is still 4 ma (0.4 V). Adjust the FINE control if necessary.
- Step 8. Place the calibration weight back on the scale and recheck that the calibration reading is still correct. Adjust the SPAN control if necessary.
- Step 9. Repeat steps 7 & 8 until no further adjustment is necessary to keep both measurements within the system tolerances.
- Step 10. Calibration is complete.

### **Trouble Shooting Procedures**

This section is intended to provide assistance in solving minor system problems.

#### **Malfunction: No Output**

Checks to be made:

1. Check voltage at + & - loop connections. You should get a reading of 15 VDC to 50 VDC.
2. Verify load cell connections.
3. Using an Oscilloscope, verify that you have a pulsed 5 VDC between terminals labeled - & + excitation.

#### **Malfunction: No Change in Input**

Checks to be made:

1. Load Cell signal output below original setting. If the signal level returned by the Load Cells is below the previous deadload setting, measure approximately 2.3 ma between the loop + & - terminals.
2. Load Cell signal output above original setting. If the signal level returned by the load cell is above the previous Span setting, measure approximately 23 ma between the loop + & - terminals.

#### **Malfunction: Output Drifts**

Checks to be made:

1. Verify load cell connections.
2. Verify Power Supply output and confirm that it is outputting a constant voltage.

**Factory Mutual (FM) Approval (HI 2201LT Only)**

The HI 2201LT is FM approved and intrinsically safe for Class I, II, III, Division I, Division II, Groups A,B,C,D,E,F and G hazardous locations in accordance with entity requirements and Hardy drawing No. 0582-0563.

The HI 2201LT is approved with the MTL 705 Barrier (See Fig. 6) or with any other FM-approved barrier provided that the maximum entity parameters are met. (See Fig. 7)

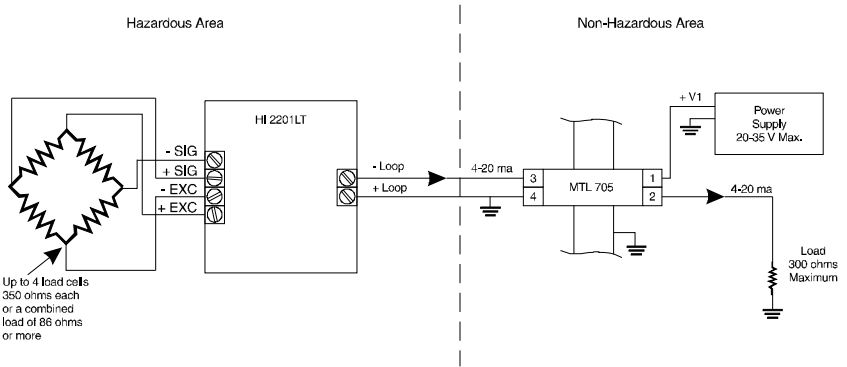

**FIG. 6 MTL705 BARRIER**

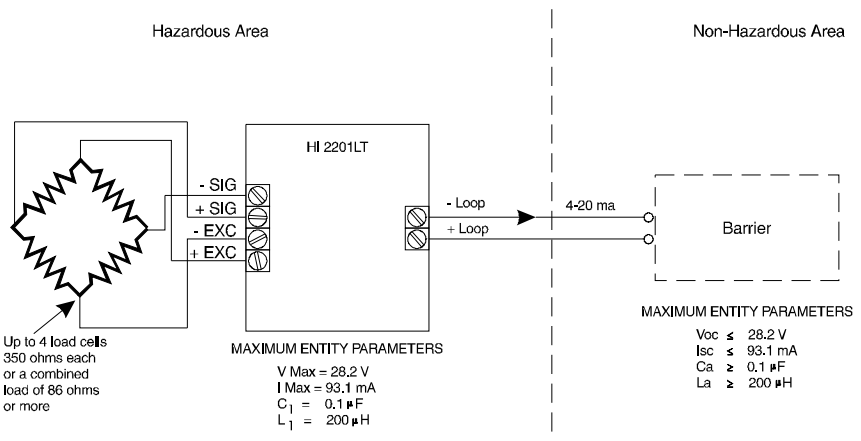

**FIG. 7 FM APPROVED BARRIER**

