

REV.	ECO/DDC	DESCRIPTION	DATE	DRAFT	CHECK	APV'D
A	05750	RELEASED FOR PRODUCTION REVISED PER DDC	4-22-98	L.P.	P.W.	T.K.
B	05666	REVISED PER ECN.	06-15-98	V.J.C.	L.B.O.	D.C.
C	06401	REVISED PER ECN.	1-25-99	R.B.	L.B.O.	H.T.
D	07369	REVISED PER ECN.	05-08-00	L.B.O.	V.J.C.	G.I.

0551-0435-01 PORTABLE DISPLAY OPTION
(INCLUDES DISPLAY AND CABLE)

6032-0015 CABLE

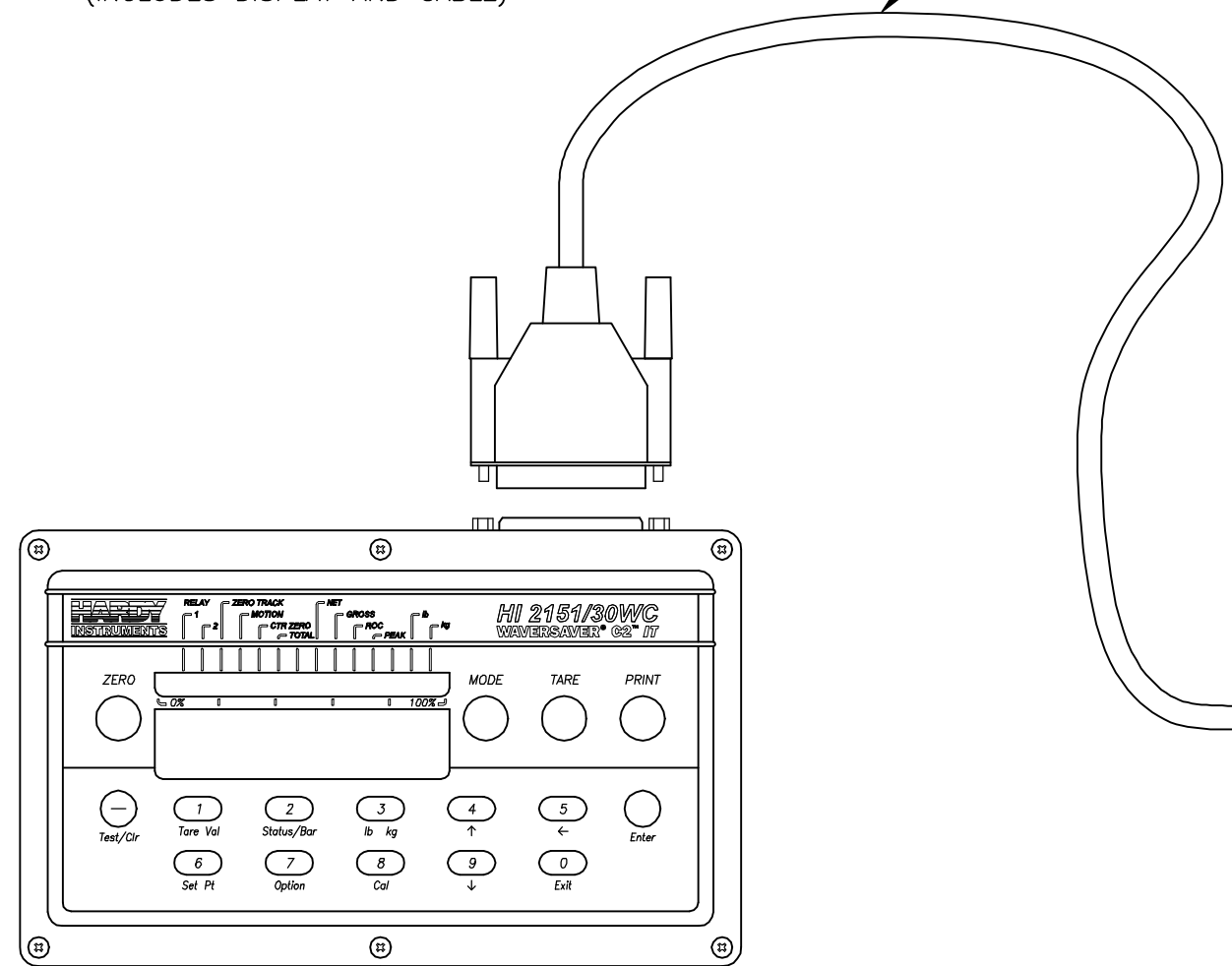

HI 2151/30WC BLIND REMOTE (-BR CONFIGURATION)

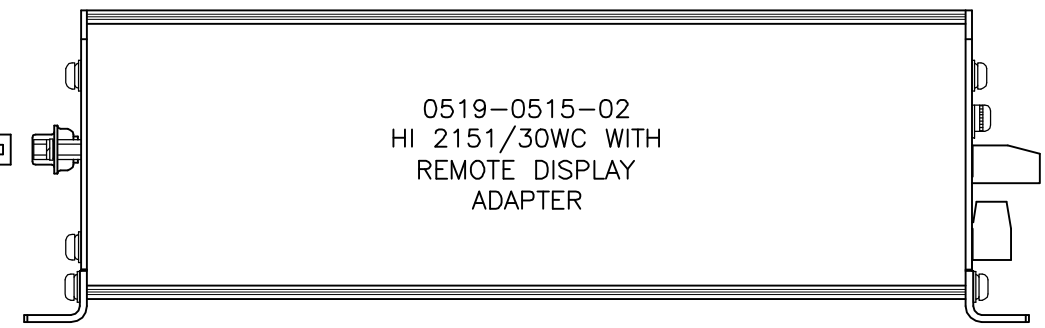

0519-0516-01 PORTABLE DISPLAY ASSY

- 5. MOUNT UNIT USING #6 OR M3.5 HARDWARE (NOT SUPPLIED WITH UNIT).
- 4. INTERCONNECT WIRING FOR UNITS INSTALLED IN HAZARDOUS LOCATIONS TO BE PER NATIONAL ELECTRIC CODE (ANSI/NFPA-70).
- 3. SEE SHEET 3 FOR CABLE TERMINATIONS.
- 2. SEE SHEET 2 FOR BLIND REMOTE UNIT MOUNTING DIMENSIONS.
- 1. SEE 0596-0224 FOR OPERATION AND INSTALLATION MANUAL.

NOTES: UNLESS OTHERWISE SPECIFIED

PROPRIETARY NOTICE
ALL DATA AND INFORMATION CONTAINED IN OR DISCLOSED BY THIS DOCUMENT IS CONFIDENTIAL AND PROPRIETARY INFORMATION OF HARDY INSTRUMENTS INC. AND ALL RIGHTS THEREIN ARE EXPRESSLY RESERVED. BY ACCEPTING THIS MATERIAL THE RECIPIENT AGREES THAT THIS MATERIAL AND THE INFORMATION CONTAINED THEREIN IS HELD IN CONFIDENCE AND IN TRUST AND SHALL NOT BE USED, COPIED, REPRODUCED IN WHOLE OR IN PART, NOR ITS CONTENTS REVEALED IN ANY MANNER TO OTHERS, EXCEPT TO MEET THE SPECIFIC PURPOSE FOR WHICH IT WAS DELIVERED.

ITEM	QTY	PART NUMBER	DESCRIPTION	COMMENTS
		0584-0028	I/I DIAGRAM, HI 2151/30WC-BR	
PARTS LIST				
UNLESS OTHERWISE SPECIFIED DIMENSIONS ARE IN INCHES AND [MM]. TOLERANCES ARE: FRACTIONS: N/A DECIMALS: .XX = ±.03 .XXX = ±.010 ANGLES: ±0°, 30'		CONTRACT NO.		HARDY INSTRUMENTS I/I DIAGRAM, HI 2151/30WC-BR
		APPROVALS		
MATERIAL		DRAWN V. CHULA	DATE 10-06-97	
FINISH		CHECKED P. WYLIE	DATE 10-08-97	
DO NOT SCALE DRAWING		APPROVED D. BOYDEN	DATE 10-10-97	
		ISSUED K. McNULTY	DATE 10-14-97	SIZE D
		PRODUCTION	DATE	FSCM 21316
				DRAWING NO. 0584-0028
				REV. D
				FILE NAME: 584028D1.DWG
				SCALE: NONE
				SHEET 1 OF 4

HI 2151/30WC BLIND REMOTE (-BR CONFIGURATION)

Ø.15[3.81] X .11[5.59] L SLOT
4 PL

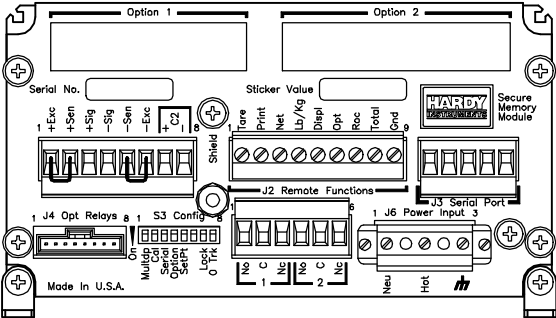
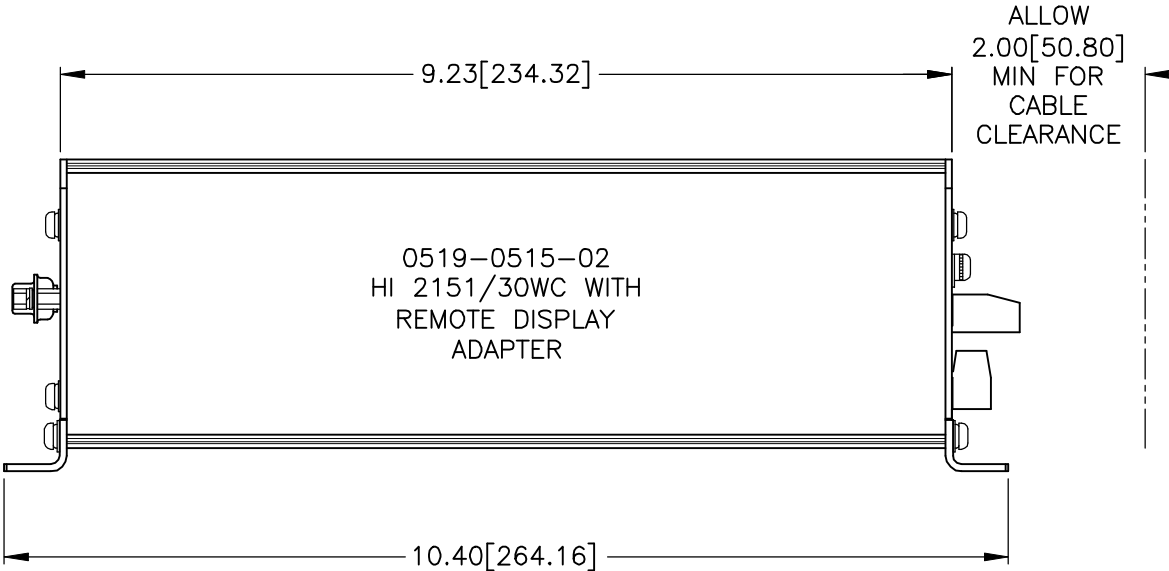
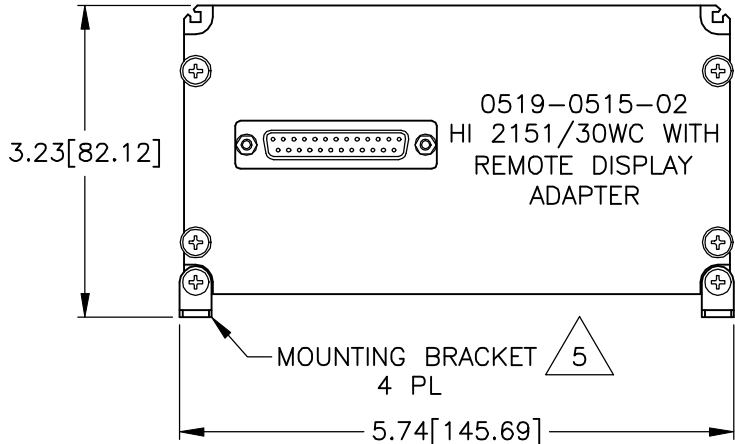
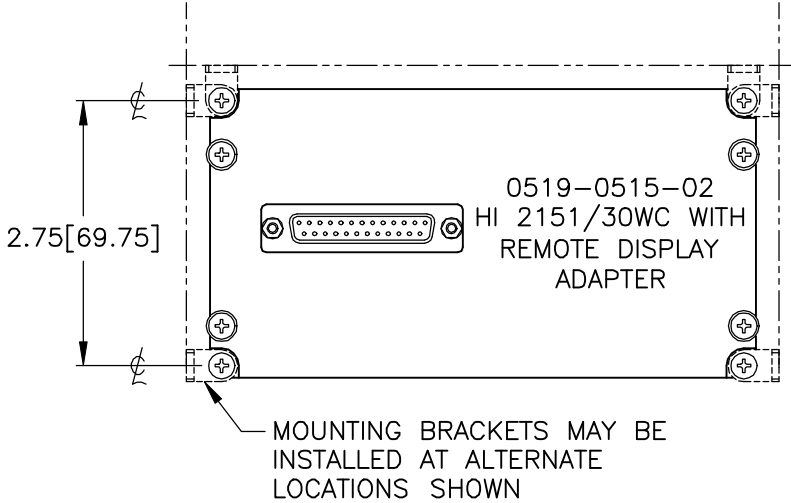
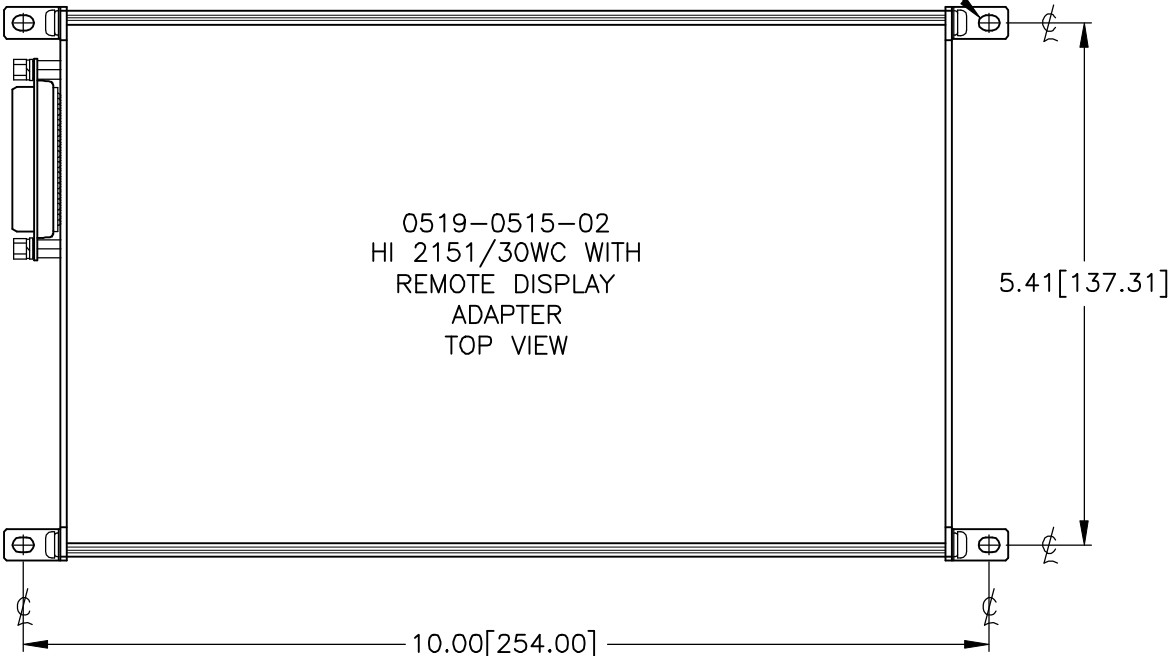

HARDY INSTRUMENTS			
TITLE I/I DIAGRAM, HI 2151/30WC-BR			
SIZE D	FSCM 21316	DRAWING NO. 0584-0028	REV. D
FILE NAME: 584028D1.DWG		SCALE: NONE	SHEET 2 OF 4

J6 Power Input

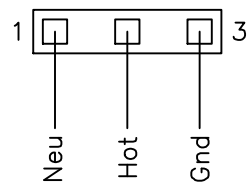

WIRE SIZE: 26 AWG MIN / 14 AWG MAX

NOTES:

- DO NOT RUN LOAD CELL CABLE PARALLEL TO, OR IN SAME CONDUIT WITH, POWER WIRING, RELAY CABLE OR OTHER HIGH ENERGY CABLES.
- FACTORY INSTALLED JUMPERS TO REMAIN IN PLACE FOR FOUR WIRE LOAD CELL CONNECTION. JUMPERS TO BE REMOVED FOR SIX WIRE OR EIGHT WIRE (C2) LOAD CELL CONNECTIONS. EXCITATION AND SENSE WIRES TO BE CONNECTED TOGETHER IN JUNCTION BOX.
- REQUIRED LOAD CELL CABLE FOR C2 SECOND GENERATION CALIBRATION SYSTEM: HARDY INSTRUMENTS P/N 6020-0001.
- SEE 0596-0224 OPERATION AND INSTALLATION MANUAL FOR ADDITIONAL INFORMATION ON LOAD CELL CONNECTIONS.

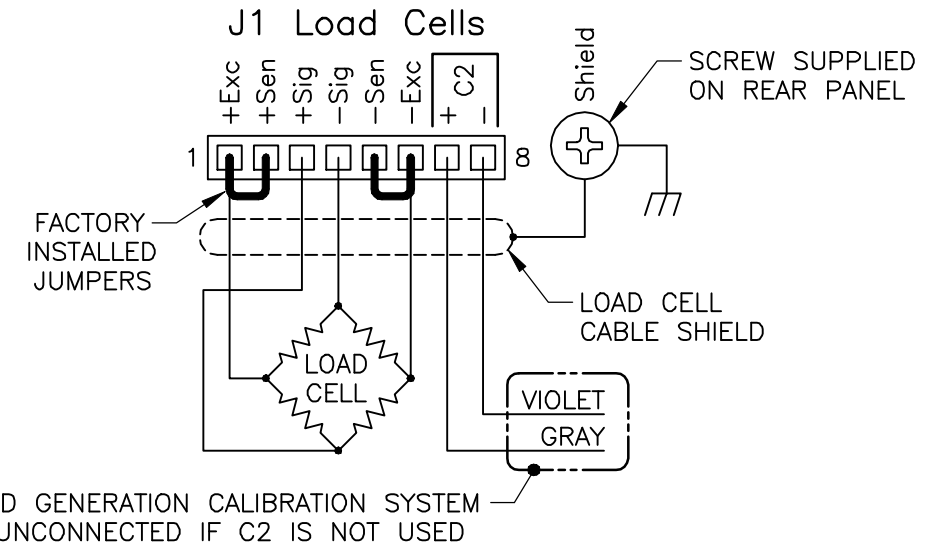

TERMINALS FOR C2 SECOND GENERATION CALIBRATION SYSTEM LEAVE THESE TERMINALS UNCONNECTED IF C2 IS NOT USED

J2 Remote Functions

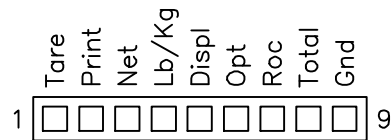

NOTES:

- MOMENTARY FUNCTIONS REQUIRE 100 mSEC OR GREATER TO GND FOR PROPER ACTIVATION, ONLY USE REMOTE FUNCTIONS GROUND (J2 PIN 9) FOR ACTIVATING REMOTE FUNCTION.
- REMOTE FUNCTIONS ARE NOT ISOLATED. DO NOT BUNDLE WIRING FROM REMOTE FUNCTIONS WITH POWER WIRING, RELAY CABLE OR ANY OTHER HIGH ENERGY CABLES.
- WIRE SIZE: 22 AWG MIN / 12 AWG MAX.

J5 Relays

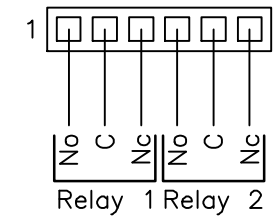

NOTES:

- RELAY CONTACT RATING: 3 AMPS @ 125 VAC MAX
1.5 AMPS @ 250 VAC MAX
NON-FUSED
- WIRE SIZE: 22 AWG MIN / 12 AWG MAX.

J3 Serial Port Connections

NOTES:

- CUSTOMER TO SELECT DESIRED SERIAL PORT INTERFACE OPTION WHEN ORDERING UNIT.
- DIAGRAMS SHOWN DEPICT FACTORY DEFAULT S1 DIP SWITCH SETTINGS ONLY. REFER TO 0596-0224 OPERATION AND INSTALLATION MANUAL FOR DIP SWITCH SETTINGS CONCERNING SPECIFIC SERIAL PORT INTERFACE APPLICATIONS.
- MAIN CONTROLLER PWB LOCATED INSIDE UNIT. REFER TO 0596-0224 OPERATION AND INSTALLATION MANUAL FOR ACCESS TO S1 DIP SWITCH AND JP1 JUMPER BLOCK.
- WIRE SIZE: 22 AWG MIN / 12 AWG MAX.

RS-232C (A1 OPTION)

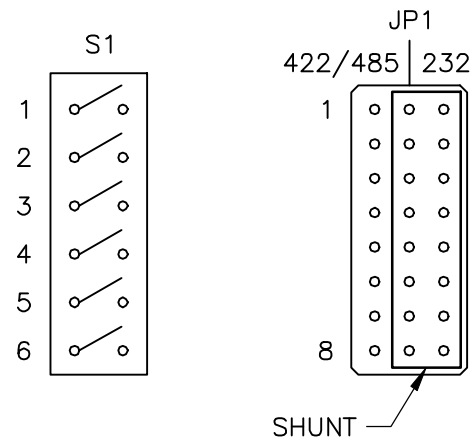
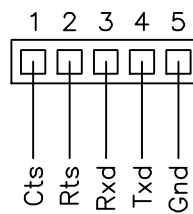

MAIN CONTROLLER PWB DIP SWITCH AND JUMPER BLOCK CONFIGURATION

EIA 422 (A2 OPTION)

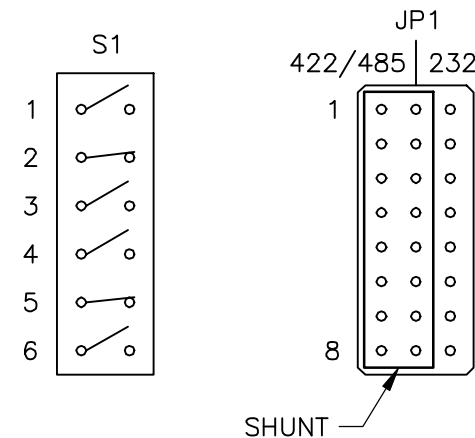
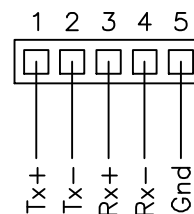

MAIN CONTROLLER PWB DIP SWITCH AND JUMPER BLOCK CONFIGURATION

EIA 485 (A3 OPTION)

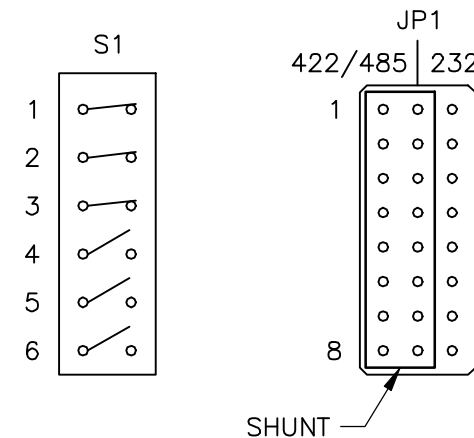
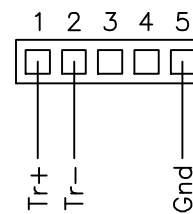

MAIN CONTROLLER PWB DIP SWITCH AND JUMPER BLOCK CONFIGURATION

**HARDY
INSTRUMENTS**

TITLE
I/I DIAGRAM,
HI 2151/30WC-BR

SIZE	FSCM	DRAWING NO.	REV.
D	21316	0584-0028	D
FILE NAME: 584028D1.DWG		SCALE: NONE	SHEET 3 OF 4

REMOTE I/O INTERFACE FOR ALLEN-BRADLEY NETWORK OPTION

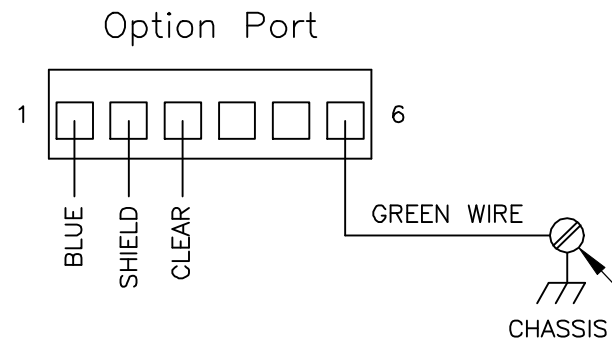

WIRE: 78 OHM SHIELDED TWISTED PAIR TWINAX CABLE (20 AWG)

CABLE DIAMETER RANGE:
.157[3.998] - .315[8.000]

BAUD	JUMPER
57.6 AND 115.2K	W1
230.4K	W2

* STANDARD CONFIGURATION: 57.6 AND 115.2K BAUD
NOTE: FOR MORE INFORMATION, REFER TO 0596-0173 OPERATION AND INSTALLATION MANUAL.

LUG ON GREEN WIRE MUST BE ATTACHED TO INSTRUMENT PANEL. GREEN WIRE AND LUG SUPPLIED BY HARDY INSTRUMENTS

150 OHM @ 57.6K BAUD	10,000 FT (3048 M)
150 OHM @ 115.2K BAUD	5,000 FT (1524 M)
82 OHM @ 230.4K BAUD	2,500 FT (762 M)

NOTE: FOR MORE INFORMATION, REFER TO 0596-0173 OPERATION AND INSTALLATION MANUAL.

ANALOG OUTPUT OPTION

Option Port

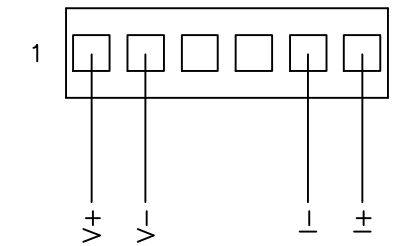

WIRE SIZE:
12 AWG - 22 AWG

CURRENT SELECTION		VOLTAGE SELECTION	
CONFIGURATION	JUMPER	CONFIGURATION	JUMPER
0 - 20mA	W1	0 - 5 VDC	W3
4 - 20mA	W2	0 - 10 VDC	W4

* STANDARD CONFIGURATION: 4 - 20mA, 0 - 10 VDC

NOTE: FOR MORE INFORMATION, REFER TO 0596-0224 OPERATION AND INSTALLATION MANUAL.

BCD OPTION

Option Port 2 Only

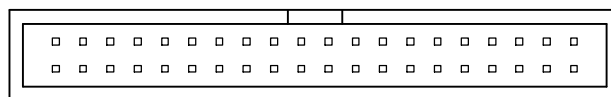

WIRING: 40 POSITION RIBBON CABLE (SUPPLIED BY HARDY INSTRUMENTS)

PRINT POLARITY SELECT	PRINT	W1
	PRINT	W2

* STANDARD CONFIGURATION: PRINT

NOTE: FOR MORE INFORMATION, REFER TO 0596-0224 OPERATION AND INSTALLATION MANUAL.

PROFIBUS OPTION

Option Port

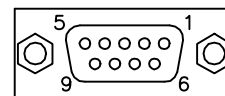

1	NC
2	NC
3	RXD/TXD-P
4	CNTR-P
5	GND
6	+5V
7	NC
8	RXD/TXD-N
9	NC

NOTE: FOR MORE INFORMATION, REFER TO 0596-0231-01 OPERATION AND INSTALLATION MANUAL.

TTL OUTPUT OPTION

(Used To Drive Optional Relays)

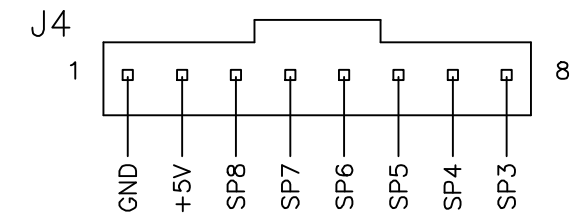

TTL OUTPUTS: 300mA PER LINE (NON-FUSED)
WIRING: CABLE SUPPLIED BY HARDY INSTRUMENTS

HARDY INSTRUMENTS			
TITLE I/I DIAGRAM HI 2151/30WC-BR			
SIZE D	FSCM 21316	DRAWING NO. 0584-0028	REV. D
FILE NAME: 584028D1.DWG		SCALE: NONE	SHEET 4 OF 4