

**Any-Weigh™
BENCH SCALES**

**OPERATION AND INSTALLATION
MANUAL**



Corporate Headquarters

9440 Carroll Park Drive, Suite 150

San Diego, CA 92121

Phone: (858) 278-2900

FAX: (858) 278-6700

Web-Site: <http://www.hardyinst.com>

Hardy Instruments Document Number: 0596-0268-01 Rev F

Copyright December 2002 Hardy Instruments, Inc. All Rights Reserved. Printed in the U.S.A. (941028)

CAUTION:

UNPACK WITH CARE

WHEN UNPACKING, DO NOT DISCARD THE PACKING CASE OR ANY PACKING MATERIAL, UNTIL THE CONTENTS OF THE PACKING CASE ARE INSPECTED AND CAREFULLY COMPARED WITH THE SHIPPING DOCUMENTS.

IF ANYTHING IS UNSATISFACTORY, PLEASE NOTIFY HARDY INSTRUMENTS IMMEDIATELY BY CALLING, FAXING OR E-MAILING TO:

Hardy Service Center
HARDY INSTRUMENTS, INC.
3860 Calle Fortunada
San Diego, California 92123-1825

Phone: (800) 821-5831
(858) 278-2900
FAX:(858) 278-6700

E-mail: hardysupport@hardyinst.com
Web Address: www.hardyinst.com

TO RETURN DEFECTIVE OR DAMAGED PRODUCT(S) CALL HARDY TECHNICAL SUPPORT FOR A HARDY SERVICE TICKET NUMBER (HST#). YOUR COMPANY NAME, ADDRESS, TELEPHONE NUMBER, SERIAL NUMBER OF THE UNIT AND A BRIEF DESCRIPTION OF THE PROBLEM SHOULD BE READY WHEN CALLING. FOR ALL NON-WARRANTY REPAIRS A PURCHASE ORDER OR CREDIT CARD IS ALSO REQUIRED.

IN CASE OF DAMAGE DUE TO SHIPPING, NOTIFY THE DELIVERING CARRIER IMMEDIATELY FOR AN INSPECTION.

Table of Contents

Chapter 1 - overview	-1-1
Introduction	-1-1
Description	-1-1
The Stainless Steel Top Cover	-1-1
Lower Frame Assembly	-1-1
Universal Scale Interface	-1-1
DeviceNet™ Scale	-1-2
Analog Scale	-1-2
Chapter 2 - specifications	-2-1
Electrical Specifications	-2-1
Universal Scale Specifications	-2-1
DeviceNet Scale Specifications	-2-2
Analog Scale Specifications	-2-2
Mechanical Dimensions	-2-3
Chapter 3 - installation	-3-1
Preinstallation Precautions	-3-1
Unpacking	-3-1
Leveling the Scale	-3-1
Universal Scale Electrical Connections	-3-3
DeviceNet Scale: Connecting to a DeviceNet Network	-3-4
DeviceNet Connection Wiring Diagram	-3-4
Analog Scale	-3-5
Chapter 4 - configuration	-4-1
SCOPE 4-1	
DeviceNet Communication Configuration	4-1
DIP Switch (S1) Configuration	-4-1
DIP Switch Location	-4-1
Accessing the DIP Switch	-4-2
Configuring the Baud Rate	-4-2
Configuring the DeviceNet Node Address	-4-2
Chapter 5 - Setup	-5-1
SCOPE	-5-1
Saving to Non-Volatile Ram	-5-1
Parameters	-5-1
Command Interface	-5-4
Format of Commands (4 byte input data)	-5-4
Examples Using the Command Interface	-5-5

Any-Weigh™ Series Bench Scales

Chapter 6 - calibration - - - - - **-6-1**
Calibration of the DeviceNet, Analog and Universal Bench Scales - - -6-1
C2 Second Generation Calibration - - - - - -6-1
Test Weight Calibration (Hard Cal) - - - - - -6-1
Material Substitution - - - - - -6-1
Universal Scales HI SBU Series - - - - - -6-1
DeviceNet Scales HI SBD Series - - - - - -6-1
THE BUTTON® - - - - - -6-2
C2® Calibration from RS NetWorx® - - - - - -6-2
Test Weight Calibration from RS NetWorx® - - - - - -6-3
Analog Scales HI SBA Series - - - - - -6-4
 Calibration Controls - - - - - -6-4
 Coarse (ZERO) - - - - - -6-4
 Fine (ZERO) - - - - - -6-4
 Span - - - - - -6-4
 Calibration Procedures - - - - - -6-5

Chapter 7 - OPERATION - - - - - **-7-1**
Scope - - - - - -7-1
Operating Capabilities - - - - - -7-1
DeviceNet Scale - - - - - -7-1
 Explicit Message Request Parameters - - - - - -7-1
 Monitoring Weight Readings from RS NetWorx - - - - - -7-2
 Network Status (DS1) - - - - - -7-2
 Scale Status (DS2) - - - - - -7-2
Analog Scale - - - - - -7-3

Chapter 8 - Troubleshooting 8-1
Scope - - - - - -8-1
Problem: - - - - - -8-1
 Scale Does Not Respond When Weight is Applied - - - - - -8-1
 Scale Indication is not linear - - - - - -8-1
 Scale Reads Backwards - - - - - -8-1
 Scale Reading drifts or is Erratic - - - - - -8-1
 DeviceNet Scale: Module LED does not Come Back on
 When Performing Calibration with The Button - - - - - -8-2
 DeviceNet Scale: Module LED is Flashing Red - - - - - -8-2
 Analog Scale: Malfunction, No Output - - - - - -8-2
 Analog Scale: No Change in Input - - - - - -8-2
 Analog Scale: Output Drifts - - - - - -8-2
Service and Repair (All Models) - - - - - -8-2

Index - - - - - **-1-1**

Table of Illustrations

CHAPTER 2 - SPECIFICATIONS- - - - -2-1

FIG. 2-1 A DIMENSION- - - - -2-3

FIG. 2-2 B DIMENSION- - - - -2-3

CHAPTER 3 - INSTALLATION - - - - -3-1

FIG. 3-1 LEVELING CORNERS- - - - -3-2

FIG. 3-2 LEVELING FEET - - - - -3-2

FIG. 3-3 LEVELING SCALE- - - - -3-3

FIG. 3-4 DEVICENET CONNECTOR - - - - -3-4

FIG. 3-5 VIEWED FROM THE WIRE PIN SIDE - - - - -3-5

FIG. 3-6 VIEWED FROM THE SOCKET SIDE- - - - -3-5

FIG. 3-7 ANALOG SCALE/OUTPUT/POWER LOOP WIRING - - - -3-6

CHAPTER 4 - CONFIGURATION- - - - -4-1

FIG. 4-1 DIP SWITCH LOCATION/BOTTOM VIEW - - - - -4-1

FIG. 4-2 FACTORY DEFAULT DIP SWITCH CONFIGURATION- - -4-2

CHAPTER 6 - CALIBRATION - - - - -6-1

FIG. 6-1 THE BUTTON LOCATION/BOTTOM VIEW- - - - -6-2

Any-Weigh™ Series Bench Scales

CHAPTER 1 - OVERVIEW

Introduction

Congratulations on your purchase of a Hardy Instruments Any-Weigh™ Bench Scales. Behind your purchase is over eighty years of quality, reliability and technical innovation.

The Hardy Any-Weigh™ Bench Scales are designed for table top or floor applications requiring high accuracy and reliability. The covers are all stainless steel for durability. The bases have no bearings, spirit levels, or moving parts that can be damaged or wear out. The active element of the scale are precision strain gauge load sensors.

NOTE:

Any-Weigh™ is a trademark of Hardy Instruments Incorporated.

Description

The basic Any-Weigh Bench Scale consists of three major components:

1. Stainless Steel Top Cover.
2. Lower Frame Assembly with Four Load Cells
3. Four Leveling feet.

The Stainless Steel Top Cover

The top cover is a single piece constructed of series 300 Stainless Steel. The cover provides a weighing surface and offers protection to the load cells and electronics.

Lower Frame Assembly

The lower frame comes equipped with four leveling feet, four load cells, a shock load and corner overload protection. The lower frame is made of coated mild steel.

Universal Scale Interface

Directly attach the scale's 15 foot cable to any weighing instrument or controller. If interfacing with a Hardy Controller, you can take full advantage of WEVERSAVER® and C2® Electronic Calibration.

NOTE:

WEVERSAVER® and C2® are registered trademarks of Hardy Instruments Incorporated.

Any-Weigh™ Series Bench Scales

DeviceNet™ Scale

With DeviceNet™ you can use the scale to provide a weight output to any point on a DeviceNet™ Network. This version also incorporates both the WEVERSAVER® and C2® technologies. The DeviceNet™ Scale comes with a fifteen inch minimum length pig-tail connector.

NOTE:

DeviceNet™ is a trademark of the Open DeviceNet Vendor Association.

Analog Scale

The Analog Scale provides a 4-20mA output directly proportional to the weight reading. This version offers a low-cost, solution for bringing analog weight readings directly into a control system. The Analog Scale requires minimal additional wiring or hardware and comes with a 15 foot shielded 2 wire cable.

CHAPTER 2 - SPECIFICATIONS

Electrical Specifications

Universal Scale Specifications

Rated Output	0.900 ± 0.009 mV/V
Creep	0.030% R.O.
Excitation:	
Recommended	5-10 Volts AC or DC
Maximum	15 Volts AC or DC.
Total Error	0.03% of rated output full scale
Input Resistance	297.5 ± 10% ohm
Output Resistance	250 ± 5% ohm
Safe Load Limit	
At the Center Loading Point	300% Emax
Maximum Overload	
At the Center Loading Point	400% Emax
Temperature Range	
Operating	-10 to +65° C
Compensated	-10 to +40° C
Temperature Effect	
Output	0.0015% R.O./°F
Sensitivity	0.0008% R.O./°F
Cable	15 Feet, 8 conductor, Polyurethane Jacket, Floating Shield

Any-Weigh™ Series Bench Scales

DeviceNet Scale Specifications

Resolution	20 bit
Update Rate	10 or 55 per second
Averages	0-255 selectable
Combined Error	0.0315% of full scale
Temperature Coefficient	< 0.0005%/°C
Temperature Range	-10 to +50° C
Cable	15" inches minimum with male connector
Input Power	From DeviceNet Cable: 24 VDC ± 1% 179 ma Network/ 11-25VDC Node
Type	Generic
I/O Slave Messaging	Polling
Baud Rates	125K, 250K, 500K
Inputs	Gross, Net, Tare
Outputs	Weight - Metric/English, Zero & Tare, WAWERSAVER®, Calibration Type, Span Weight (Hard Cal), Cal Low Value, Cal High Value, Number of C2 Sensors (C2 Cal), Number of Averages

Analog Scale Specifications

Loop Power	15-50 VDC Across Scale V+ Black V - White
------------	---

NOTE:

A 15 VDC minimum would be with 0 ohm load; add 20 mV/ohm to the minimum loop voltage. A 500 ohm load would require 25 VDC minimum loop voltage.

Linearity* 0.11% of full scale

* Some barrier protection is required where the unit is located in a hazardous area.

Response Time 250 milliseconds

Sensitivity 3 mV/V of full scale with adjustment to 2 mV/V

Temperature Range 0 to +60° C

Temperature Coefficient 10.025%/° C

Cable 15 Feet

Mechanical Dimensions

The following dimensions are for reference only:

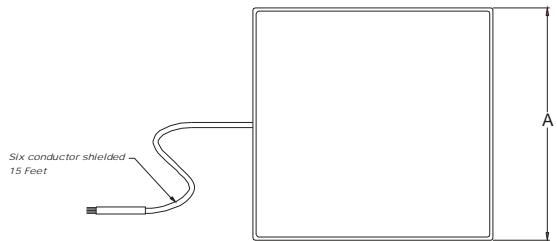

FIG. 2-1 A DIMENSION

NOTE:

Cable dimension is for the Universal and Analog scales only. DeviceNet cable length is different, see DeviceNet Specification above.

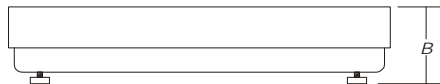

FIG. 2-2 B DIMENSION

Any-Weigh™ Series Bench Scales

	A	CAPACITY LB (KG)					
Model	Size In. (mm)	33 (15)	66 (30)	130 (60)	330 (150)	660 (300)	1300 (590)
HI 1212SBU/D/A	12x12 (298x298)	X	X	X			
HI 2424SBU/D/A	24x24 (600x600)			X	X	X	X
HEIGHT (B) in (mm)							
HI 1212SBU/D/A		1.54 (39.1)	1.56 (39.6)	1.75 (44.4)			
HI 2424SBU/D/A				1.78 (45.2)	1.68 (42.7)	1.87 (47.5)	2.05 (52.1)

Table 2-1: DIMENSIONS

CHAPTER 3 - INSTALLATION

Preinstallation Precautions

Do not store or operate the scale out of its specified temperature range. (See Temperature Ranges in Chapter 2)

Do not store other equipment on the scale when it is not in use or in storage.

Do not allow a build-up of debris on, around or under the scale.

Do not set the scale in water or allow water to settle around the scale. Provide Proper drainage.

Do not let moisture get on or into any of the electrical interconnections.

Do not allow static or other electrical discharges through the scale.

Do not try to remove the top plate.

Do not try to repair the scale. Contact Hardy Instruments Technical Support Department for any and all repairs.

Unpacking

The Any-Weigh Bench scales are shipped fully assembled and only require adjustment of the leveling feet. If there is any damage to the shipping container or to the scale, save all the packaging material and file a report with the shipper.

Leveling the Scale

- Step 1. Place the spirit level across each corner and adjust if necessary to level the corners. (See Fig. 3-1)

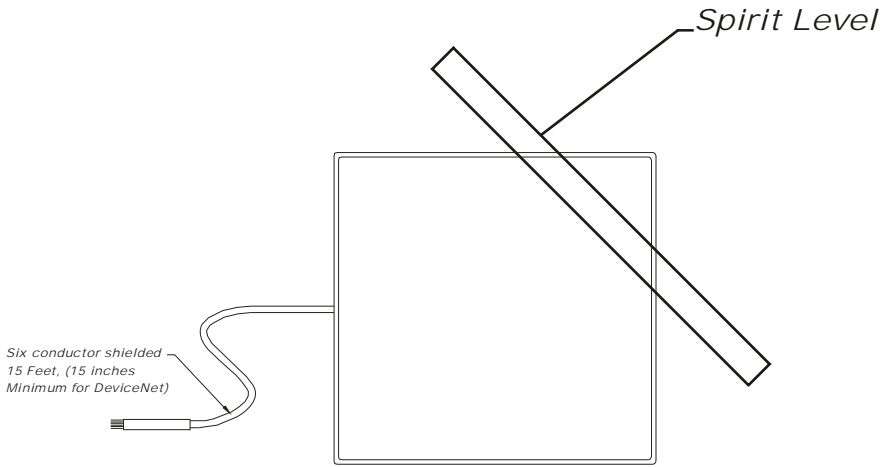

FIG. 3-1 LEVELING CORNERS

- Step 2. To level the platform, turn the leveling feet clockwise to lower the scale corner, or counter clockwise to raise it until you get a level reading. (See Fig. 3-2)

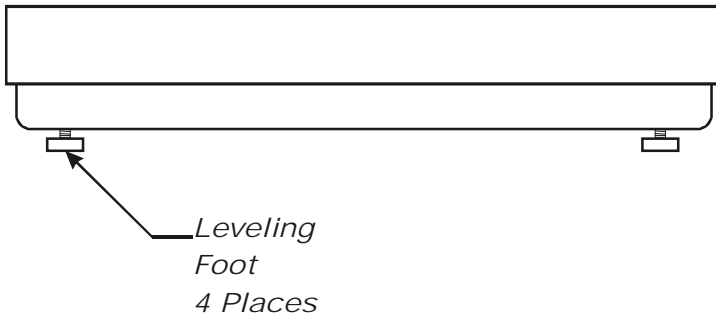

FIG. 3-2 LEVELING FEET

- Step 3. Place a spirit level across the center of the bench scale. Check for level and adjust the leveling feet if necessary. (See Fig. 3-3)

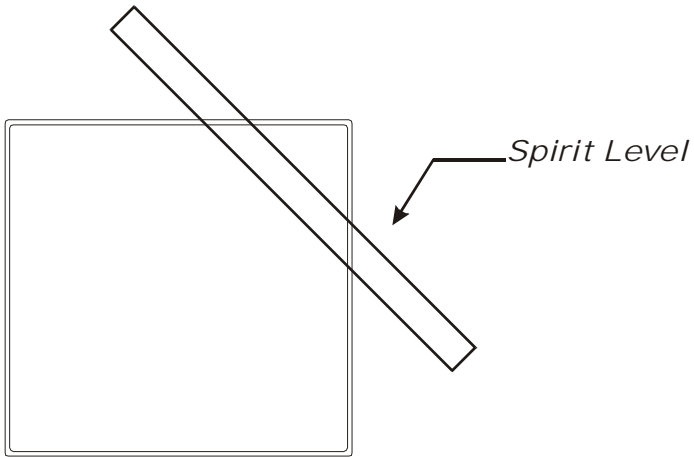

FIG. 3-3 LEVELING SCALE

Step 4. Rotate the spirit level 90° and check for level again.

Step 5. Adjust the leveling feet if necessary.

**Universal Scale
Electrical Connections**

Make sure the cable is not pinched and is clear of the feet. The Bench Scale requires a recommended DC or AC excitation voltage of 5 volts with a maximum of 15 volts. Wire the Scale cable to an instrument or indicator following the color code label found on the upper frame or as follows:

+ Excitation	Red
+ Sense	Blue
+ Signal	Green
+ C2 Cal	Gray
- Signal	White
- Sense	Brown
- Excitation	Black
- C2 Cal	Violet

WARNING

USE CAUTION WHEN WIRING. MAKE SURE TO DISCONNECT ALL POWER TO THE SCALE. FAILURE TO REMOVE POWER CAN RESULT IN SCALE OR INSTRUMENT DAM-

AGE, DEGRADATION OF PERFORMANCE OR PERSONAL INJURY

**DeviceNet Scale:
Connecting to a
DeviceNet
Network**

Plug the connector provided with the DeviceNet Scale to a connector on the DeviceNet Network Cable. (See Fig. 3-4)

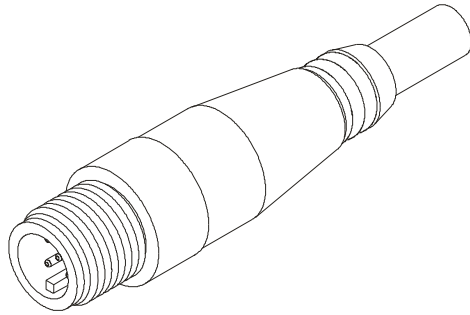

FIG. 3-4 DEVICENET CONNECTOR

**DeviceNet
Connection
Wiring
Diagram**

The AnyWeigh Bench scales are supplied with a short cable pig tail with a (male) Micro DeviceNet Connector (See Figs. 3-5 & 3-6). The DeviceNet Pin Out Diagram for the connector is as follows:

Pin #	Description	Color Code
1	Drain	BARE
2	V+	RED
3	V-	BLACK
4	CAN_H	WHITE
5	CAN_L	BLUE

Table 4-1: DeviceNet Wiring Diagram

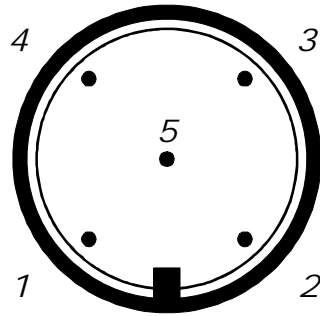

FIG. 3-5 VIEWED FROM THE WIRE PIN SIDE

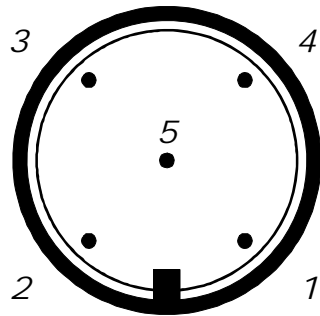

FIG. 3-6 VIEWED FROM THE SOCKET SIDE

NOTE:

You should also have an installation drawing that came with the bench scale (Drawing # 0588-0097) which also has the wiring diagram described.

Analog Scale

The fifteen-foot, 2 wire shielded cable provides power to the Analog Scale and transmits the 4-20 mA weight signal. The scale must have from 15 VDC to 50 VDC across its two loop wires at up to 20 mA (Full Scale Output). Since all devices in the output/power loop are in series, the minimum power supply voltage, 20 mA, must equal the total voltage drop across all of the other devices in the loop plus 15 VDC for the ANY-WEIGH Analog Scale.

Any-Weigh™ Series Bench Scales

Carefully note which wire is connected in the loop to maintain correct polarity within the loop. To reduce the change of ground loops do not connect any of the scales signal wires to earth ground. (See Fig. 3-7)

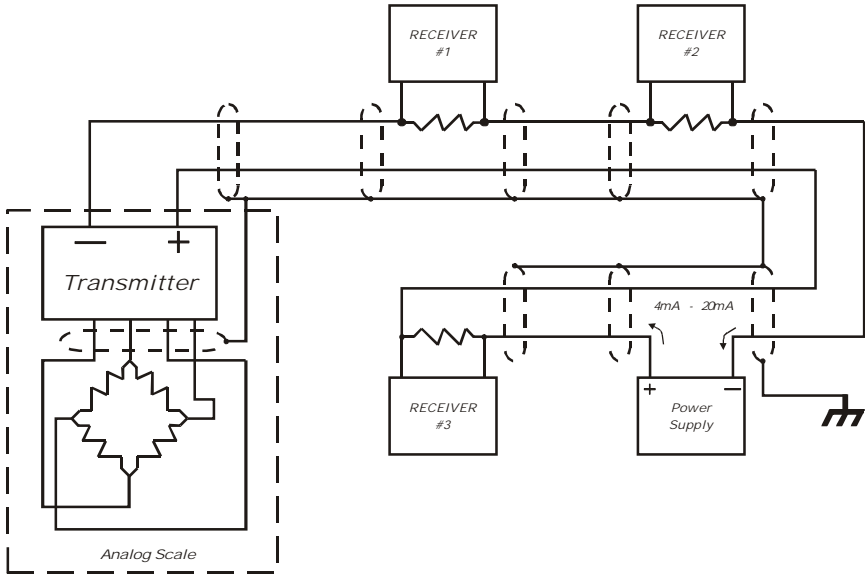

FIG. 3-7 ANALOG SCALE/OUTPUT/POWER LOOP WIRING

CHAPTER 4 - CONFIGURATION

SCOPE

The Universal Scale and the Analog Scale do not require any configuration. The DeviceNet scale configuration consists of setting the baud rate and node address on a DIP switch which is accessible through an access port on the bottom of the scale.

DeviceNet Communication Configuration

NOTE:

Be sure to configure the DeviceNet Scale before placing any vessels or containers on the scale.

DIP Switch (S1) Configuration

Configuring the DIP switch sets the following:

1. Baud Rate
2. Node Address

DIP Switch Location

The DIP Switch is located through an access port on the bottom of the scale. (See Fig. 4-1)

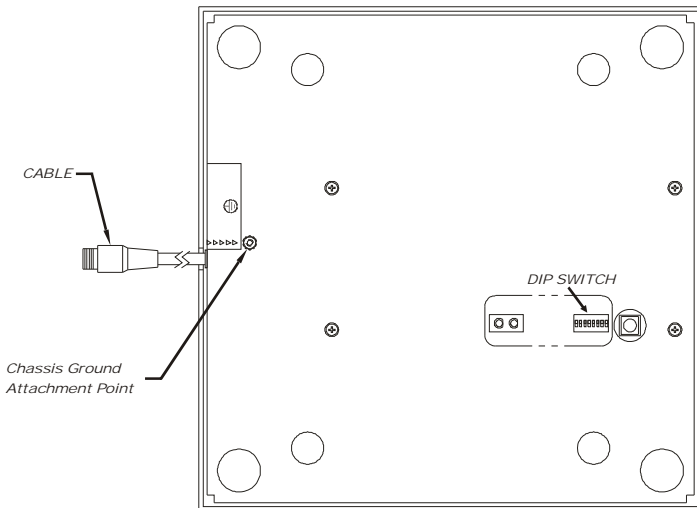

FIG. 4-1 DIP SWITCH LOCATION/BOTTOM VIEW

Any-Weigh™ Series Bench Scales

Accessing the DIP Switch

Tilt the scale up until you can reach the DIP Switch access port or if it is more convenient turn the scale upside down so that bottom is facing up to reach the DIP Switch access port.

NOTE:

Scale must be connected to earth ground from the Chassis Ground Attachment Point. (See Fig. 4-1)

Configuring the Baud Rate

Refer to Table 4-1 to configure the baud rate. 0 = OFF, 1 = ON (* is the default setting)

Baud Rate	S1-7	S1-8
125 kbps*	OFF	OFF
250 kbps	OFF	ON
500 kbps	ON	OFF
500 kbps	ON	ON

Table 4-1: Baud Rate

ON

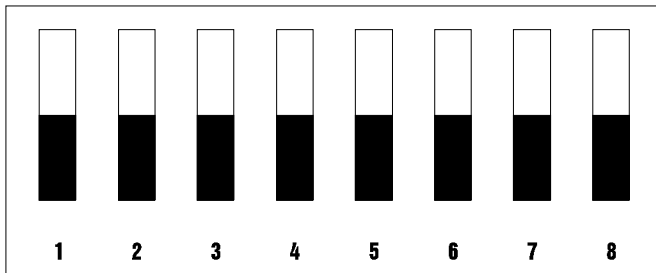

OFF

FIG. 4-2 FACTORY DEFAULT DIP SWITCH CONFIGURATION

Configuring the DeviceNet Node Address

Refer to Table 4-2 to configure the DeviceNet Node Address.

Address	S1-1	S1-2	S1-3	S1-4	S1-5	S1-6
0	OFF	OFF	OFF	OFF	OFF	OFF
1	OFF	OFF	OFF	OFF	OFF	ON
2	OFF	OFF	OFF	OFF	ON	OFF
3	OFF	OFF	OFF	OFF	ON	ON
“	“	“	“	“	“	“
62	ON	ON	ON	ON	ON	OFF
63	ON	ON	ON	ON	ON	ON

Table 4-2: DeviceNet Node Addresses

Any-Weigh™ Series Bench Scales

CHAPTER 5 - SETUP

SCOPE

All information contained in Chapter 5 pertains to software or firmware settings or procedures to prepare the DeviceNet Scale for calibration and operation. Alternatives to these procedures either explicit or implied, contained in this section are not recommended. It is very important that the user and service personnel be familiar with the procedures contained in this chapter, before going through the setup procedures.

NOTE:

The DeviceNet Scale is the only scale in the ANY-WEIGH series of scales that requires a setup. The Analog Scale requires calibration, please see Chapter 6 for the Analog Scale calibration procedures.

Saving to Non-Volatile Ram

To save parameters to non-volatile RAM, set parameter 38 (Save non-volatile command) to 1. This request should be sent after changing any configuration parameter. It does NOT need to be sent after altering a command parameters like TARE or ZERO. It does not need to be sent after doing a calibration. The necessary calibration data values are saved automatically. However, if you change parameters used during calibration, like “number of averages”, or “WAVERSAVER[®]” for example, the SAVE request should be sent BEFORE cycling the power.

The non-volatile RAM has a maximum of 5,000,000 writes.

Parameters

- Parameter 1 = Metric Poll
True = kgs net False = lbs net
Length in Bytes = 1

NOTE:

Default settings are indicated by bold type.

- Parameter 2 = WAVERSAVER[®] Setting
0 =OFF 1 = 4 Hz, **2 = 2Hz**, 3 = 1.0 Hz, 4 = 1/2 Hz
Length in Bytes = 1

Any-Weigh™ Series Bench Scales

NOTE:

By selecting OFF (0) or 1 the scale increases the updates per second from 10 to 55.

- Parameter 3 = Calibration Type
0 = Hard Cal, 1 = C2 Cal, Other = Not Cal'd
(Read Only)
Length in Bytes = 1
- Parameter 4 = Span Weight in Lbs
1 to 2147483647 **10000.000**
Length in Bytes = 4
- Parameter 5 = Averages
0 to 255 **10**
Length in Bytes = 1
- Parameter 14 = Number of C2® Chips Found
0 to 8 (Read Only)
Length in Bytes = 1
- Parameter 15 = Net Weight in Lbs
Read Only
Length in Bytes = 4
- Parameter 16 = Gross Weight in Lbs
Read Only
Length in Bytes = 4
- Parameter 17 = Tare Weight in Lbs
-999999 - 999999 **0.00**
Length in Bytes = 4
- Parameter 18 = Tare Command
0 to 1 (Set to True to Complete Command)
Length in Bytes = 1
- Parameter 19 = Zero Command
0 to 1 (Set to True to Complete Command)
Length in Bytes = 1
- Parameter 20 = Calibrate Low Command
0 to 1 (Set to True to Complete Command)
Length in Bytes = 1

- Parameter 21 = Calibrate High Command
0 to 1 (Set to True to Complete Command)
Length in Bytes = 1
- Parameter 22 = Calibrate using C2®
0 to 1 (Set to True to Complete Command)
Length in Bytes = 1
- Parameter 23 = Span Weight in Kgs
0.000 to 2147483.647 **0.045**
Length in Bytes = 4
- Parameter 30 = Net Weight in Kgs
Read Only
Length in Bytes = 4
- Parameter 31 = Gross Weight in Kgs
Read Only
Length in Bytes = 4
- Parameter 32 = Tare Weight in Kgs
-999999 - 999999 **0.00**
Length in Bytes = 4
- Parameter 34 = A/D Counts
Length in Bytes = 4
- Parameter 35 = Calibration Low Weight in Lbs.
Length in Bytes = 4
- Parameter 36 = Calibration Low Weight in Kgs.
Length in Bytes = 4

The “Calibration Low Weight” parameter specifies the weight on the scale when the low step of a calibration is done in Traditional Calibration and is the Reference Point for C2 Calibration.

- Parameter 37 = Weight Multiplier
Length in Bytes = 4

This integer parameter can be set to 1, 10, 100, etc. to allow the user to select the number of dec-

Any-Weigh™ Series Bench Scales

imal places in the 32 bit integer weight outputs. The value 0 causes these weight outputs to be in floating point format.

NOTE:

This applies ONLY to the weights as viewed through the I/O (Command) interface. The explicit message interface continues to use 3 decimal place 32 bit integer format only.

- Parameter 38 = Write non-volatile command.
Length in Bytes = 1

Setting this parameter to 1 will cause a save to non-volatile memory. Calibration data is saved to non-volatile memory automatically. Other parameters must be saved using this command.

- Parameter 30 = Parameter high word.
Length in Bytes = 2
This parameter is used in the command interface as described below:

Command Interface

The Command Interface allows easy access to all parameters without using explicit messages. The DeviceNet Scale produces 4 bytes of polled output data and consumes 4 bytes of polled input data. The 4 bytes of input data can be used to set parameters in the module and to specify what data should be placed in the 4 bytes of output data.

Format of Commands (4 byte input data)

Byte 0	Parameter value, least significant byte. (Used by the WRITE command only.)
Byte 1	Parameter value, second least significant byte. (Used by the WRITE command only.)
Byte 2	Parameter number. The parameter number is the instance of the parameter object. These are listed in the HI 200DNWM manual.
Byte 3	(Command byte): 0=READ command. 1 = WRITE command

Most of the DeviceNet Scales' parameters are only 1 byte long, making it possible to write them with a single command. There are also some 4 byte parameters. To write one of them:

- Step 1. First write the 2 most significant bytes, using a WRITE command as described above, with 0x27 in the parameter number field.
- Step 2. Write the least significant bytes using normal parameter numbers. The module will combine the value written to parameter 0x27 with the least significant bytes to produce the value written to the 4 byte parameter.

The 4 bytes written to the output table are as follows:

- If the Command byte of the input data is 0 (READ), the data is the value of the specified parameter, least significant byte first.
- If the specified parameter is an invalid number (0 for example: there is no parameter number 0), the data is net weight, with units as determined by the METRIC POLL parameter.
- If the Command byte of the input data is non-zero (WRITE), the output data echoes the input data.

**Examples
Using the
Command
Interface**

Reading Gross Weight in the polled output data.

1. First word (2 least significant bytes) of the input data is not used. Ignore.
2. Lower byte of second word is the parameter number. Gross weight in lbs is parameter #16.
3. Upper byte of second word set is "0" indicating read.

This causes the unit to output the Gross weight in lbs to the output polled data area. Resolution and data type would depend on the Weight Multiplier setting. Writing new value to number of averages.

Any-Weigh™ Series Bench Scales

1. First byte of first word on the input data is the new valued wanted.
2. Upper byte of first word should be 0 and is not used.
3. Lower byte of second word is the parameter number. Averages is parameter #5.
4. Upper byte of second word is set to “1” to indicate write.

This causes the unit to write the value in the first byte of the first word to the Averages parameter. During the execution of the command, the output polled data reflects the input polled data.

CHAPTER 6 - CALIBRATION

About Calibration of the DeviceNet, Analog and Universal Bench Scales

The DeviceNet and Analog version of bench scales come pre-calibrated from the factory. For the Universal version make sure it is correctly wired to the weighing instrument/indicator. Refer to the weighing instrument/indicator manual for calibration instructions.

C2 Second Generation Calibration

C2 electronically calibrates a scale system without the need for test weights. If you are using a Hardy Instruments Controller, Indicator or Weigh Module, all that's required is to enter a reference point. Refer to the instrument or module manual for instructions.

Test Weight Calibration (Hard Cal)

This is the traditional means of calibration requiring certified class F test weights equal to a minimum of 80% of the rated scale capacity. Additionally three weights between 10% and 100% of the scale capacity should be available to check the mid-range. Several low capacity weights equivalent to one or two instrument divisions are necessary to check the system sensitivity.

Material Substitution

When certified test weights are not available you can use an accurately weighed material to calibrate the system. In this method, a material is weighed on a secondary, calibrated scale and delivered to the site of the scale to be calibrated. The secondary calibrated scale should be of the same accuracy or greater and have a capacity approximately equal to the scale being calibrated.

Universal Scales HI SBU Series

Refer to the weighing instrument or module manual for calibration instructions. C2[®] Second Generation Calibration should only be used with Hardy weighing instruments.

DeviceNet Scales HI SBD Series

The ANY-WEIGH DeviceNet Scale series come pre-calibrated from the factory. If additional dead load is permanently attached to the scale surface, a recalibration may need to be performed.

THE BUTTON®

Enables one-touch electronic calibration of the scale when it is empty. Access to THE BUTTON and associated Module LED is located at the bottom of the scale through an access port. (See Fig. 6-1)

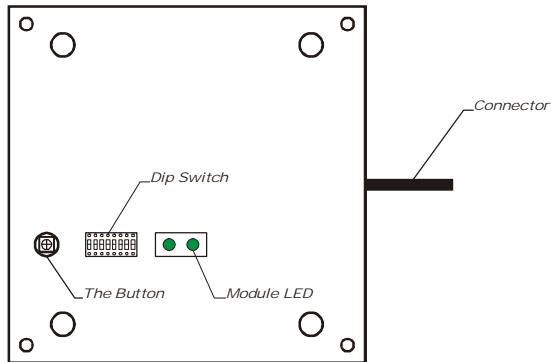

FIG. 6-1 THE BUTTON LOCATION/BOTTOM VIEW

- Step 1. Make sure that there is nothing in the vessel or on the scale.
- Step 2. Check to be sure that the Module LED is green.

- If the **Module LED is NOT green** do not complete the calibration.
- If the **Module LED is Green** go on to Step 3.

- Step 3. Press and hold the Red Button until the Module LED goes off. Keeping holding THE BUTTON down until the Module LED comes back on.
- Step 4. When the Module Status LED comes back on. Release the RED BUTTON. The weigh module system is calibrated.
- Step 5. If the LED does not come back on contact Hardy Technical Support for assistance.

C2® Calibration from RS NetWorx®

- Step 1. On the PC Desktop, open RS NetWorx®
- Step 2. Browse the Network.

- Step 3. Double click on the Node Icon of the weigh module you want to calibrate. For example: Node 36. The DeviceNet Weigh Module Dialog Box appears.
- Step 4. Click on the Parameter tab. The Parameter List appears with the information for the weigh module at address 36.
- Step 5. Click on Cal LO.
- Step 6. Enter the Cal LO value.
- Step 7. Click on the Apply button.
- Step 8. Click on Yes.
- Step 9. Click on C2 Cal Cmd.
- Step 10. Set the C2 Cal Cmd to "1".
- Step 11. Click on the Apply button.
- Step 12. Click on Yes.
- Step 13. Click on Cmd Save non-vol.
- Step 14. Set the Cmd Save non-vol to "1".
- Step 15. Click on the Apply button.
- Step 16. Click on Yes.
- Step 17. The calibration is complete.

NOTE: *Requires C2[®] load sensors or load points.*

NOTE: *RS NetWorx[®] is a registered trademark of Rockwell Automation.*

**Test Weight
Calibration from RS
NetWorx[®]**

- Step 1. On the PC open RS NetWorx[®]
- Step 2. Browse the Network.
- Step 3. Double click on the Node Icon of the weigh module you want to calibrate. For example: Node 36. The DeviceNet Weigh Module Dialog Box appears.
- Step 4. Click on the Parameter tab. The Parameter List appears with the information for the weigh module at address 36.
- Step 5. Click on Span Weight.
- Step 6. Enter the Span Weight Value.
- Step 7. Click on Cal LO.
- Step 8. Enter the Cal LO weight.
- Step 9. Click on Cal LO command.
- Step 10. Set the Cal LO to "1".
- Step 11. Click on the Apply button.
- Step 12. Click on Yes.

Any-Weigh™ Series Bench Scales

- Step 13. Place the test weight on the scale.
- Step 14. Click on Cal HI command.
- Step 15. Set the Cal HI command to “1”
- Step 16. Click on the Apply button.
- Step 17. Click on Yes.
- Step 18. Click on Cmd Save non-vol.
- Step 19. Set the Cmd Save non-vol to “1”.
- Step 20. Click on the Apply button.
- Step 21. Click on Yes.
- Step 22. The calibration is complete.
- Step 23. Click on Yes.
- Step 24. The calibration is complete.

Analog Scales HI SBA Series

The ANY-WEIGH Analog Scale series come pre-calibrated from the factory. If additional dead load is permanently attached to the scale surface a recalibration may need to be performed. All controls are accessible from the underside of the scale.

The ANY-WEIGH Analog Scale is calibrated at the factory for 4 mA current output with zero millivolt input and 20 mA output for 15 mV input. In some cases, the transmitter will require a very simple recalibration to the system in which it is installed. The calibration procedure provided in this section is designed to be used either in new installations or for recalibration of existing systems. Make sure that you read the Calibration Controls Section before calibrating the transmitter.

Calibration Controls

Coarse (ZERO)

The Coarse Control is used to remove large dead loads or offsets such as the weight of a container, and/or any other constant weight on the scale which is part of the weighing equipment itself. This control can subtract as much as 65% of full scale from the output.

Fine (ZERO)

This control is a fine offset adjustment. Its range is sufficient to fine tune the Coarse adjustment.

Span

This control adjusts the gain of the scale. It determines how many millivolts (of transducer signal) per

volt (of transducer excitation) will be represented by the 4-20 mA output range.

The gain can be adjusted from 3 mV input per volt of excitation to as high as 0.8 mV input per volt of excitation. This broad range of sensitivity allows for the wide variation in transducer range that remains after dead load compensation is subtracted by the Coarse Zero adjustment.

Calibration Procedures

NOTE:

The measuring instruments used in the following process must be designed so the test leads are isolated from ground. These are either “floating” and/or “isolated” and/or “differential” types.

NOTE:

Insertion of any measuring device, or voltage dropping resistor for a measuring device, in the output/power loop requires that the power supply voltage be high enough to supply the extra voltage.

- Step 1. Remove all weights from the scale. Allow dead load to remain. If dead load is counterbalanced, also allow counterbalancing to remain.
- Step 2. Install a millimeter, in series, into the output/power loop of the scale. If a voltmeter is to be used for measurements, and a resistor for calibration is not already installed in the system, install a 100 ohm, $\pm 0.1\%$, 1/4 W resistor, in series, into the output/power loop of the scale. Voltmeter readings are shown in parentheses.
- Step 3. If a voltmeter is used, attach the voltmeter across the 100 ohm resistor.
- Step 4. Adjust the transmitter Fine control for a 4 mA (0.4 V) reading on the meter. If necessary, center the Fine control and adjust the transmitter Coarse control first.
- Step 5. Place a know weight on the scale. If possible, use a full scale weight for best results.

Any-Weigh™ Series Bench Scales

Step 6. Adjust the SPAN for 20 mA (2 V) for full-scale weight. For less than full-scale weight, perform the following steps:

1. Divide: calibration weight/full-scale weight = (F)raction of full scale.
2. Multiply: (F)(16 mA) = 1, the current caused by the calibration weight.
3. Add: 1 + 4 mA = Calibration Current, 1c.
4. Adjust SPAN to produce the Calibration Current, 1c, in the output/power loop.

- For Example:

Calibration Weight = 750 pounds
Full Scale Capacity = 1000 pounds

Adjust SPAN for:

$$\begin{aligned}(750/1000)(16 \text{ mA}) + 4 \text{ mA} &= 1c \\(0.75)(16 \text{ mA}) + 4 \text{ mA} &= 1c \\12 \text{ mA} + 4 \text{ mA} &= 1c \\16 \text{ mA} &= 1c\end{aligned}$$

Step 7. Remove the calibration weight and recheck to see if the zero reading is still 4 mA (0.4 V). Adjust the Fine control if necessary.

Step 8. Place the calibration weight on the scale again and recheck to see if the calibration reading is correct.

- Adjust the SPAN if necessary.

Step 9. Repeat Steps 7 & 8 until no further adjustment is necessary to keep both measurements within the system tolerances.

Step 10. Calibration is complete. The resistor inserted for voltage checks may now be

removed, or it can be left in the circuit for future measurements. Neither action will interfere with the system operation.

Any-Weigh™ Series Bench Scales

CHAPTER 7 - OPERATION

SCOPE

All information contained in Chapter 7 pertains to the operation of the ANY-WEIGH Bench Scales. We recommend that the processes and procedures contained in this chapter be followed to insure that the module give the user maximum quality performance. It is very important that the user be familiar with this chapter before operating the weigh module.

Operating Capabilities

The ANY-WEIGH series of low profile bench scales are used in a broad range of industrial or laboratory applications. Some of these applications include:

- Filling
- Grading
- Check Weighing
- Proportioning
- Batching

DeviceNet Scale

Explicit Message Request Parameters

The procedures for sending the Explicit Message Requests are unique to each PLC and the user needs to refer to their PLC users guide, PLC DeviceNet Scanner section for instructions. The DeviceNet Scale needs the following information to respond to an Explicit Message Request:

- **SERVICE:** The DeviceNet Scale can process the “Get_Attribute_Single” (14) and “Set_Attribute_Single” (16).
- **CLASS:** The Device Net parameter Class is 15.
- **INSTANCE:** The DeviceNet parameter number can be found in the I&O section of this manual.
- **ATTRIBUTE:** The parameter value attribute number is 1.
- **DATA:** (varies)

NOTE:

Data length can vary, be sure to enter the correct length (size) of data or problems will occur.

Any-Weigh™ Series Bench Scales

NOTE:

Order of bytes must be least significant first.

Monitoring Weight Readings from RS NetWorx

- Step 1. On the PC open RS NetWorx.
- Step 2. Browse the Network.
- Step 3. Double click on the Node Icon of the weigh module you want to monitor. For example: Node 36. The DeviceNet Weigh Module Dialog Box appears for Node 36.
- Step 4. Click on the Parameters Tab.
- Step 5. All the parameters including the weights are displayed.
- Step 6. The NET, GROSS, and TARE weights are now being monitored.

Network Status (DS1)

STATE	LED	INDICATION
NOT POWERED/NOT ON LINE	OFF	DEVICE IS NOT ON LINE 1. NO POWER APPLIED 2. Dup_MAC_ID TEST NOT COMPLETE
OPERATIONAL AND ON-LINE	GREEN	ON LINE NORMAL CONDITION WITH CONNECTIONS ESTABLISHED.
OPERATION AND ON LINE NOT CONNECTED	FLASHING GREEN	ON LINE NORMAL CONDITION NO CONNECTIONS Dup_MAC_ID PASSED & ON LINE, NO CONNECTIONS TO OTHER NODES.
CRITICAL FAULT OR LINK FAILURE	RED	UNRECOVERABLE FAULT (MAY NEED REPLACING) FAILED COMMUNICATIONS (DUPLICATE Mac ID OR BUS OFF)

Table 7-1: NETWORK STATUS (DS1)

Scale Status (DS2)

STATE	LED	INDICATION
NOT POWERED/ NOT ON LINE	OFF	DEVICE IS NOT ON LINE 1. NO POWER APPLIED
OPERATIONAL	GREEN	NORM CONDITION

Table 7-2: SCALE STATUS

STATE	LED	INDICATION
MINOR FAULT AND/OR CONNECTION TIME-OUT	FLASHING RED	RECOVERABLE FAULT A/D ERROR, USUALLY CAUSED BY BAD CONNECTION TO LOAD CELLS LOAD CELL OUT OF RANGE. SENSE LINES MUST BE INSTALLED.
CRITICAL FAULT OR LINK FAILURE	RED	UNRECOVERABLE FAULT (Board may need replacing) FAILURE IN A-D

Table 7-2: SCALE STATUS

Analog Scale

The ANY-WEIGH Analog Scale powers itself and the attached strain gauge transducers from the 4-20 mA loop power. This allows sensitive strain gauge signals to be transmitted over long distances without the expense of installing additional power to remote locations. A common, low-cost power supply can be placed anywhere in the 4-20 mA loop.

As the power supply provides loop power, the Analog Scale controls the current flow (4-20 mA) representing the strain gauge signal and receiving devices can be placed anywhere along the loop to monitor current flow. Typical receiving devices include.

- Chart Records
- Panel Meters
- Bar Graphs
- Programmable Controllers
- Computers
- Relay Set Point Modules

Any-Weigh™ Series Bench Scales

CHAPTER 8 - TROUBLESHOOTING

SCOPE

All the information in Chapter 8 pertains to the troubleshooting and resolution of operating problems that may occur. All maintenance personnel and users should be familiar with Chapter 8 before attempting to repair the ANY-WEIGH Scale.

Problem:

Scale Does Not Respond When Weight is Applied

- Step 1. Make sure the scale is wired correctly to the instrument or network and there are no breaks in the wiring.
- Step 2. Check to see if there is packing material or debris wedged under or against the scale.

Scale Indication is not linear

- Step 1. Check the instrument for proper calibration.
- Step 2. Check to see if there is packing material or debris wedged under or on the side of the scale.
- Step 3. Make sure all electrical connections are tight with no corrosion and that there has not been an ingress of moisture to the system.

Scale Reads Backwards

- Step 1. Check for correct wiring to the instrument. The +/- signal or excitation wires may be reversed.

Scale Reading drifts or is Erratic

- Step 1. Make sure all electrical connections are tight with no corrosion and that there has not been an ingress of moisture to the system.
- Step 2. Verify that the instrument or network is operating properly.
- Step 3. Make sure there are no high voltage wires close to the scale.
- Step 4. Check that the scale and instrument are properly grounded.
- Step 5. If high static electricity is present a ground strap should be added from the top cover to the chassis and to earth ground.

Any-Weigh™ Series Bench Scales

DeviceNet Scale: Module LED does not Come Back on When Performing Calibration with The Button

Step 1. Indicates a hardware problem. Contact Hardy Technical Support for assistance.

DeviceNet Scale: Module LED is Flashing Red

Step 1. Check all the connections to be sure they are securely fastened.

Step 2. Reinstall if any appear to be loose.

Analog Scale: Malfunction, No Output

Step 1. Check voltage at + & - loop connections. The voltage should read 15 VDC to 50 VDC.

Step 2. Check all the connections to be sure they are securely fastened.

Step 3. If the voltage is correct and all connections are securely fastened, contact Hardy Technical Support Department.

Analog Scale: No Change in Input

Step 1. Check to see if the Load Cell signal output is below the original setting. If the signal level returned by the Load Cells is below the previous dead load setting, measure approximately 2.3 mA between the loop + and - terminals.

Step 2. Check to see if the Load Cell signal output is above the original setting. If the signal level returned by the Load Cell is above the previous Span setting, measure approximately 23 mA between the loop + and - terminals.

Analog Scale: Output Drifts

Step 1. Check all the load cell connections to be sure they are securely fastened.

Step 2. Check the Power Supply to make sure there is a constant voltage output.

Service and Repair (All Models)

For Service and Repairs, contact your local Hardy Representative.

Before returning any product to Hardy Instruments Inc., please contact the Hardy Service Center for a return authorization number. Please have the scale

model number and serial number and a brief description of the problem ready when you call.

Technical Support

Hardy Instruments, Inc.

9440 Carroll Park Drive, Suite 150

San Diego, CA 92121

Web-Site: <http://www.hardyinst.com>

US Customers Only: 800-821-5831

Outside the US: 858-278-2900

FAX: (858) 278-6700

Any-Weigh™ Series Bench Scales

Index

A

- About Calibration of the DeviceNet, Analog and Universal Bench Scales 6-1
- Accessing the DIP Switch 4-2
- Adjust the Leveling Feet 3-3
- Analog Scale 1-2, 3-5, 7-3
 - Malfunction, No Output 8-2
 - No Change in Input 8-2
 - Output Drifts 8-2
- Analog Scale Specifications 2-2
- Analog Scales HI SBA Series 6-4
- ANY-WEIGH Analog Scale 7-3
- Attribute 7-1

B

- Bases 1-1
- Baud Rate 4-1
- Baud Rates 2-2
- Browse the Network 6-2
- Build-Up of Debris 3-1

C

- C2 Second Generation Calibration 6-1
- C2[®] Calibration from a Personal Computer 6-2
- C2[®] Electronic Calibration 1-1
- Cal HI Command 6-4
- Cal LO Weight 6-3
- Calibration Controls 6-4
- Calibration Procedures 6-5
- Chassis Ground Attachment Point 4-2
- Class 7-1
- Coarse (ZERO) 6-4
- Command Interface 5-4
- Configuring the Baud Rate 4-2
- Configuring the DeviceNet Node Address 4-2

Any-Weigh™ Series Bench Scales

Covers 1-1

Creep 2-1

D

DATA 7-1

Deadloads 6-4

Description 1-1

DeviceNet Communication Configuration 4-1

DeviceNet Connection Wiring Diagram 3-4

DeviceNet Manager 6-2, 6-3

DeviceNet Network Cable 3-4

DeviceNet Node Address 4-2

DeviceNet Pin Out Diagram 3-4

DeviceNet Scale 3-4, 7-1

 Module LED is Flashing Red 8-2

DeviceNet Scale Specifications 2-2

DeviceNet Scales HI SBD Series 6-1

DeviceNet™ Network 1-2

DeviceNet™ Scale 1-2

DIP Switch (S1) Configuration 4-1

DIP Switch Location 4-1

Drawing # 0588-0097 3-5

E

Earth Ground 4-2

Electrical Specifications 2-1

Examples Using the Command Interface 5-5

Explicit Message Request Parameters 7-1

F

Fine (ZERO) 6-4

Format of Commands (4 **byte** Input Data) 5-4

G

Gross Weight in lbs 5-5

H

Hardy Any-Weigh™ Bench Scales 1-1

I

I/O Slave Messaging 2-2

Input Power 2-2

Input Resistance 2-1

Inputs 2-2

Instance 7-1

Introduction 1-1

L

Level the Corners 3-1

Leveling Feet 3-2

Leveling the Scale 3-1

Linearity 2-2

Loop Power 2-2

Loop Wires 3-5

Lower Frame Assembly 1-1

M

Material Substitution 6-1

Maximum Overload 2-1

Mechanical Dimensions 2-3

Micro DeviceNet Connector 3-4

Minimum Power Supply Voltage 3-5

Module LED 6-2

Module Status (DS2) 7-2

Monitoring Weight Readings 7-2

N

Network Status (DS1) 7-2

Node Address 4-1

Node Icon 6-3, 7-2

Non-Linearity 2-2

Non-Volatile RAM 5-1

Any-Weigh™ Series Bench Scales

O

- Operating Capabilities 7-1
- Output Resistance 2-1
- Outputs 2-2

P

- Parameters 5-1
- Preinstallation Precautions 3-1

R

- Rated Output 2-1
- Recommended DC or AC Excitation Voltage 3-3
- Resolution 2-2
- Response Time 2-3

S

- Safe Load Limi 2-1
- Saving to Non-Volatile Ram 5-1
- Scale does not respond when weight is applied 8-1
- Scale indication is not linear 8-1
- Scale Reading drifts or is Erratic 8-1
- Scale Reads Backwards 8-1
- Sensitivity 2-3
- Service 7-1
- Service and Repair 8-2
- Setpoints 5-6
- Shock Load and Corner Overload Protection 1-1
- Span 6-4
- Span Weight 6-3
- Spirit Level 3-1

T

- Temperature Coefficient 2-2, 2-3
- Temperature Effect 2-1
- Temperature Range 2-1, 2-2, 2-3
- Test Weight Calibration (Hard Cal) 6-1
- Test Weight Calibration Procedures 6-3

THE BUTTON[®] 6-2

The Stainless Steel Top Cover 1-1

Total Error 2-1

Type 2-2

U

Universal Scale Electrical Connections 3-3

Universal Scale Interface 1-1

Universal Scale Specifications 2-1

Universal Scales HI SBU Series 6-1

Unpacking 3-1

Update Rate 2-2

W

WAVERSAVER[®] 1-1

Wire the Scale Cable 3-3

Any-Weigh™ Series Bench Scales