

## SELECTION GUIDE

Load Sensors • Load Points • Bench Scales  
Floor Scales • Summing Cards • Junction Boxes • Cable

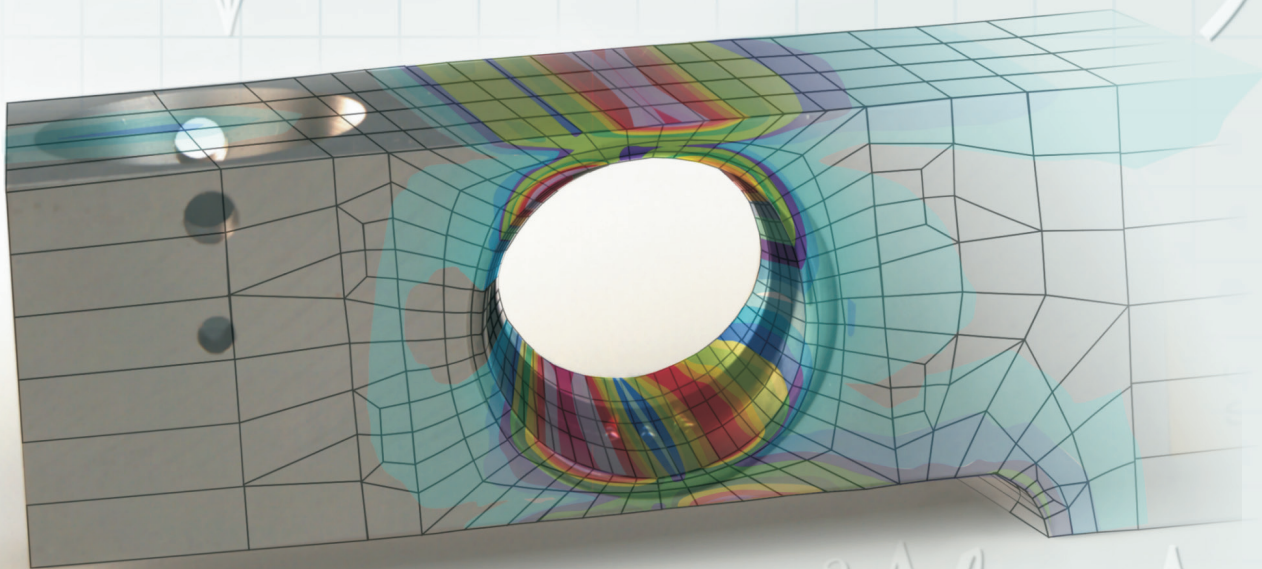
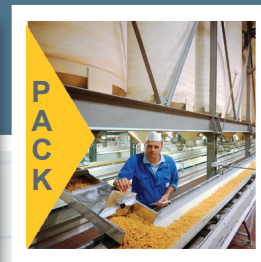

$$V_e = \frac{\sigma^2 A l}{2E}$$

$$\sigma = eE$$

$$\uparrow F$$

# ANATOMY OF A HARDY LOAD SENSOR

- **Blind Loading Hole**

- Allows a spherical end loading pin to insure load is applied at the same precise location, eliminating unwanted effects of side and eccentric loads common with threaded hole designs.

- **Hermetically Sealed & IP68 / IP69K (on select models) Rated**

- A nitrogen filled sensing area laser sealed by a welded sleeve and cable entry through a glass to metal header blocks moisture and protects circuits from corrosion for long sensor life, even in harsh environments.

- **Matched MV/V & MV/V/OHM**

- Each sensor produced is electrically matched to a standard resulting in no corner adjustments (trim pots) or recalibration required in platforms or hopper scales.

- **Additional 'O' Ring and Stuffing Gland**

- Provide additional protection from the environment.



- **Combined Error Reduced 50%**

- More consistent weight measurements, lower hysteresis and nonlinearity.

- **200% Safe Overload Limit**

- Less susceptibility to shock and pulsed loads.

- **Cylindrical Sleeve**

- The gauge area sealing shares much less of the applied load as compared to the conventional cup. This allows more of the applied load to be accurately sensed by the strain gauges.

- **316 Electro-polished Stainless Steel**

- Cable fittings and gauge area sleeve are polished for additional protection from corrosion.



- **Ready To Install Cable**

- Each sensor is shipped with cables stripped and wires tinned for easy installation.

- **Color Code Label**

- Identifies wires for easy installation.

All information and drawings on these pages are subject to change without notice. Consult website for latest specifications.

# ADVANTAGE® LINE - Attention to Detail

- **C2®, Second Generation Calibration**

*Allows fast, accurate system calibration without test weights.*

- **On-board Certs**

*The performance characteristics of each sensor are stored in an internal memory so you never lose the original certification data.*

- **Standard ¼ NPT Conduit Adapter**

*Allows conduit to be installed right to the load sensor, increasing system reliability.*

- **Potted Cable Enclosure**

*Proprietary material prevents moisture from contacting header terminals and wicks up cable approximately 6" providing added moisture barrier.*

All load cells look the same on the surface. It's the attention to detail beneath the surface that separates a Hardy ADVANTAGE® Line Load Sensor from the common load cell. You'll find details like a no-cost conduit adapter, redundant sealing for superior protection from moisture, matched parameters for easy sensor installation without corner adjusting, tighter specs for higher accuracy and individual performance certs posted on the web for easy access. It's attention to detail that saves you time and money. And it's Hardy Process Solutions that focuses on your specific technical and commercial needs incorporating all of the best features available in load cell manufacturing.

The same attention to detail shown in our Mid-Capacity sensor to the left can be found in Hardy's entire ADVANTAGE line.

The pages that follow should outline everything you need to specify your load point weighing requirements. If you need more information, our Maintenance and Installation manuals, as well as links to our local representatives, are available to you on the Internet at [www.hardysolutions.com](http://www.hardysolutions.com).

# ANATOMY OF A HARDY LOAD POINT

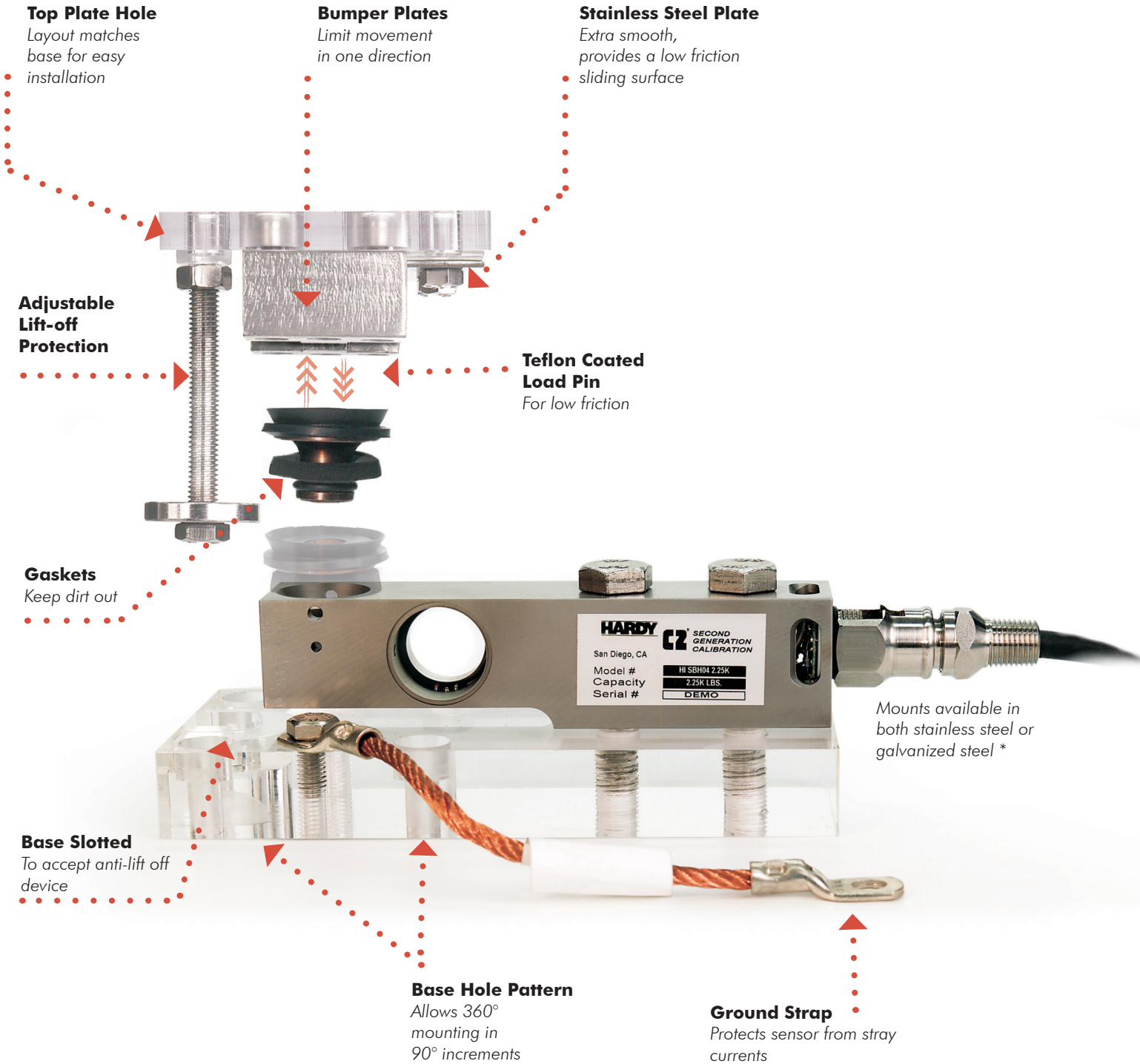

\*Shown in clear plastic for illustrative purpose only.

# The HARDY C2<sup>®</sup> Difference

- **FAST**  
Calibrates with ONE reference point, not FIVE
- **SAFE**  
Eliminates need for full-scale test weights
- **RELIABLE**  
Data stored in chip

Since 1994, thousands of weighing systems have been calibrated electronically using C2<sup>®</sup> Electronic Calibration by Hardy Process Solutions. Unlike calibration with test weights, all the live weight on the scale does not have to be removed and heavy test weights do not have to be repeatedly put on and off the scale. As soon as your scale system is installed, it can be C2 calibrated, and proper scale installation verified. The result is a calibration that is easier, quicker, safer, and typically more accurate than methods used in the past.

## What is a C2 system?

A C2 system includes load points, junction box, cabling and instrumentation, and is designed to make calibration easier than ever before. Upon installation or re-calibration, your Hardy instrument automatically searches for C2 certified load points and records their performance characteristics. Entering a reference point is all that's needed to bring your system on-line within seconds. On instruments with "THE BUTTON" feature, one touch of a button is enough. All that's left is to verify your scale. This is done by carefully distributing one or two small weights (25 to 100 lbs.) on to the scale so they are shared by all the load sensors. The scale reading should equal the value of the test weight/s applied. Remove the weight/s and the scale reading should return to its original value. If both of these are true then the scale is calibrated, verified and ready for use. If the values are not true, then there are mechanical problems with the scale that need to be corrected.

## Is C2 Electronic Calibration as accurate as calibration with test weights?

Theoretically, test weights should provide an accurate calibration within the quality of the scale installation. However, calibration conditions are often less than ideal. Many vessels lack the space needed to place enough test weights on them to get an accurate calibration. Distributing the weights equally on the vessel may also be impossible. Some vessels are mounted in areas offering limited accessibility, while others have weight capacities far in excess of available test weights. These real world issues often cause calibration errors.

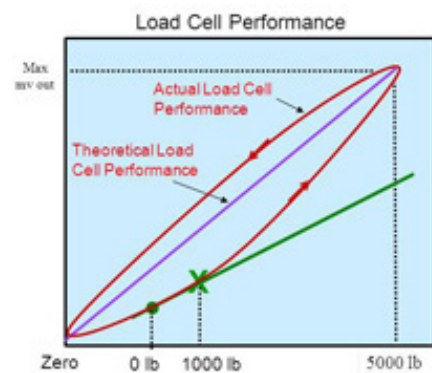
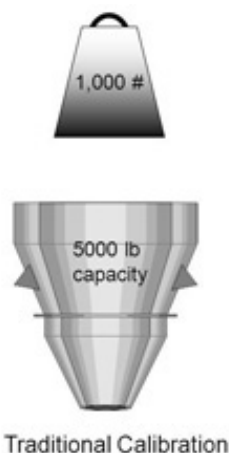

A 1000 lb test weight(s) added to set the Span

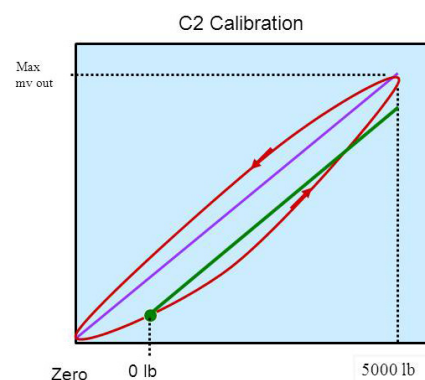
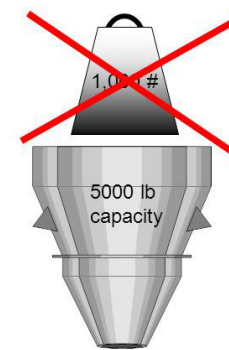

A Calibration is performed by a push of a button or a digital command

With C2, these considerations are no longer an issue. Each individual load sensor has its performance characteristics stored on an internal memory device. These characteristics are measured on National Institute of Standards and Technology (NIST) traceable test devices and electronically recorded when the sensor is manufactured. The C2 system uses these parameters, the instruments' characteristics and a reference point to calibrate the scale system.

C2 reduces downtime for repairs and time waiting for test weights. It eliminates test weight related injuries and ends material substitution headaches, including contamination and waste disposal issues. C2 is a standard feature on Hardy load sensors, weigh modules, and weight and rate controllers.

# SELECTING SINGLE LOAD POINTS

## ADVANTAGE LINE - Load Points/Sensors

Hardy's ADVANTAGE® Line load point assemblies are designed to provide exceptional performance in a safe and predictable manner. The load point consists of a precision, C2® load sensor assembled with matched mounting hardware. Each load point comes with an installation and maintenance manual which is also available for download from our Internet site at [www.hardysolutions.com](http://www.hardysolutions.com).

All Advantage sensors are designed with safe and ultimate loading limits which are the highest in the industry. The safe limit (200% of rated capacity) is that value above which some degradation of calibration can occur but with no permanent shift in performance. The ultimate limit (300% of rated capacity) is that point at which physical failure may occur. In selecting a load point, it is essential that the gross loadings that are anticipated fall well within the safe limits of the capacity chosen.

All Advantage load sensors are matched and calibrated for mV/V/ohm and mV/V. This removes the need for potentiometers in the summing junction box and allows a load sensor to be replaced in a weigh system without the need to re-calibrate the system.

Advantage load sensors are very accurate when the load is applied in the correct manner. Our mounting hardware is designed to direct the load properly to the load sensor while resisting angular effects and reducing moment sensitivity.

Free sliding Advantage mounts permit thermal expansion and contraction and are self checking with lift-off protection. With many years of process weighing experience, Hardy has incorporated mount designs into its load point assemblies to provide you with optimum performance.

## Selection of Load Points

The following steps will quickly isolate which individual load sensors or load point assemblies will satisfy your application.

1. Determine whether the vessel to be weighed will be hung in tension or set on top of the load point assemblies in compression. Count the number of support points.
  2. Determine the unloaded weight of the scale structure, vessel and all equipment to be mounted (valves, gates, vibrators, etc.) on (from) the load points. This is called the "Dead Load" (DL).
  3. Determine the maximum total weight of the heaviest material to be weighed. This is called the "Live Load" (LL).
  4. Calculate each load sensor's required capacity.
- $$\text{Load Sensor Capacity Range} = \frac{\text{Dead Load} + \text{Live Load}}{\text{Number of Support Points}}$$
5. Use the Load Point Selection Chart to determine the load point assembly appropriate for your installation.

SINGLE LOAD POINT			
CAPACITY		MODEL#	
SINGLE PT.	lbs	Kg	
5 - 16.5		2.5 - 7.5	HI SP1-7.5
16.6 - 22		7.6 - 10	HI SP1-10; HI SP6-10
22.1 - 33		10.1 - 15	HI SP1-15
33.1 - 44		15.1 - 20	HI SP6- 20
44.1 - 66		20.1 - 30	HI SP1 - 30
66.1 - 110		30.1 - 50	HI SP1-50; HI SP6-50
110.1 - 165		50.1 - 75	HI SP1-75
165.1 - 220		75.1 - 100	HI SP1-100; HI SP6-100
220.1 - 440		100.1 - 200	HI SP1-200; HI SP6-200
LOW CAP.	lbs	Kg	
20 - 44		9 - 20	HI LPB44-4__B,F,S
45 - 110		20 - 50	HI LPB110-4__B,F,S
111 - 225		50 - 102	HI LPB225-4__B,F,S
226 - 450		103 - 204	HI LPB450-4__B,F,S
MID CAP.	lbs	metric ton	
451 - 1125		0.21 - 0.51	HI HLPS1125-4__B,F,S
1126 - 2.25K		0.51 - 1.02	HI HLPS2.25K-4__B,F,S
2.251K - 4.5K		1.02 - 2.04	HI HLPS4.5K-4__B,F,S
4.51K - 11.25K		2.04 - 5.1	HI HLPS11.25K-4__B,F,S
11.25K - 22.5K		5.1 - 10.2	HI HLPS22.5K-4__B,F,S
HIGH CAP.	lbs	metric ton	
22.6K - 33K		10.2 - 15	HI LPRA33K-4__C
33.1K - 50K		15 - 22.7	HI LPRA50K-4__C
50.1K - 66K		22.7 - 30	HI LPRC03-66K-4__C
66.1K - 88K		30 - 40	HI LPRC03-88K-4__C
88.1K - 110K		40 - 50	HI LPRC03-110K-4__C
110.1K - 220K		50 - 100	HI LPRC03-220K-4__C
220.1K - 330K		100 - 150	HI LPRC03-330K-4__C
330.1K - 660K		150 - 300	HI LPRC03-660K-4__C
TENSION	lbs	Kg	
100 - 225		45 - 102	HI HLPT225-4__C
226 - 450		102 - 104	HI HLPT450-4__C
451 - 1125		204 - 510	HI HLPT1125-4__C
TENSION	lbs	metric ton	
1126 - 2.25K		0.51 - 1.02	HI HLPT2.25K-4__C
2.25K - 4.5K		1.02 - 2.04	HI HLPT4.5K-4__C
4.5K - 11.25K		2.04 - 5.1	HI HLPT11.25K-45C

REFER TO PAGE 8  
FOR SPECIFICATIONS

REFER TO PAGE 10  
FOR SPECIFICATIONS

REFER TO PAGE 12  
FOR SPECIFICATIONS

REFER TO PAGE 14-16  
FOR SPECIFICATIONS

REFER TO PAGE 18  
FOR SPECIFICATIONS

(F) fixed, (B) bumper & (S) slider -4\_\_ : -43 = STAINLESS  
-45 = PLATED

All information and drawings on these pages are subject to change without notice. Consult website for latest specifications.

# SELECTING LOAD POINT SYSTEMS

## System Selection

You can also determine the load point system required by calculating the system total load. The system will contain the appropriate load points for your system ordered under one number.

1. Determine whether the vessel to be weighed will be suspended in tension or set on top of the load point assemblies in compression. Count the number of support points.
2. Determine the unloaded weight of the scale structure, vessel and all equipment to be mounted (valves, gates, vibrators, etc.) on (from) the load points. This is called the "Dead Load" (DL).
3. Determine the maximum total weight of the heaviest material to be weighed. This is called the "Live Load" (LL).
4. Calculate the system capacity.

$$\text{System Capacity} = (\text{DL}) + (\text{LL})$$

5. Based on the number of support points, look in either the 3 or 4 point system column of the Load Point Selection Chart (below) and find the range the system capacity falls in. The model number to the right is the load point system you will require. For higher capacities, just use the Single Load point chart to the left and multiply those values by 3 or 4. Add a junction box and cable from page 22 of this guide to interface with your instrument requirements, and your system is complete.

## Environment

The environment where the load point is to function may be a factor in selection. For example, the Advantage load sensors are designed to operate at temperatures of 175°F to -40°F; for higher temperature, special load sensors are available. Advantage sensors are hermetically sealed in the gauge area and at the cable entry allowing them to be classified at IP68. This rating provides protection from the entry of dust and the full long-term immersion in water. The sensors and mounts (-43) are made of 17-4 stainless steel, providing a high degree of chemical corrosive resistance to solvents, alkalis and acids. Even the bolts are stainless steel and are rated to meet the sensors capacity. You can select zinc-plated steel mounting hardware for less rigorous environments. The -45 series of Load Points are plated with 12-15um Electro Zinc plus Yellow Chromate Dip.

- The long-term corrosion resistance of zinc is directly proportional to thickness. Typically commercial coatings are 3-5um thick, Hardy specifies a heavier coating of 12-15um.
- The electro zinc plating is enhanced by chemical chromate passivation conversion which applies a harder surface film, referred to as ZYC (zinc yellow chromate).
- In dry indoors environments this plating's service life prior to first signs of corrosion can be greater than 20yrs.

Refer to [www.hardysolutions.com](http://www.hardysolutions.com) for PDF and CAD drawings.

3 POINT SYSTEM			
CAPACITY		MODEL#	
LOW CAP.	lbs	Kg	
60 - 132		27 - 60	HI 3B132-4__
133 - 330		60 - 150	HI 3B330-4__
331 - 675		150 - 306	HI 3B675-4__
676 - 1350		306 - 612	HI 3B13.5K-4__
MID CAP.	lbs	metric ton	
1351 - 3375		0.61 - 1.53	HI 3S3375-4__
3376 - 6.75K		1.53 - 3.06	HI 3S6.75K-4__
6.75K - 13.5K		3.06 - 6.12	HI 3S13.5K-4__
13.5K - 33.75K		6.12 - 15.3	HI 3S33.75K-4__
33.75K - 67.5K		15.3 - 30.6	HI 3S67.5K-4__
TENSION	lbs	Kg	
300 - 675		136 - 306	HI 3T675-4__
676 - 1350		307 - 612	HI 3T675-4__
1351 - 3375		613 - 1530	HI 3T675-4__
TENSION	lbs	metric ton	
3376 - 6.75K		1.5 - 3.1	HI 3T6.75K-4__
6.75K - 13.5K		3.1 - 6.1	HI 3T13.5K-4__
13.5K - 33.75K		6.1 - 15.3	HI 3T33.75K-45

4 POINT SYSTEM			
CAPACITY		MODEL#	
LOW CAP.	lbs	Kg	
80 - 176		36 - 80	HI 4B176-4__
177 - 440		80 - 200	HI 4B440-4__
441 - 900		200 - 408	HI 4B900-4__
901 - 1.18K		408 - 816	HI 4B1.8K-4__
MID CAP.	lbs	metric ton	
1.8K - 4.5K		0.82 - 2.04	HI 4S4.5K-4__
4.5K - 9K		2.04 - 4.08	HI 4S9K-4__
9K - 18K		4.08 - 8.16	HI 4S18K-4__
18K - 45K		8.16 - 20.4	HI 4S45K-4__
45K - 90K		20.4 - 40.8	HI 4S90K-4__
TENSION	lbs	Kg	
400 - 900		181 - 408	HI 4T900-4__
901 - 1800		409 - 816	HI 4T1.8K-4__
1801 - 4500		817 - 2035	HI 4T4.5K-4__
TENSION	lbs	metric ton	
4.5K - 9K		2 - 4.1	HI 4T9K-4__
9K - 18K		4.1 - 8.2	HI 4T18K-4__
18K - 45K		8.2 - 20.4	HI 4T45K-45

# SINGLE POINT SERIES

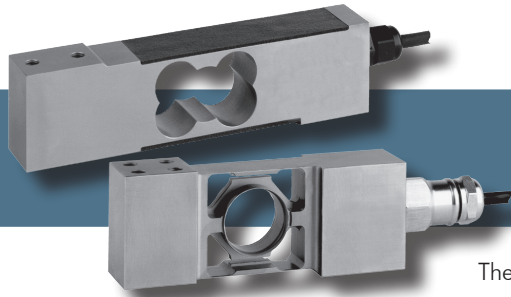

## HI SP1 and SP6 Single Point Load Sensors

The Hardy Process Solutions HI SP Series of single point load cells are designed for the OEM, conveyor and bench scale markets which require a low sensitivity to off center loads. They are built to perform in harsh environments found in the food, chemical and allied industries. The sensors are 17-4 PH stainless steel, with C2<sup>®</sup> calibration capabilities and come with three meters (9-10 ft) of cable.

The HI SP1 is available in capacities from 7.5kg to 200kg (16.5 to 440lbs), are environmentally protected with a plastic covering to IP67 (IP65 for 7.5 and 10kg) and have an integral mounting spacer.

The HI SP6 is available in capacities from 10kg to 200kg (22 to 440lbs), are completely hermetic sealed to IP68 and have an integral mounting spacer.

SPECIFICATIONS	SP1	SP6
Rated Output (ES)	2±0.10mV/V	2±0.10mV/V
Non-Linearity	<±0.0166 % R.O.	<±0.0166 % R.O.
Hysteresis	<±0.0166 % R.O.	<±0.0166 % R.O.
Zero Balance	<±5.0 % R.O.	<±5.0 % R.O.
Combined Error	<±0.02	<±0.02
Creep @ 30 Min.	<±0.0166 % R.O.	<±0.0166 % R.O.
Temp Effect Output	<±0.0140 % R.O./C	<±0.0112 % R.O./C
Temp Effect Sensitivity	<±0.010 % R.O./C	<±0.010 % R.O./C
Input Resistance	390 ±0.20 % ohm	1100 ±0.050 % ohm
Output Resistance	330 ± 0.25 % ohm	960 ± 0.050 % ohm
Insulation Resistance	>5000 Mohm	>5000 Mohm
Excitation	5 - 15 vdc	5 - 15 vdc
Safe Load Limit	200 % Emax	200 % Emax
Ultimate Load	300 % Emax	300 % Emax
Safe Side Load	100 % Emax	100 % Emax
Warranty	Two years	Two years

### ORDERING INFORMATION

No mounting hardware. Shipping Wt. approx. 4 lbs. for SP6, 3 lbs. SP1.

Capacity		Model#
lbs	kg	Load Sensor
22	10	HI SP6-10
44	20	HI SP6-20
110	50	HI SP6-50
220	100	HI SP6-100
440	200	HI SP6-200

Capacity		Model#
lbs	kg	Load Sensor
16.5	7.5	HI SP1-7.5
22	10	HI SP1-10
33	15	HI SP1-15
66	30	HI SP1-30
110	50	HI SP1-50
165	75	HI SP1-75
220	100	HI SP1-100
440	200	HI SP1-200



## SPI Single Point Outline

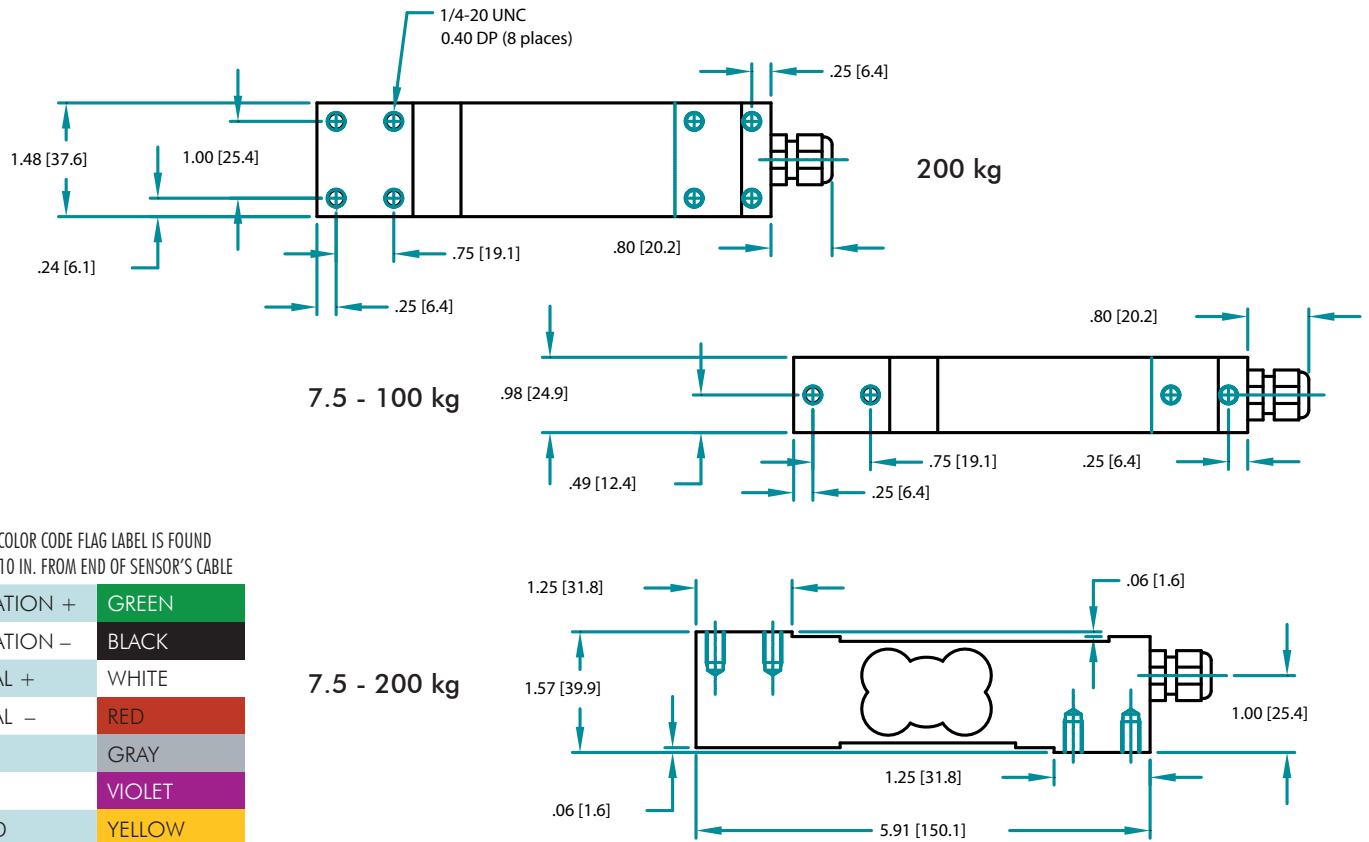

C2 WIRE COLOR CODE FLAG LABEL IS FOUND APPROX. 10 IN. FROM END OF SENSOR'S CABLE

EXCITATION +	GREEN
EXCITATION -	BLACK
SIGNAL +	WHITE
SIGNAL -	RED
C2+	GRAY
C2 -	VIOLET
SHIELD	YELLOW

WARNING: NEVER cut load sensor cable

CABLE LENGTH 9-10 FEET

## SP6 Single Point Outline

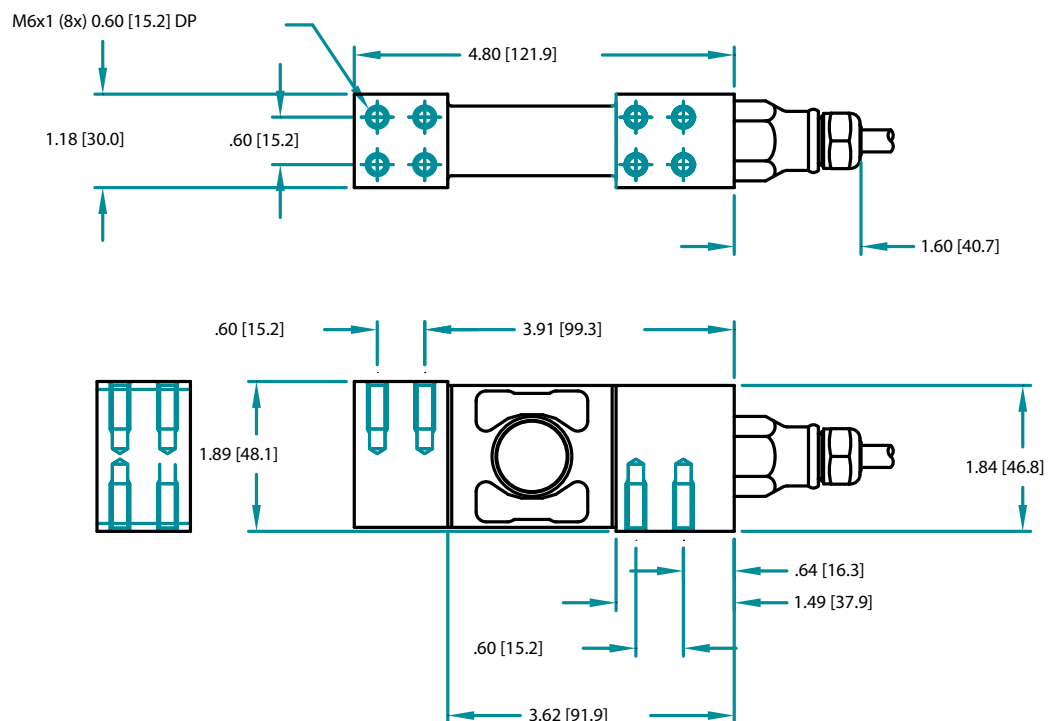

# ADVANTAGE LINE - LOW CAPACITY

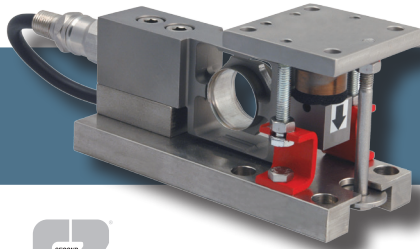

## HI LPB Hermetic Load Point Assembly Compression

The Hardy HI LPB ADVANTAGE® Series, sliding load point system is designed for use on light to medium capacity vessels.

Each load point consists of mounting hardware and a stainless steel mV/V and mV/V/ohm matched load sensor with true hermetic sealing, C2® Electronic Calibration capabilities, on-board electronic certs, a ¼ NPT conduit adapter and ten feet of cable. Each pre-assembled, low profile load point system provides lift off protection and consists of three mount types specifically designed to eliminate the effects of unwanted forces to provide exceptional accuracy. The assembly can be positioned 360 degrees in ninety degree steps. A grounding strap and fixed color code wiring label is provided with each load point. The mounting hardware is available in either stainless or zinc plated steel. The sensors have an IP rating of IP68/IP69K.

The HI LPB is available in the following standard capacities: 44 lbs, 110 lbs, 225 lbs, 450 lbs, and come fully assembled with shipping bracket for protection.

### SPECIFICATIONS

Rated Output (ES)	2±0.002mV/V
Non-Linearity	<±0.018 % R.O.
Hysteresis	<±0.025 % R.O.
Zero Balance	<±1.0 % R.O.
Creep @ 5 Min.	<±0.01 % R.O.
Temp Effect Output	<±0.0014 % R.O./C
Temp Effect Sensitivity	<±0.0007 % R.O./C
Input Resistance	1050 to 1150 ohms
Output Resistance	1000 ± 2 ohm
Insulation Resistance	>5000 Mohm
Excitation	5 - 15 vdc
Safe Load Limit	200 % Emax
Ultimate Load	300 % Emax
Safe Side Load LC	100 % Emax
Safe Side Load LP	50 % Emax
Max Lift Off	3.6 Klbs.
Warranty	Two years

### ORDERING INFORMATION

Load Point with Stainless Hardware (-43\_) shown, zinc plated Hardware (-45\_).  
Shipping Weight approx.6.5 lbs., Sensor 2.5 lbs.

A vessel with 3 legs will require 1 each fixed (F), bumper (B) & slider (S) assy.

A vessel with 4 legs will require 1 each fixed (F), bumper (B) & 2 each slider (S) assy.

Capacity	Model #	Model#	Model#	Model#	
lbs	Kgs	FIXED Assy	BUMPER Assy	SLIDER Assy	SPARE Load Sensor
44	20	HI LPB44-43F	HI LPB44-43B	HI LPB44-43S	HI BBH06-44
110	50	HI LPB110-43F	HI LPB110-43B	HI LPB110-43S	HI BBH06-110
225	100	HI LPB225-43F	HI LPB225-43B	HI LPB225-43S	HI BBH06-225
450	200	HI LPB450-43F	HI LPB450-43B	HI LPB450-43S	HI BBH06-450

Load points can be ordered as a system rather than ordering individual components.

### 3 POINT SYSTEMS

CAPACITY		MODEL#
lbs	Kg	
132	60	HI 3B132-43
330	150	HI 3B330-43
675	306	HI 3B675-43
1350	612	HI 3B1.35K-43

### 4 POINT SYSTEMS

CAPACITY		MODEL#
lbs	Kg	
176	80	HI 4B176-43
440	200	HI 4B440-43
900	408	HI 4B900-43
1800	816	HI 4B1.8K-43

## ADVANTAGE Load Point Outline

### HI LPB Series

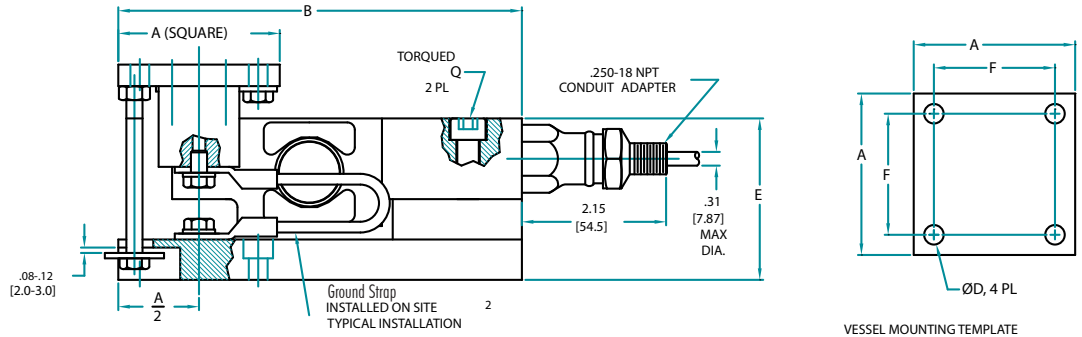

VESSEL MOUNTING TEMPLATE

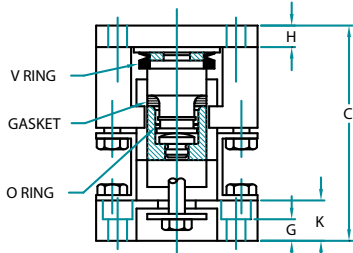

**2-Directional Bumper Module (B)**

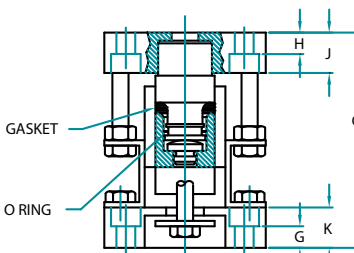

**Fixed Loading Pin Module (F)**

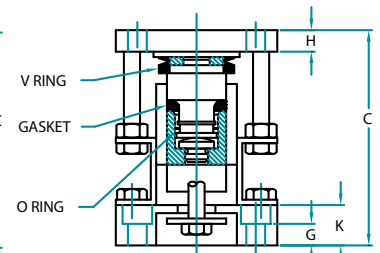

**Free Sliding Module (S)**

C2 WIRE COLOR CODE FLAG LABEL IS FOUND APPROX. 10 IN. FROM END OF SENSOR'S CABLE

EXCITATION +	RED
EXCITATION -	BLACK
SIGNAL +	GREEN
SIGNAL -	WHITE
C2+	GRAY
C2 -	VIOLET
SHIELD	YELLOW

#### DIMENSIONS- INCHES & [mm]

CAPACITY LBS (kg/kN)	A	B	C	ØD	E	F	G	H	J	K	ØL	Q FT LBS	MOUNT SCREW	WEIGHT LBS
44, 110, 225, 450 [20] [50] [1] [2]	2.36 [60.0]	5.91 [150.0]	3.15 [80.0]	0.276 [7.00]	2.36 [60.0]	1.73 [44.0]	0.315 [8.00]	0.315 [8.00]	0.59 [15.0]	0.59 [15.0]	0.433 [11.00]	18.5 [25Nm]	.250	6.5

WARNING: NEVER cut load sensor cable  
CABLE LENGTH 10 FEET

## ADVANTAGE Load Sensor Outline

### HI BBH06 Series

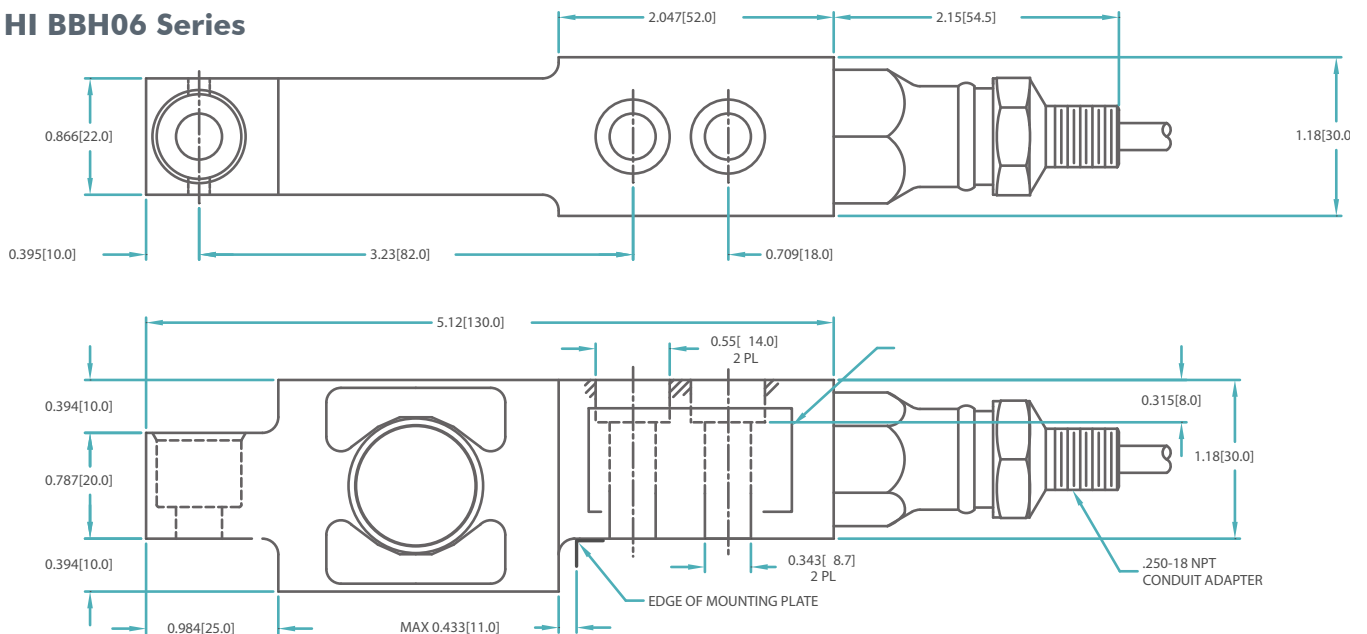

# ADVANTAGE LINE - MEDIUM CAPACITY

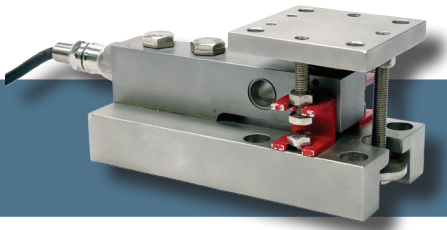

## HI HLPS Hermetic Load Point Assembly Compression

The Hardy HI HLPS ADVANTAGE® Series, sliding load point system is designed for use on medium to high capacity vessels.

Each load point consists of mounting hardware and a stainless steel mV/V and mV/V/ohm matched load sensor with true hermetic sealing, C2® Electronic Calibration capabilities, on-board electronic certs, a ¼ NPT conduit adapter and twenty feet of cable. Each pre-assembled, low profile load point system provides lift off protection and consists of three mount types specifically designed to eliminate the effects of unwanted forces to provide exceptional accuracy. The assembly can be positioned 360 degrees in ninety degree steps. A grounding strap and fixed color code wiring label is provided with each load point. The mounting hardware is available in either stainless or zinc plated steel. The sensors have an IP rating of IP68/IP69K and are NTEP Class III.

The HI HLPS is available in the following standard capacities: 1,125 lbs, 2.25K lbs, 4.5K lbs, 11.25K lbs, 22.5K lbs and are fully assembled with shipping bracket for protection.

### SPECIFICATIONS

Rated Output (ES)	2±0.002mV/V
Non-Linearity	<±0.018 % R.O.
Hysteresis	<±0.025 % R.O.
Zero Balance	<±1.0 % R.O.
Creep @ 5 Min.	<±0.010 % R.O.
Temp Effect Output	<±0.0012 % R.O./C
Temp Effect Sensitivity	<±0.0010 % R.O./C
Input Resistance	1106 ± 5 ohm
Output Resistance	1000 ± 1 ohm
Insulation Resistance	>5000 Mohm
Excitation	5 - 15 vdc
Safe Load Limit	200 % Emax
Ultimate Load	300 % Emax
Safe Side Load LC	100 % Emax
Safe Side Load LP	50 % Emax
Max Lift Off	6.6 Klbs (1.125K to 4.5K cap) 10.4 Klbs (11.25K Cap) 15.2 Klbs (22.5K Cap)
Warranty	Two years

### ORDERING INFORMATION

Load Point with Stainless Hardware (-43\_) shown, zinc plated Hardware (-45\_) Shipping Weight approx. 12-57 lbs. for Load Point, 4-60 lbs. for a Sensor.

A vessel with 3 legs will require 1 each fixed (F), bumper (B) & slider (S) assy.

A vessel with 4 legs will require 1 each fixed (F), bumper (B) & 2 each slider (S) assy.

Capacity		Model #	Assy #			Model#
lbs	mt		FIXED	BUMPER	SLIDER	SPARE Load Sensor
1,125	0.5	HI HLPS1125-43__	F	B	S	HI SBH04-1125
2.25K	1	HI HLPS2.25K-43__	F	B	S	HI SBH04-2.25K
4.5K	2	HI HLPS4.5K-43__	F	B	S	HI SBH04-4.5K
11.25K	5	HI HLPS11.25K-43__	F	B	S	HI SBH04-11.25K
22.5K	10	HI HLPS22.5K-43__	F	B	S	HI SBH04-22.5K

Load points can be ordered as a system rather than ordering individual components.

### 3 POINT SYSTEMS

CAPACITY		MODEL#
lbs	mt	
3,375	1.5	HI 3S3375-43
6.75K	3.1	HI 3S6.75K-43
13.5K	6.1	HI 3S13.5K-43
33.75K	15.3	HI 3S33.75K-43
67.5K	30.6	HI 3S67.5K-43

### 4 POINT SYSTEMS

CAPACITY		MODEL#
lbs	mt	
4.5K	2.0	HI 4S4.5K-43
9K	4.1	HI 4S9K-43
18K	8.2	HI 4S18K-43
45K	20.4	HI 4S45K-43
90K	40.8	HI 4S90K-43

All information and drawings on these pages are subject to change without notice. Consult website for latest specifications.

## ADVANTAGE Load Point Outline

### HI HLPS Series

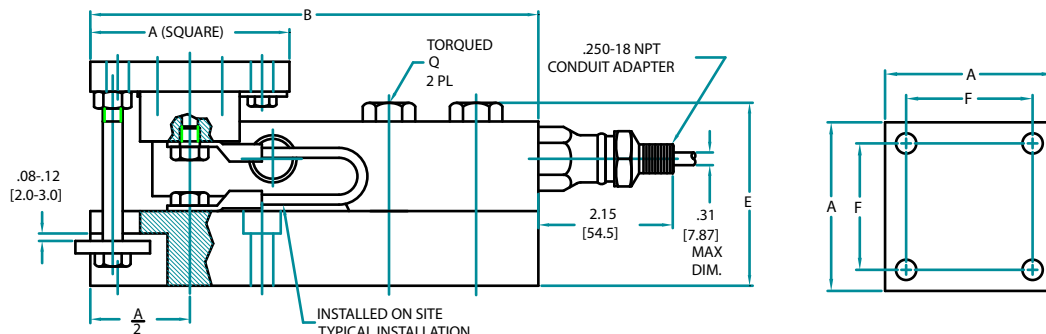

C2 WIRE COLOR CODE FLAG LABEL IS FOUND APPROX. 10 IN. FROM END OF SENSOR'S CABLE

EXCITATION +	RED
EXCITATION -	BLACK
SIGNAL +	GREEN
SIGNAL -	WHITE
C2 +	GRAY
C2 -	VIOLET
SHIELD	YELLOW

WARNING: NEVER cut load sensor cable

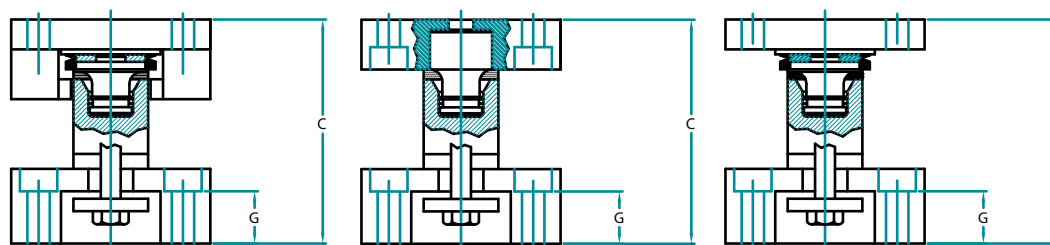

2-Directional Bumper Module (B) Fixed Loading Pin Module (F) Free Sliding Module (B)

CABLE LENGTH 20 FEET

DIMENSIONS- INCHES & [mm]

CAPACITY LBS [kN]	A	B	C	ØD	E	F	G	H	J	K	L	ØM	Q FT LBS	MOUNT SCREW	WEIGHT LBS
1.125K, [5] 2.25K, [10] 4.5K [20]	3.15 [80.0]	7.09 [180.0]	3.54 [90.0]	0.354 [9.00]	2.91 [74.0]	2.28 [58.0]	0.83 [21.0]	0.47 [12.0]	0.43 [11.0]	0.79 [20.0]	1.18 [30.0]	0.591 [15.00]	65 [70Nm]	.312	12
11.25K [50]	3.94 [100.0]	8.66 [220.0]	4.72 [120.0]	0.433 [11.00]	4.02 [102.0]	2.99 [76.0]	0.98 [25.0]	1.14 [29.0]	0.59 [15.0]	0.98 [25.0]	1.57 [40.0]	0.709 [18.00]	295 [400Nm]	.375	24
22.5K [100]	4.72 [120.0]	10.83 [275.0]	6.69 [170.0]	0.571 [14.50]	5.83 [148.0]	3.54 [90.0]	1.85 [47.0]	0.79 [20.0]	0.67 [17.0]	1.18 [30.0]	2.36 [60.0]	0.866 [22.00]	515 [700Nm]	.500	56.2

## ADVANTAGE Load Sensor Outline

### HI SBH04 Series

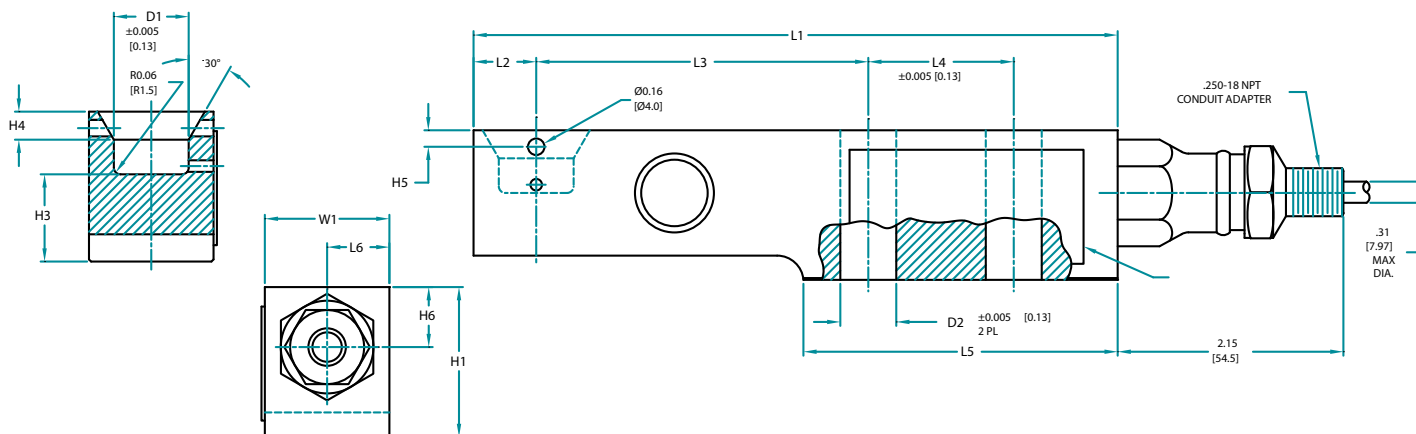

DIMENSIONS- INCHES & [mm]

TOLERANCES: ±0.010 [0.25] UNLESS OTHERWISE STATED

CAPACITY LBS [kN]	L1	L2	L3	L4	L5	L6	H1	H2	H3	H4	H5	H6	W1	ØD1	ØD2	BOLT	TORQUE
1.125K [5] 2.25K [10] 4.5K [20]	6.10 [155.0]	0.59 [15.0]	3.15 [80.0]	1.38 [35.0]	2.98 [75.7]	0.59 [15.0]	1.42 [36.0]	0.23 [5.8]	0.83 [21.0]	0.27 [6.9]	0.16 [4.1]	0.59 [15.0]	1.181±0.003 [30.0±0.08]	0.709 [18.0]	0.53 [13.5]	.500-20 UNC GRADE 5 [M12 8.8]	65 FT LBS [90Nm]
11.25K [50]	7.48 [190.0]	0.83 [21.0]	4.13 [105.0]	1.57 [39.9]	3.66 [93.0]	0.66 [16.8]	1.93 [49.0]	0.31 [7.9]	1.12 [28.5]	0.23 [5.8]	0.31 [7.9]	0.89 [22.5]	1.693±0.003 [43.0±0.08]	0.984 [25.0]	0.85 [21.5]	.750-10 UNC GRADE 5 [M20 8.8]	295 FT LBS [400Nm]
22.5K [100]	9.65 [245.0]	1.19 [30.2]	5.31 [134.9]	1.97 [50.0]	4.72 [120.0]	0.73 [18.5]	2.87 [73.0]	0.50 [12.7]	1.66 [42.2]	0.39 [10.0]	N/A	1.22 [31.0]	2.362±0.005 [60.0±0.13]	1.181 [30.0]	1.06 [27.0]	1.000-8 UNC GRADE 5 [M24 8.8]	515 FT LBS [700Nm]

# ADVANTAGE LINE - HIGH CAPACITY LOW PROFILE

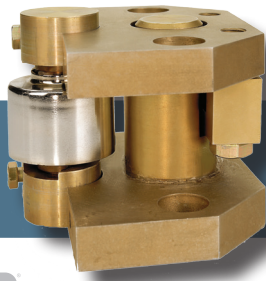

## HI LPRA Hermetic Load Point Assembly Compression

The Hardy HI LPRA ADVANTAGE® Series, Low Profile, rocker load point systems are designed for use on high capacity vessels.

Each load point consists of mounting hardware and a stainless steel mV/V, mV/V/ohm matched, short rocker type load sensor with true hermetic sealing, C2® Electronic Calibration capabilities, on-board electronic certs, a ¼ NPT conduit adapter and thirty feet of cable. Each low profile rocker load point system provides built-in checking, lift-off protection and is specifically designed to eliminate the effects of unwanted forces to provide the highest possible accuracy. A grounding strap, fixed color code wiring label and installation manual are provided with each load point. The mounting hardware is available in either stainless or zinc plated steel. The sensors have an IP rating of IP68/IP69K and are NTEP Class III.

The HI LPRA short rocker load point assembly is available in the following standard capacities: 33K lbs and 50K lbs. They, along with the HI LPRC03, are replacements for the HI LPD series load point line.

### SPECIFICATIONS

Rated Output (ES)	2 ± 0.002 mV/V
Non-Linearity	< ± 0.012 % R.O.
Hysteresis	< ± 0.025 % R.O.
Zero Balance	< ± 1.0 % R.O.
Creep @ 5 Min.	< ± 0.010 % R.O.
Temp Effect Output	< ± 0.0014 % R.O./C
Temp Effect Sensitivity	< ± 0.0005 % R.O./C
Input Resistance	1150 ± 50 ohm
Output Resistance	1000 ± 10 ohm
Insulation Resistance	> 5000 Mohm
Excitation	5 - 15 vdc
Safe Load Limit	200 % Emax
Ultimate Load	300 % Emax
Safe Side Load LC	100% Emax
Safe Side Load LP	16.86 Klbs
Max Lift Off	16.86 Klbs
Warranty	Two years

### ORDERING INFORMATION

Load Point can be ordered with zinc plated Hardware (-45C) as shown, or optional Stainless Hardware (-43C)

Shipping Weight approx 30 lbs. for Load Point, 4 lbs. for Sensors.

Capacity		Model #	Model#
lbs	mt	FIXED Assy	SPARE Load Sensor
33K	15	HI LPRA33K- 45C	HI RCH04-33K
50K	23	HI LPRA50K- 45C	HI RCH04-50K

Load points can be ordered as a system rather than ordering individual components.

#### 3 POINT SYSTEMS

CAPACITY		MODEL#
lbs	mt	
99k	45	HI 3R99K-45
150K	69	HI 3R150K-45

#### 4 POINT SYSTEMS

CAPACITY		MODEL#
lbs	mt	
132K	60	HI 4R132K-45
200K	91	HI 4R200K-45

## ADVANTAGE Load Point Outline

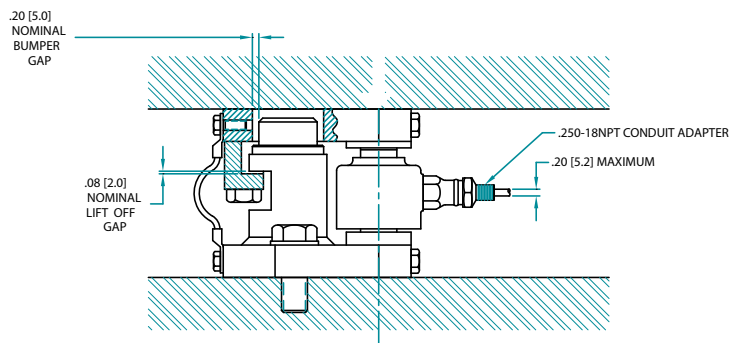
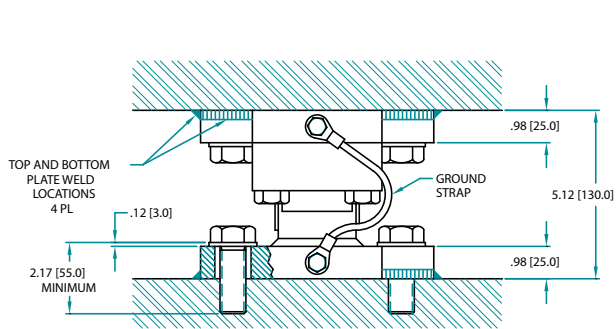

### HI LPR Series

C2 WIRE COLOR CODE FLAG LABEL IS FOUND APPROX. 10 IN. FROM END OF SENSOR'S CABLE

EXCITATION +	RED
EXCITATION -	BLACK
SIGNAL +	GREEN
SIGNAL -	WHITE
C2+	GRAY
C2 -	VIOLET
SHIELD	YELLOW

WARNING: NEVER cut load sensor cable

CABLE LENGTH 30 FEET

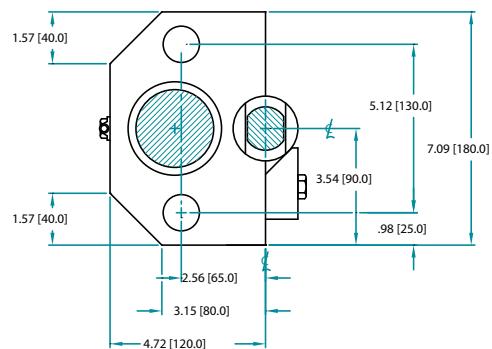

## ADVANTAGE Load Sensor Outline

### HI RCH04 Series

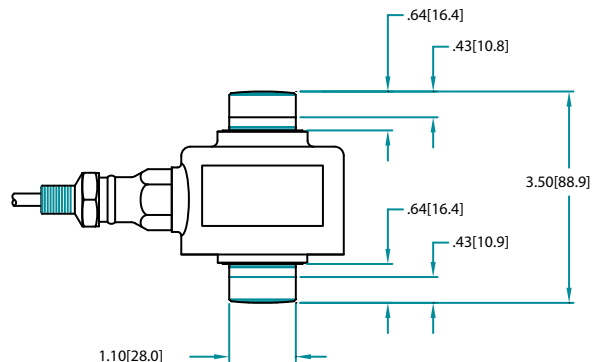
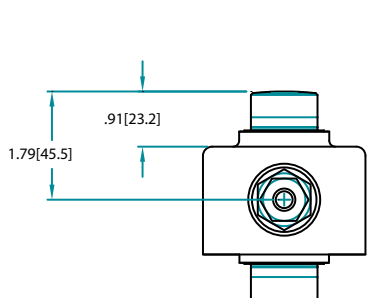
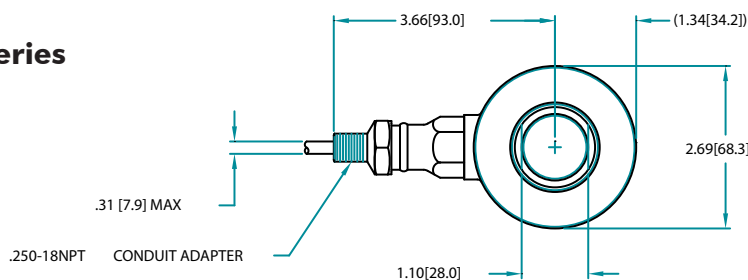

# ADVANTAGE LINE - HIGH CAPACITY LOW PROFILE

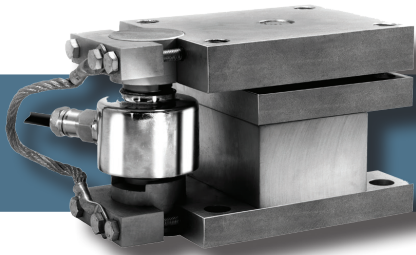

## HI LPRC03 Hermetic Load Point Assembly Compression

The Hardy HI LPRC03 ADVANTAGE® Series, Low Profile, rocker load point systems are specially designed for high capacity hopper and tank weighing. They are easy to install by bolting or welding, have a lower profile, and provide more lift off protection than previous designs.

Each rocker load point consists of either plated or stainless steel mounting hardware and a stainless steel mV/V & mV/V/ohm matched load sensor with true IP68 hermetic sealing, Hardy's exclusive C2® calibration, a ¼ NPT conduit adapter and 30 feet of cable for 110K and less and 50 feet of cable for 220K and above. Each assembly provides built-in checking, lift off protection and is specifically designed to eliminate the effects of unwanted forces to provide exceptional accuracy. A grounding strap, fixed color code wiring label and installation manual are provided with each load point. The mounting hardware is available in either stainless or zinc plated or cast steel. The sensors have an IP rating of IP68/IP69K and are NTEP Class III.

The HI LPRC03 rocker load point assembly is available in the following standard capacities: 66K, 88K, 110K, 220K, 330K and 660K lbs.

### SPECIFICATIONS

Rated Output (ES)	2±0.002mV/V
Non-Linearity	< ±0.012 % R.O.
Hysteresis	< ±0.025 % R.O.
Zero Balance	< ±1.0 % R.O.
Creep @ 5 Min.	< ±0.010 % R.O.
Temp Effect Output	< ±0.0014 % R.O./C
Temp Effect Sensitivity	< ±0.0005 % R.O./C
Input Resistance	1150 ± 50 ohm
Output Resistance	1000 ± 10 ohm
Insulation Resistance	>5000 Mohm
Excitation	5 - 15 vdc
Safe Load Limit	200 % Emax
Ultimate Load	300 % Emax
Safe Side Load LC	100% Emax
Max Lift Off*	40.4Klbs (66K-88K cap) 67.4Klbs (110K-120K cap) 89.9Klbs (330K cap) 134.9Klbs (660K cap)
Warranty	Two years

### ORDERING INFORMATION

Load Point can be ordererd with Stainless Hardware (-43C) as shown ,or zinc plated or cast steel Hardware for 66K - 88K (-45C), or painted steel for 110K and over (-41C)  
Shipping Weight for Load Point approx. 30-565 lbs., Sensor 4 - 60 lbs.

Capacity		Model #	Model#
lbs	mt	FIXED Assy	SPARE Load Sensor
66K	30	HI LPRC03-66K-43C	HIRCH03-66K
88K	40	HI LPRC03-88K-43C	HIRCH03-88K
110K	50	HI LPRC03-110K-43C	HIRCH03-110K
220K	100	HI LPRC03-220K-43C	HIRCH03-220K
330K	150	HI LPRC03-330K-43C	HIRCH03-330K
660K	300	HI LPRC03-660K-43C	HIRCH03-660K

Load points can be ordered as a system rather than ordering individual components.

### 3 POINT SYSTEMS

CAPACITY		MODEL#
lbs	mt	
198K	90	HI 3RA198K-43
264K	120	HI 3RA264K-43
330K	150	HI 3RA330K-43
660K	300	HI 3RA660K-43
990K	450	HI 3RA990K-43
1980K	900	HI 3RA1980K-43

### 4 POINT SYSTEMS

CAPACITY		MODEL#
lbs	mt	
264K	120	HI 4RA264K-43
352K	160	HI 4RA352K-43
440K	200	HI 4RA440K-43
880K	400	HI 4RA880K-43
1320K	600	HI 4RA1320K-43
2640K	1200	HI 4RA2640K-43



## ADVANTAGE Load Point Outline

**HI LPRC03 Series**  
**66K lbs - 88K lbs**  
 Other sizes available on website

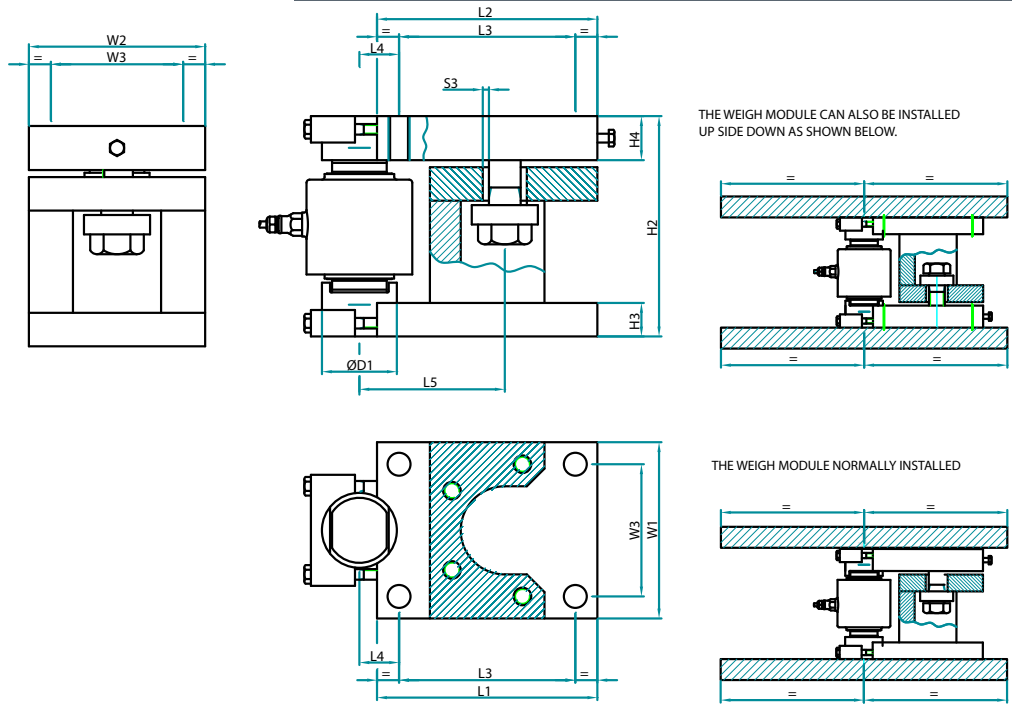

C2 WIRE COLOR CODE FLAG LABEL IS FOUND APPROX. 10 IN. FROM END OF SENSOR'S CABLE

EXCITATION +	RED
EXCITATION -	BLACK
SIGNAL +	GREEN
SIGNAL -	WHITE
C2+	GRAY
C2 -	VIOLET
SHIELD	YELLOW

WARNING: NEVER cut load sensor cable

CABLE LENGTH: 30 FEET OF CABLE FOR 110K AND LESS, AND 50 FEET OF CABLE FOR 220K

Load cell type/capacity	D1	D2	H2	H3	H4	L1	L2	L3	L4	L5	W1	W2	W3	S3	T2	Max lift off force Klbs	Max side force Klbs	Weight excl. loadcell Lbs
HIRCH03-66K & 88K	60	22	200	29	40	210	210	170	30	125	150	150	110	6	M20	40.4	20.2	73
HIRCH03-110K & 220K	85	26	250	38	50	250	250	200	45	165	200	200	150	7	M24	67.4	33.7	144

Load cell type/capacity	D1	D2	H2	H3	H4	L1	L2	L3	L4	L5	W1	W2	W3	S3	T2	Max lift off force Klbs	Max side force Klbs	Weight excl. loadcell Lbs
HIRCH03-330K	110	33	300	40	60	300	290	230	60	205	260	250	190	8	M30	89.9	44.9	250
HIRCH03-660K	135	39	400	60	70	370	350	280	65	235	320	300	230	10	M36	179.8	67.4	497

## ADVANTAGE Load Sensor Outline

**HI RCH03 Series**  
**66K lbs - 110K lbs**  
 Other sizes available on website

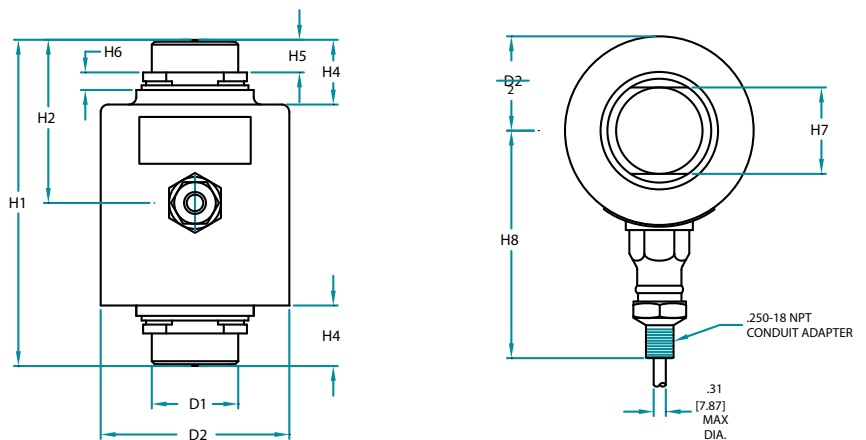
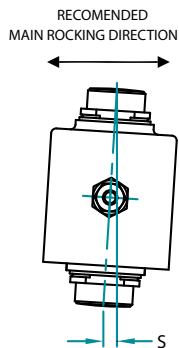

DIMENSIONS- INCHES & [mm]

TOLERANCES: ±0.015 [0.4] UNLESS OTHERWISE STATED

MODEL	CAPACITY LBS [T]	H1	H2	H3	H4	H5	H6	H7	H8	ØD1	ØD2	R	S MAX*	RF **
HI RCH03	66K [30]	5.50 [139.8]	2.75 [69.9]	1.02 [26.0]	1.10 [28.0]	0.55 [14.0]	0.217 [5.5]	1.54 [39.0]	3.88 [98.5]	1.54 [39.0]	3.19 [81.0]	N/A	0.394 [10.0]	7055 LBS [3200Kg]
	110K [50]	7.00 [178.0]	3.50 [89.0]	1.26 [32.0]	1.34 [34.0]	0.67 [17.0]	0.335 [8.5]	1.73 [44.0]	4.28 [108.7]	1.73 [44.0]	3.90 [99.0]	N/A	0.630 [16.0]	11,023 LBS [5000Kg]

# ADVANTAGE LINE - LOW TO HIGH CAPACITY

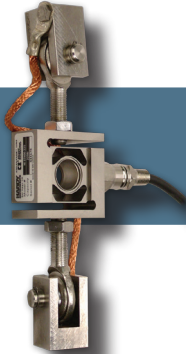

## HI HLPT Hermetic Load Point Assembly Tension

The Hardy HI HLPT ADVANTAGE® Series, tension load point systems are designed for use on low to medium capacity vessels.

Each load point consists of mounting hardware and a stainless steel mV/V and mV/V/ohm matched load sensor with true hermetic sealing, C2® Electronic Calibration capabilities, on-board electronic certs, a ¼ NPT conduit adapter and twenty feet of cable. Each load point assembly is specifically designed to eliminate the effects of unwanted forces to provide exceptional accuracy. A grounding strap and fixed color code wiring label are provided with each load point. The mounting hardware is available in either stainless or zinc plated steel for capacities up to 4.5K pounds and galvanized steel in higher capacities. The load sensors have an IP rating of IP68/IP69K and are NTEP Class III.

The HI HLPT is available in the following standard capacities: 225 lbs, 450 lbs, 1,125 lbs, 2.25K lbs, 4.5K lbs and 11.25K lbs.

### SPECIFICATIONS

Rated Output (ES)	2 ± 0.002mV/V
Non-Linearity	< ± 0.018 % R.O.
Hysteresis	< ± 0.025 % R.O.
Zero Balance	< ± 1.0 % R.O.
Creep @ 5 Min.	< ± 0.010 % R.O.
Temp Effect Output	< ± 0.0014 % R.O./C
Temp Effect Sensitivity	< ± 0.0007 % R.O./C
Input Resistance	1106 ± 5 ohm
Output Resistance	1000 ± 1 ohm
Insulation Resistance	> 5000 Mohm
Excitation	5 - 15 vdc
Safe Load Limit	200 % Emax
Ultimate Load	300 % Emax
Warranty	Two years

### ORDERING INFORMATION

Load Point can be ordererd with Stainless Hardware (43C) as shown, or zinc plated Hardware (-45C)

Shipping Weight for Load Point approx. 10-35 lbs, Sensor 4 lbs.

Capacity		Model #		Model#
lbs	mt	FIXED Assy	SPARE Load Sensor	
225	0.1	HI HLPT225-43C	HI STH06-225	
450	0.2	HI HLPT450-43C	HI STH06-450	
1,125	0.5	HI HLPT1125-43C	HI STH01-1125	
2.25K	1	HI HLPT2.25K-43C	HI STH01-2.25K	
4.5K	2	HI HLPT4.5K-43C	HI STH01-4.5K	
11.25K	5	HI HLPT11.25K-43C	HI STH01-11.25K	

Load points can be ordered as a system rather than ordering individual components.

### 3 POINT SYSTEMS

CAPACITY		MODEL#
lbs	mt	
675	0.3	HI 3T675-43
1.35K	0.6	HI 3T1.35K-43
3.375K	1.5	HI 3T3.375K-43
6.75K	3.1	HI 3T6.75K-43
13.5K	6.1	HI 3T13.5K-43
33.75	15.3	HI 3T33.75K-45

### 4 POINT SYSTEMS

CAPACITY		MODEL#
lbs	mt	
900	0.5	HI 4T900-43
1.8K	0.8	HI 4T1.8K-43
4.5K	2.0	HI 4T4.5K-43
9K	4.1	HI 4T9K-43
18K	8.2	HI 4T18K-43
45K	20.4	HI 4T45K-45

## ADVANTAGE Load Point Outline

### HI HLPT Series

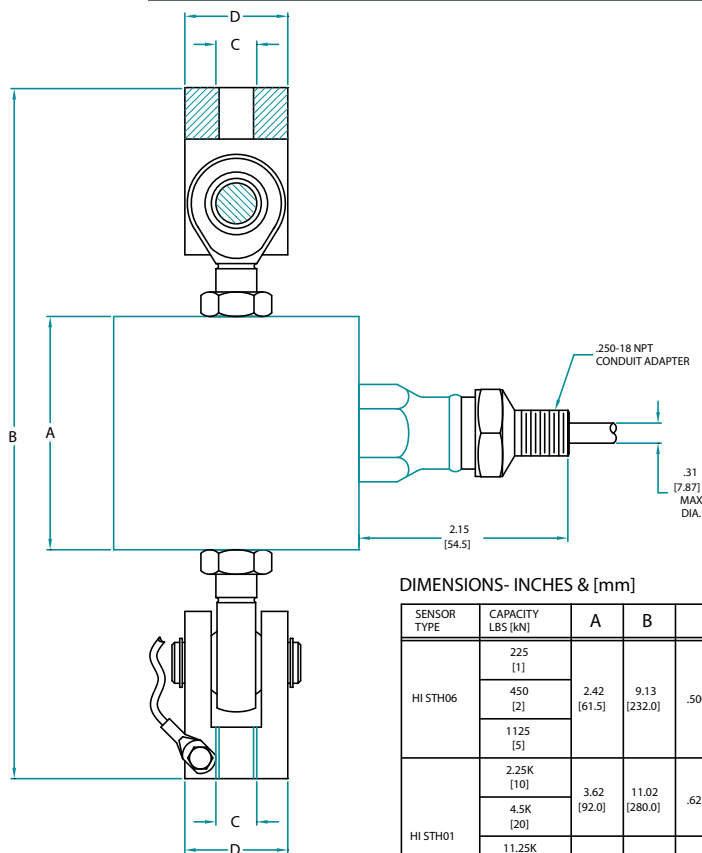

DIMENSIONS- INCHES & [mm]

SENSOR TYPE	CAPACITY LBS [kN]	A	B	C	D
HI STH06	225 [1]	2.42 [61.5]	9.13 [232.0]	.500-13 UNC	1.38 [35.0]
	450 [2]				
	1125 [5]				
HI STH01	2.25K [10]	3.62 [92.0]	11.02 [280.0]	.625-11 UNC	1.77 [45.0]
	4.5K [20]				
	11.25K [50]	5.35 [136.0]	14.96 [380.0]	1.000-8 UNC	2.36 [60.0]

C2 WIRE COLOR CODE FLAG LABEL IS FOUND APPROX. 10 IN. FROM END OF SENSOR'S CABLE

EXCITATION +	RED
EXCITATION -	BLACK
SIGNAL +	GREEN
SIGNAL -	WHITE
C2+	GRAY
C2 -	VIOLET
SHIELD	YELLOW

WARNING: NEVER cut load sensor cable

CABLE LENGTH: 20 FEET

## ADVANTAGE Load Sensor Outline

### HI STH06 Series

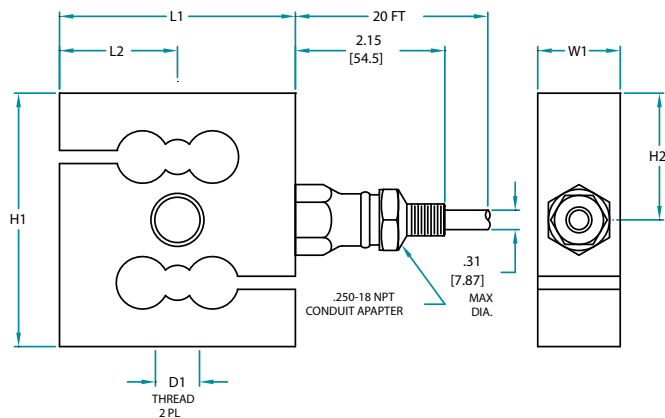

DIMENSIONS- INCHES & [mm]

CAPACITY LBS [kN]	H1	H2	L1	L2	W1	D1 THREAD
225 [1] 450 [2] 1125 [5]	2.42 [61.5]	1.21 [30.7]	2.42 [61.5]	1.21 [30.7]	1.18 [30.0]	.500-20 UNF
2.25K [10] 4.5K [20]	3.62 [92.0]	1.81 [46.0]	3.38 [86.0]	1.69 [43.0]	1.18 [30.0]	.625-18 UNF
11.25K [50]	5.35 [136.0]	2.86 [68.0]	5.62 [143.0]	2.81 [71.5]	1.69 [43.0]	1-12 UNF

TOLERANCES: ±0.015 [0.4] UNLESS OTHERWISE STATED

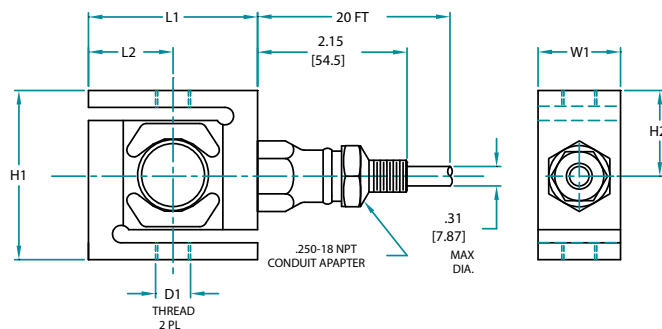

### HI STH01 Series

# ADVANTAGE Lite

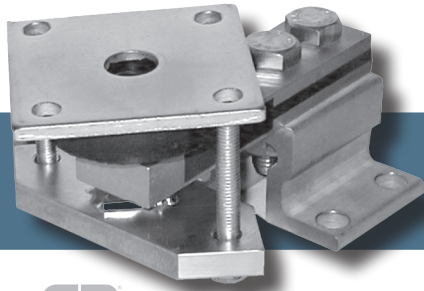

## HI LPRE Load Point Assembly Compression

The Hardy ADVANTAGE® Lite Series of load point assemblies provides superior performance when compared to common load cells, as well as exceptional value, in meeting your weighing needs.

Each pre-assembled load point consists of rugged stainless steel mounting hardware and a C2® Calibration compatible stainless steel, mV/V and mV/V/ohm matched and sealed load sensor. The rubber element mount provides stray voltage isolation, minor misalignment correction, thermal expansion and shock absorption. It can be used in applications with conveyors and vessels with or without agitators or mixers. The load point assembly is self-checking, eliminating the need for costly external check rods to hold the assembly in place and also provides lift-off protection. Each load sensor comes with twenty feet of six-conductor cable and a color-coded wiring label to aid in installation. The sensors have an IP rating of IP67 and are NTEP Class III certified. The ADVANTAGE Lite Series is available in the following standard capacities: 440 lb, 1,100 lb, 2,200 lb, and 4,400 lb.

### SPECIFICATIONS

Rated Output (ES)	2±0.004mV/V
Non-Linearity	< ±0.025 % R.O.
Hysteresis	< ±0.025 % R.O.
Zero Balance	< ±1.0 % R.O.
Creep @ 5 Min.	< ±0.010 % R.O.
Temp Effect Output	< ±0.002 % R.O./C
Temp Effect Sensitivity	< ±0.002 % R.O./C
Input Resistance	1100 ± 5.0% ohm
Output Resistance	1000 ± 2.0% ohm
Insulation Resistance	>5000 Mohm
Excitation	5 - 15 vdc
Safe Load Limit	200 % Emax
Ultimate Load	300 % Emax
Warranty	Two years

Calibrated for mV/V/Ohm and mV/V, which results in "cornering" without adjustment, may eliminate the need for re-calibration after field replacement.

### ORDERING INFORMATION

Only available with Stainless Hardware

Shipping weight for Load Point approx 5 lbs, Sensor 3 lbs.

Capacity		Model#	
lbs	kg	SPARE Load Sensor	Rubber Element Assembly
440	220	HI SB02-440	HI LPRE 440-33C
1100	500	HI SB02-1.1K	HI LPRE 1.1K-33C
2200	1000	HI SB02-2.2K	HI LPRE 2.2K-33C
4400	2000	HI SB02-4.4K	HI LPRE 4.4K-33C

Load points are ordered only as individual components.

## ADVANTAGE Lite Load Point Outline

**HI LPRE Series**  
**440 Lbs/220 kgs**  
 Other sizes available  
 on website

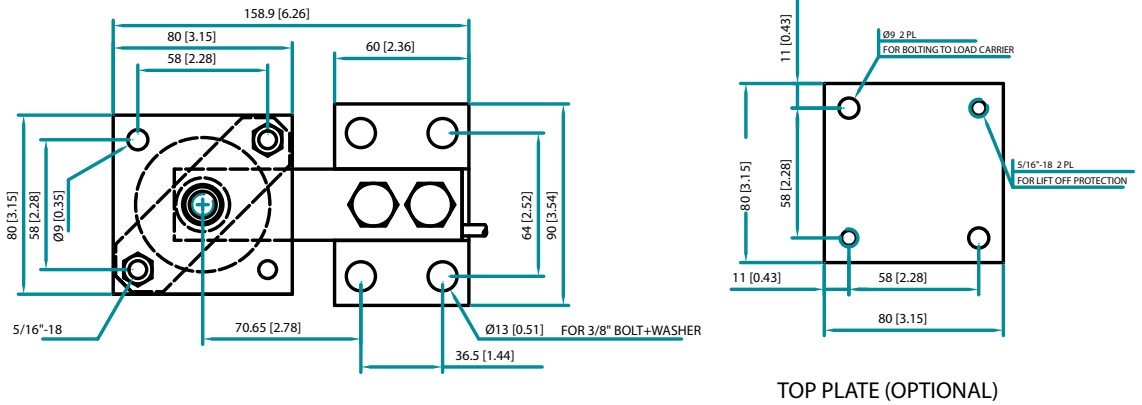

C2 WIRE COLOR CODE FLAG LABEL IS FOUND  
 APPROX. 10 IN. FROM END OF SENSOR'S CABLE

EXCITATION +	RED
EXCITATION -	BLACK
SIGNAL +	GREEN
SIGNAL -	WHITE
C2+	GRAY
C2 -	VIOLET
SHIELD	YELLOW

WARNING: NEVER cut load sensor cable

CABLE LENGTH: 20 FEET

## HI SB02 Series

DIMENSIONS- INCHES & [mm]

CAPACITY LBS [KG]	H1	H2	ØD1	ØD2
440 [200]	0.50 [12.7]	0.25 [6.3]	0.405±0.003 [10.26±.06]	
1.1k [500]	0.63 [15.9]	0.43 [10.9]	0.405±0.003 [10.26±.06]	0.712±0.003 [18.06±.06]
2.2k [1000]	0.75 [19.1]	0.24 [6.0]	0.562±0.003 [14.26±.06]	
4.4k [2000]	1.00 [25.4]	0.26 [6.5]	0.688±0.003 [17.46±0.06]	0.909±0.003 [23.06±0.06]

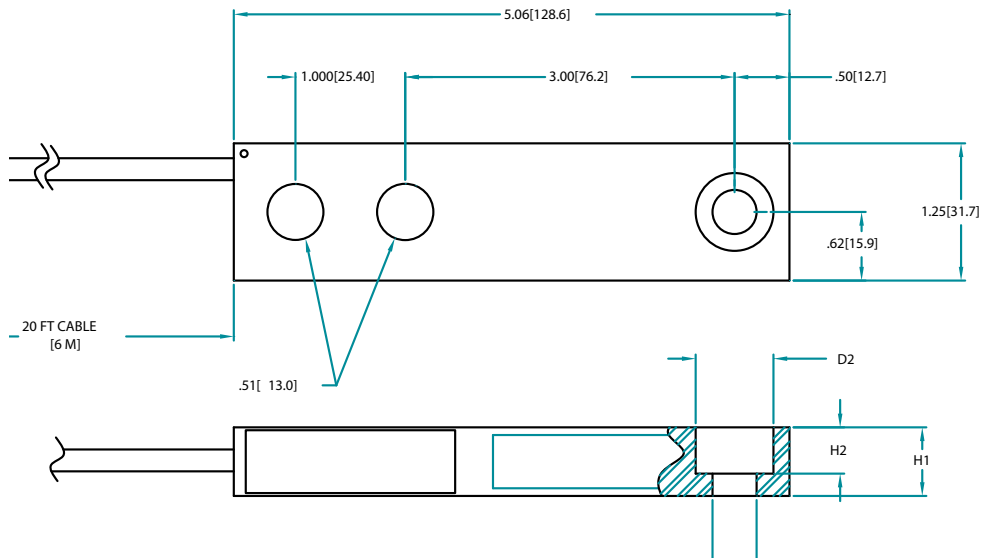

## ADVANTAGE Lite Load Sensor Outline

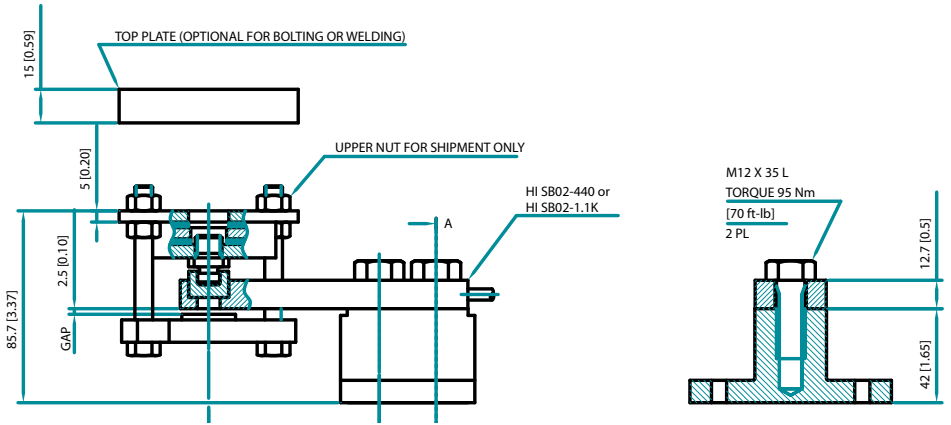

# JUNCTION BOX and CABLE



## Load Point Junction Boxes with Integrated Technician®



The Hardy's C2® certified Junction Box contains circuitry in a waterproof enclosure which distributes the excitation voltage to up to four load points and transfers each load point's performance characteristics and weight signals to the weight controller. The junction box, without being opened, allows an instrument operator to switch in an internal test circuit to test the stability of the cable from the junction box to the Integrated Technician "IT" equipped weighing instrument as well as the instrument. In addition, individual load sensors can be isolated for weight and voltage readings all from the weighing instrument's front panel.

The box's unique removable multiple connector design allows for easy isolation and troubleshooting of non-"IT" capable weighing systems. Two junction boxes can be cabled together to handle up to eight load points from a single scale. All are available in NEMA 4 rated painted steel, NEMA 4X rated stainless steel or fiberglass, each box comes with two packaged hole plugs and five cable grip fittings suitable for O.D. cable of 1/4 to 3/8 inches. A label is provided on the underside of the top cover to record load point positions. A non-IT version with trim pots is also available.

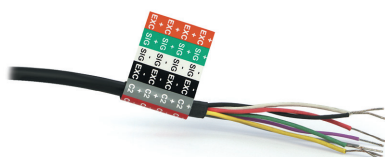

## Cable

The Hardy C2 certified load point cable is designed to easily handle the low voltages found in weighing systems, as well as the load point's performance characteristics and switching commands. Eight conductors carry the signals to and from the weight controller and the junction box. Each conductor is 22 AWG stranded copper wire for flexibility. The cable has a braided tinned copper shield and a mylar barrier tape wrap. The outer jacket is vinyl and 0.060" thick with an 0.40" outside diameter.

### ORDERING INFORMATION

Shipping Weight for cable approx. 1lb. per 10". Junction box approx. 6 lbs.

MODEL #	DESCRIPTION
HI 215IT-SS1	Stainless Steel Standard
HI 215IT-SS2*	Stainless with Trim Pots
HI 215IT-PS1	Painted Standard
HI 215IT-PS2*	Painted with Trim Pots
HI 215IT-FG1	Fiberglass Standard
HI 215IT-FG2*	Fiberglass with Trim Pots
HI 215IT-SC	Summing Card, no enclosure
HI 215IT-SCT*	Summing Card with Trim Pots, no enclosure
<b>CABLE</b>	
C2 Cable	C2 Certified, 8-Conductor

\*Not for use with C2 Load Points

## Junction Box Field Wiring

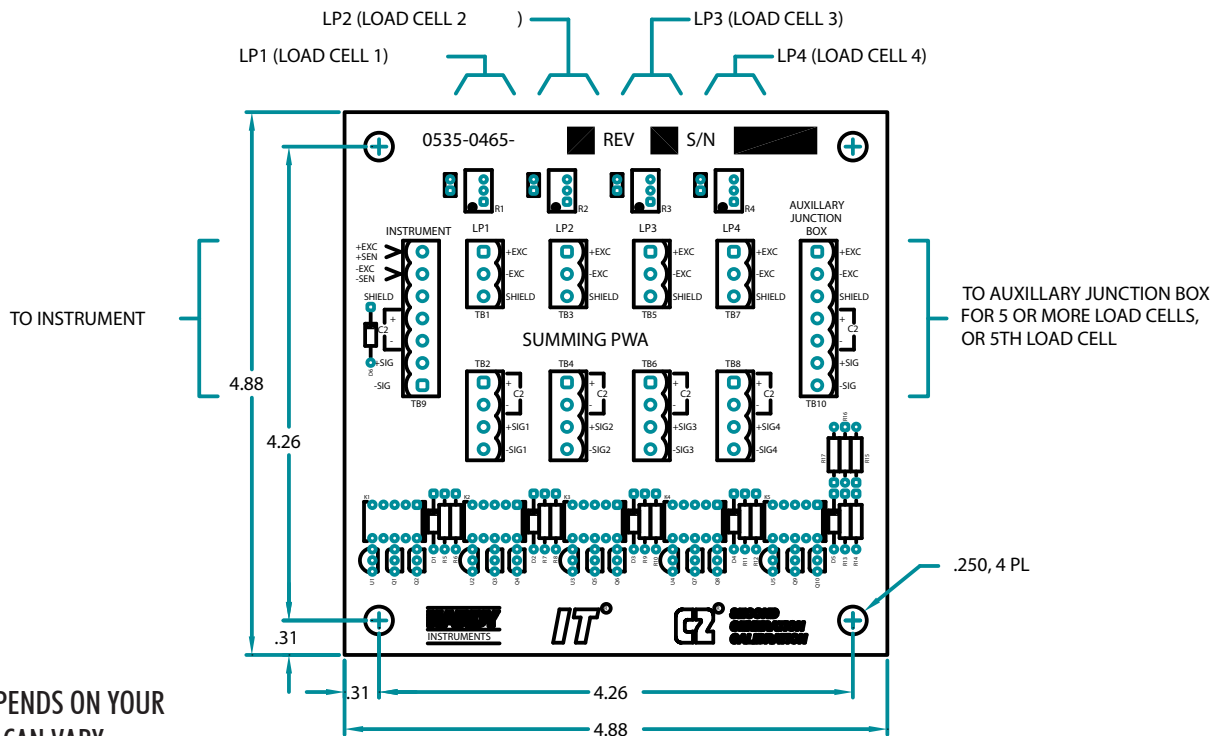

WIRE COLOR CODE DEPENDS ON YOUR LOAD SENSOR COLOR, CAN VARY FROM MODEL TO MODEL.

## Junction Box Enclosures

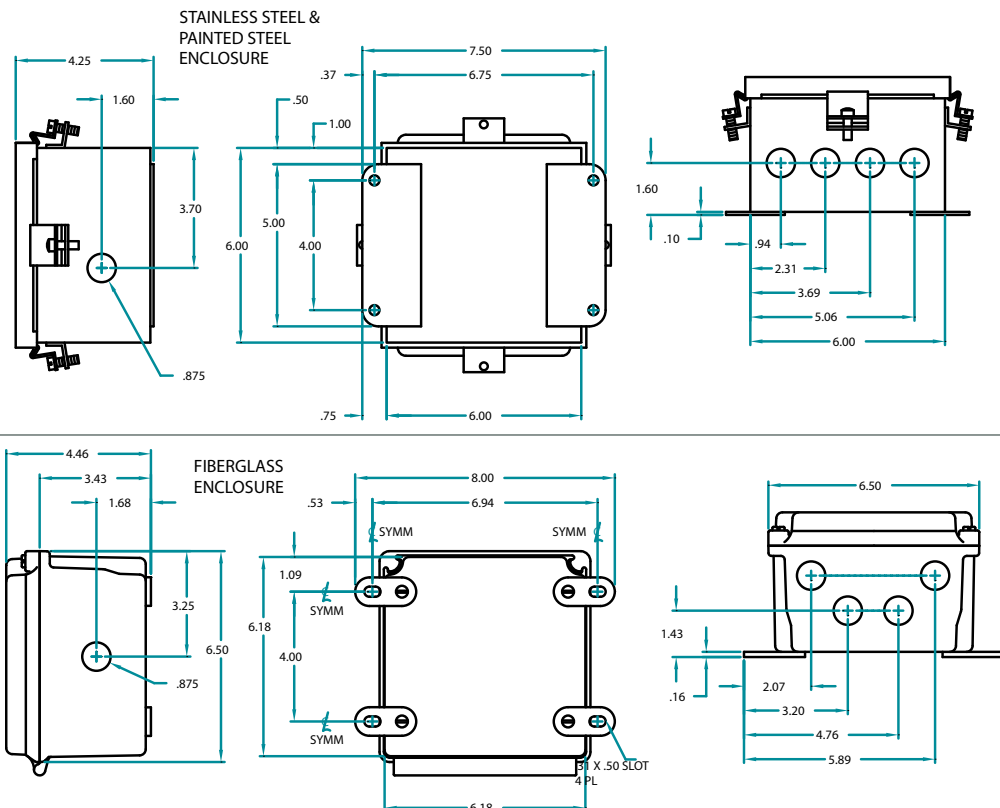

# ANY-WEIGH BENCH SCALES



## ANY-WEIGH® Bench Scales



The ANY-WEIGH® Bench scales provide complete flexibility in size and capacity for use in a wide range of weighing applications. With their rugged construction and stainless steel tops, ANY-WEIGH Scales are a great fit for both laboratory and industrial installations.

The ANY-WEIGH line of bench scales can be configured with standard interfacing to a weight instrument or with a built-in, direct connection to a PLC or PC.

### UNIVERSAL SCALE SPECIFICATIONS

Rated Output (ES)	0.900 ± 0.0009mV/V
Combined Error	0.030 % R.O.
Zero Balance	5.0 % R.O.
Creep @ 30 Min.	0.030 % R.O.
Temp Effect Output	< ± 0.0015 % R.O./°F
Temp Effect Sensitivity	< ± 0.0008 % R.O./°F
Comp. Temp Range	-10 - +40°C
Oper. Temp Range	-10 - +65°C
Input Resistance	297.5 ± 10% ohm
Output Resistance	250 ± 5% ohm
Excitation	5 - 15 Volts
Safe Load Limit	300 % Emax
Ultimate Load	400 % Emax
Max Cornering Error	0.06% 1/2 full scale load, 1/2 way to corner
Warranty	Two years

### Universal Scale - HI xxxxSBU-x\*

Directly attach the scale's 15-foot cable to any weighing instrument or controller. If interfacing with a Hardy Controller, you can take full advantage of WEVERSAVER®, and C2® Electronic Calibration.

### DeviceNet Scale - HI xxxxSBD-x\*

With its built-in DeviceNet interface you can use this scale to provide a weight output to any point on a DeviceNet Network. This version also incorporates both the WEVERSAVER and C2 technologies, and comes with a six-inch pig-tailed connector.

### Analog Scale - HI xxxxSBA-x\*

Use the Analog Output Scale to provide a 4-20 mA output directly proportional to the weight reading. This version offers a low-cost, effective solution for bringing an analog weight reading directly into a control system, with minimal additional wiring or hardware, and comes with a 15-foot 2-wire shielded cable. The scale comes pre-wired and pre-calibrated from the factory but provides potentiometers for coarse and fine zero adjustment as well as span. It does not have C2 or WEVERSAVER capabilities.

### Analog Hazardous Scale - HI xxxxSBAFM-x\*

The HI SBAFM Series of bench scales come with a built-in strain gauge transmitter providing a 4-20mA output proportional to the weight reading directly to a control system. These scales are Intrinsically safe for use in Class I, II, Div 1, Groups A, B, C, D, E, F and G, T4. The HI SBAFM comes with a 15-foot two wire shielded cable which carries DC power to the scale and the weight signal from it. The scale comes pre-wired and pre-calibrated from the factory but provides potentiometers for coarse and fine zero adjustment as well as span. It does not have C2 or WEVERSAVER capabilities.

### ORDERING INFORMATION

MODEL #	SIZE	CAPACITY	HEIGHT	SHIP WEIGHT
	in/mm	lb/kg	in/mm	lb/kg
HI 1212SB__-33	12" x 12" / 298 x 298	33/15	1.54/39.1	14/6.4
HI 1212SB__-66	12" x 12" / 298 x 298	66/30	1.56/39.6	14/6.4
HI 1212SB__-130	12" x 12" / 298 x 298	130/60	1.62/41.2	14/6.4
HI 2424SB__-130	24" x 24" / 600 x 600	130/60	1.62/41.2	52/23.6
HI 2424SB__-330	24" x 24" / 600 x 600	330/150	1.65/41.9	52/23.6
HI 2424SB__-660	24" x 24" / 600 x 600	660/300	1.87/47.5	52/23.6
HI 2424SB__-1.3K	24" x 24" / 600 x 600	1300/590	2.05/52.1	

SBU Universal      SBD Devicenet  
SBA Analog        SAFM Analog Hazardous

All information and drawings on these pages are subject to change without notice. Consult website for latest specifications.



## ANY-WEIGH Bench Scale Outline

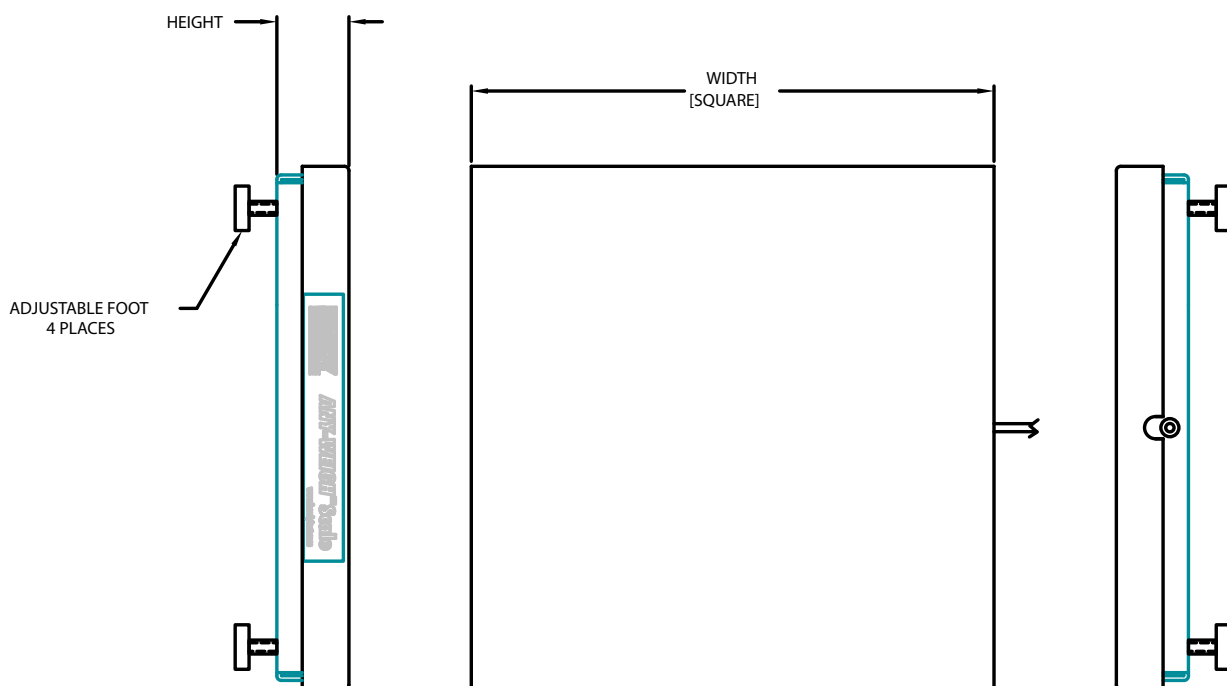

## Additional Specs

DEVICENET OUT SPECIFICATIONS		ANALOG OUT SPECIFICATIONS	
Resolution	20 bit	Loop Power	15-50VDC across scale. A 15V min. would be with 0 ohm load; add 20mV/ohm to the min. loop voltage. A 500 ohm load would require 25V min. loop voltage.
Update Rate	10 or 55 per second	Linearity	0.11% of full scale
Averages	0-255 selectable	Response Time	250 milliseconds
Temp Coefficient	<0.0023%/°C	Temp Range	0 - 60°C
Input Power	11-25 VDC	Temp Coefficient	0.025%/°C
Type	Generic		
I/O Slave Message	Polling		
Baud Rates	125K, 250K, 500K		
Inputs	Gross, Net, Tare		
Outputs	Weight: Metric/Engl, Zero & Tare, WAVERSAVER, Calib. type, Span Weight (Hard Cal), Cal Low Value, Cal High Value, # of Averages		

\* depending on WAVERSAVER settings

HAZARDOUS ANALOG SPECIFICATIONS	
Linearity	0.11% of full scale
Certifications	Class I, II, Div 1, Groups A, B, C, D, E, F and G, T4

\*\* Some barrier protection is required for the Analog Hazardous scale when located in a hazardous area.

# ANY-WEIGH FLOOR SCALES

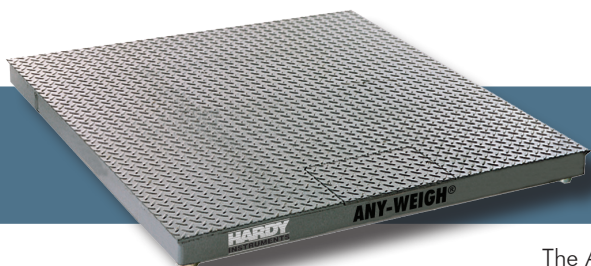

## ANY-WEIGH® Floor Scales



The ANY-WEIGH line floor scales are designed and built for harsh chemical and washdown industrial environments, yet are easy to use and install with the latest advancements in weighing technology. Gone are the manual multi-turn potentiometers for corner adjusting. Just level the deck, attach the included 20-foot cable, calibrate (if a C2® compatible instrument, set your reference), and begin weighing.

Each scale has built-in INTEGRATED TECHNICIAN® circuitry. When coupled with a Hardy controller, the scale provides diagnostic and troubleshooting tools that read individual weights and voltages to aid you in isolating problems and ensure the integrity of your scale system.

All ANY-WEIGH floor scales come with Hardy ADVANTAGE® stainless steel, true hermetically-sealed sensors - sealed at both the gauging area and cable entry for long life. All are matched and calibrated for mV/V and mV/V/ohm. Instead of the typical threaded hole into which the load cell foot is attached, the ANYWEIGH sensors use a blind hole technique ensuring the load is applied at a precise location, providing an accurate reading, weightment after weightment.

With a deck height of only three inches and 100% end loading, these floor scales enable easy, any-side access and maneuvering of all types of load handling equipment onto the scale. Each scale features a field-proven, rugged structural rib design with 1/4 inch thick smooth or diamond plate deck that can withstand overloads of up to 150% of its capacity. A durable rubber-based foot for each load sensor is height adjustable from below the platform.

### FLOOR SCALE SPECIFICATIONS

Platform	0.25 inch thick smooth or safety tread deck
Height	3 inches (adjustable 0.275" 7mm)
Overload Capacity	150% of rated scale capacity
End Loading	100% of rated scale capacity
Construction	Stainless Steel - Type 304 Mild Steel - Type A36 carbon steel coated with two part enamel
Paint	Epoxy modified alkyd enamel (mild steel models only)
Load Sensor	C2® stainless steel, hermetic seal, blind hold loading
Junction Box	NEMA 4x stainless steel
Summing Card	Individual load sensor terminal blocks; INTEGRATED TECHNICIAN® circuitry
Scale Excitation	5vdc +/-5%
Warranty	Two years

### ORDERING INFORMATION

MODEL #	SIZE	CAPACITY	HEIGHT	SHIP WEIGHT
	feet/cm	lb/kg	in/cm	lb/kg
HI AFSU303001-4XX	30" x 30" / 76 x 76	1000/454	3"/1.19 cm	200/91
HI AFSU3301-4XX	3' x 3' / 91 x 91	1000/454	3"/1.19 cm	250/113
HI AFSU3302-4XX	3' x 3' / 91 x 91	2500/1134	3"/1.19 cm	250/113
HI AFSU4402-4XX	4' x 4' / 122 x 122	2500/1134	3"/1.19 cm	405/184
HI AFSU4405-4XX	4' x 4' / 122 x 122	5000/2268	3"/1.19 cm	405/184
HI AFSU4410-4XX	4' x 4' / 122 x 122	10,000/4536	3"/1.19 cm	405/184
HI AFSU4505-4XX	4' x 5' / 122 x 152	5000/2268	3"/1.19 cm	500/227
HI AFSU4510-4XX	4' x 5' / 122 x 152	10,000/4536	3"/1.19 cm	500/227
HI AFSU4605-4XX	4' x 6' / 122 x 183	5000/2268	3"/1.19 cm	600/272
HI AFSU4610-4XX	4' x 6' / 122 x 183	10,000/4536	3"/1.19 cm	600/272
HI AFSU5505-4XX	5' x 5' / 152 x 152	5000/2268	3"/1.19 cm	650/295
HI AFSU5510-4XX	5' x 5' / 152 x 152	10,000/4536	3"/1.19 cm	650/295
HI AFSU5705-4XX	5' x 7' / 152 x 213	5000/2268	3"/1.19 cm	900/408
HI AFSU5710-4XX	5' x 7' / 152 x 213	10,000/4500	3"/1.19 cm	900/408
HI AFSU6810-4XX	6' x 8' / 183 x 244	10,000/4500	3"/1.19 cm	1150/522

-4XX Stainless Hermetic Load Cells  
-X1X Painted Platform Top  
-X3X Stainless Platform Top

-XXS Smooth Platform Top  
-XXT Tread Plate Platform top

All information and drawings on these pages are subject to change without notice. Consult website for latest specifications.

## ANY-WEIGH Floor Scale Outline

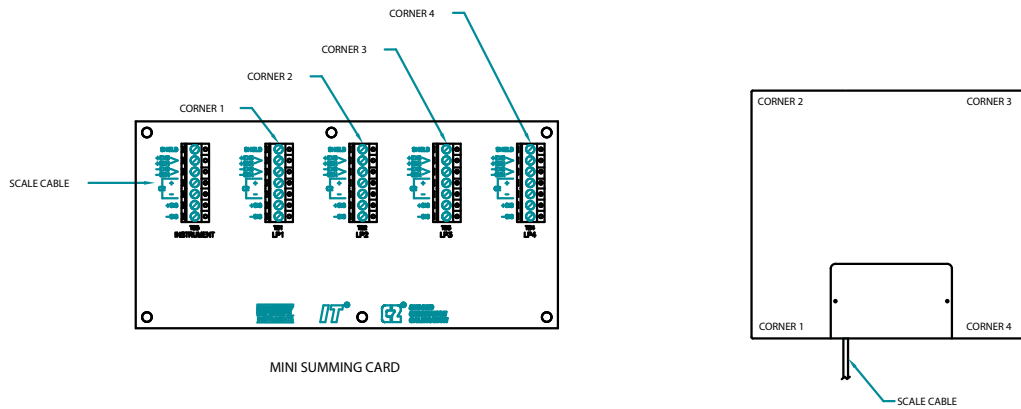
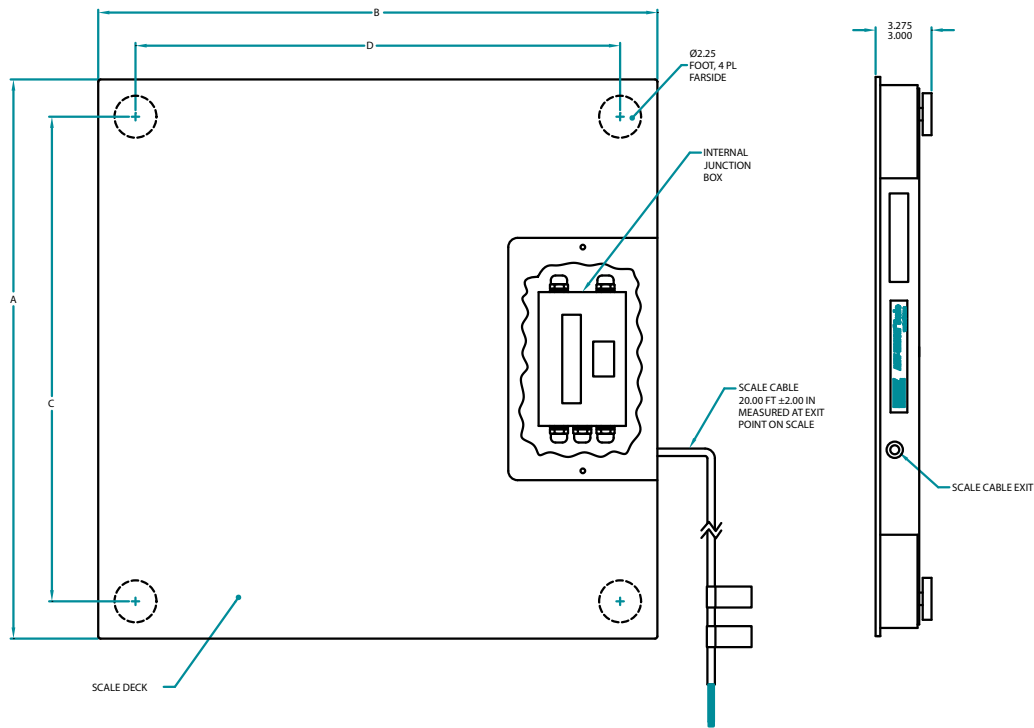

## ANY-WEIGH Accessories

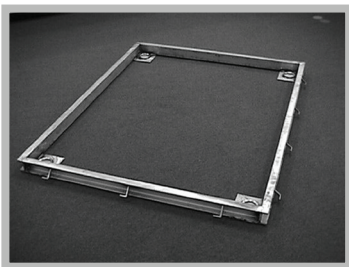

Pit Frames - HI APF Series

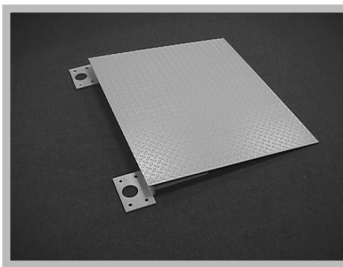

Access Ramps - HI AR Series

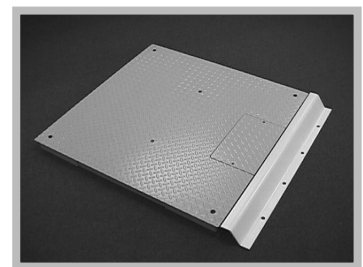

Bumper Guards - HI ABG Series

# WORLDWIDE LOCATIONS



**FREE Online and Phone  
Support Anytime**  
**1-800-821-5831 x 1757**  
**[www.hardysolutions.com](http://www.hardysolutions.com)**

Unrestricted Access to Manuals and Drawings Online  
Free Dial-In Technical Support and Applications Support  
Onsite Certified Technicians for Hire

Follow us on Facebook and LinkedIn



All information within is subject to change without notice. Visit our website for latest specifications. WAVERSAVER, C2, IT, ADVANTAGE and ANY-WEIGH are registered trademarks of Hardy Process Solutions, Inc.. Encompass is a trademark of Rockwell Automation, Inc. All other trademarks or registered trademarks are the property of their respective owners.

**HARDY**  
**PROCESS SOLUTIONS**  
Measurement • Automation • Productivity

Headquarters:  
9440 Carroll Park Drive  
San Diego, CA 92121  
tel. +1-858-278-2900  
tel. 800-821-5831  
fax +1-858-278-6700  
[www.hardysolutions.com](http://www.hardysolutions.com)  
[hardyinfo@hardysolutions.com](mailto:hardyinfo@hardysolutions.com)

**ISO 9001:2008**  
**CERTIFIED**

Since 1993

LPSG-Rev3  
0401-0002-01C