

HI 6100 SERIES FRONT PANEL DISPLAY OPTION

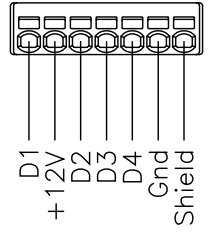

FRONT PANEL DISPLAY TERMINAL BLOCK

- NOTES:
1. INPUT VOLTAGE RANGE:
12 VDC, 0.16 AMP, 1.92 WATT.
 2. SEE USER'S GUIDE FOR ADDITIONAL INFORMATION ON DISPLAY TERMINATIONS.
 3. WIRE SIZE: 20 AWG MAXIMUM / 26 AWG MINIMUM.
WIRE TEMPERATURE RATING TO BE 90° C.
TERMINAL TYPE: SPRING CAGE CONTACT.
INSERTION/RELEASE TOOL: 2.0MM X .4MM WIDE SCREW DRIVER BLADE.
 4. SEE SHEET 5 FOR HI 6510 UNIT WIRE DISPLAY TERMINATIONS.
 4. MAXIMUM CABLE LENGTH: 100 FEET [30.48 METERS]

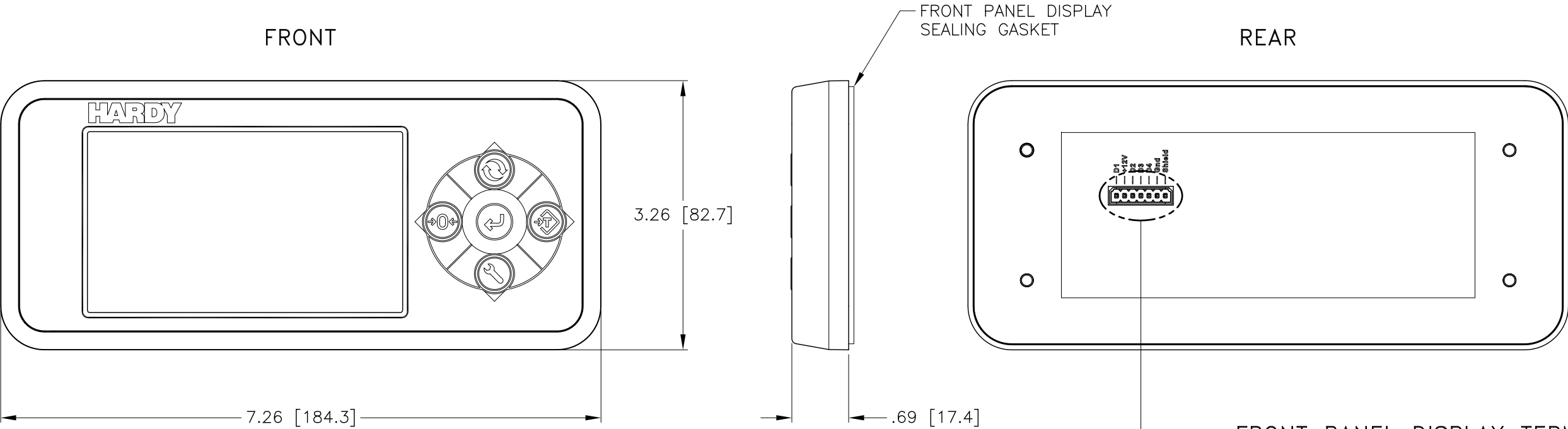
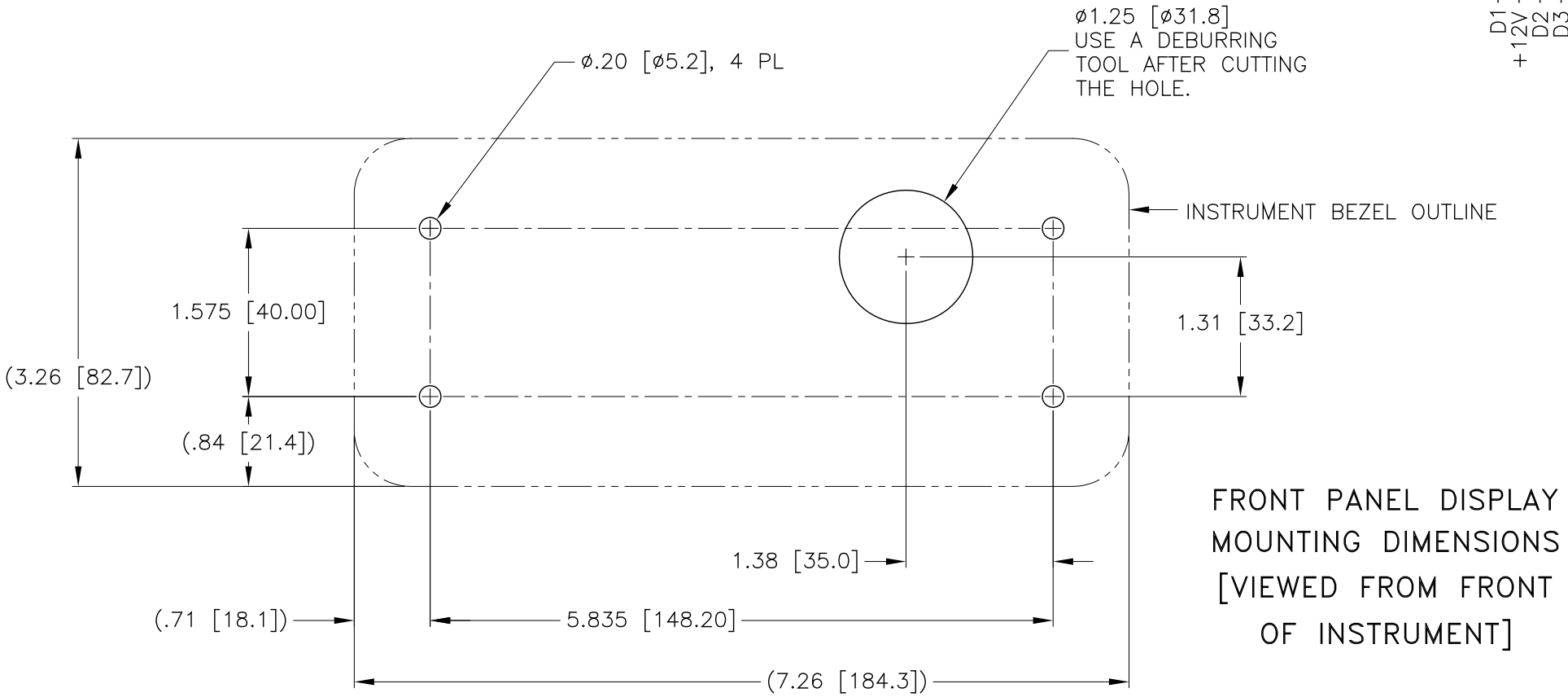

FRONT PANEL DISPLAY MOUNTING DIMENSIONS [VIEWED FROM FRONT OF INSTRUMENT]

DIMENSIONS = IN [MM]

HARDY PROCESS SOLUTIONS			
TITLE I/I DIAGRAM, HI 6300 WEIGHT PROCESSOR			
SIZE	FSCM	DRAWING NO.	REV.
D	21316	0584-0076	E
FILE NAME: 584076E1.DWG		SCALE: NONE	SHEET 2 OF 8

HI 6300 WEIGHT PROCESSOR PANEL MOUNTING ARRANGEMENTS

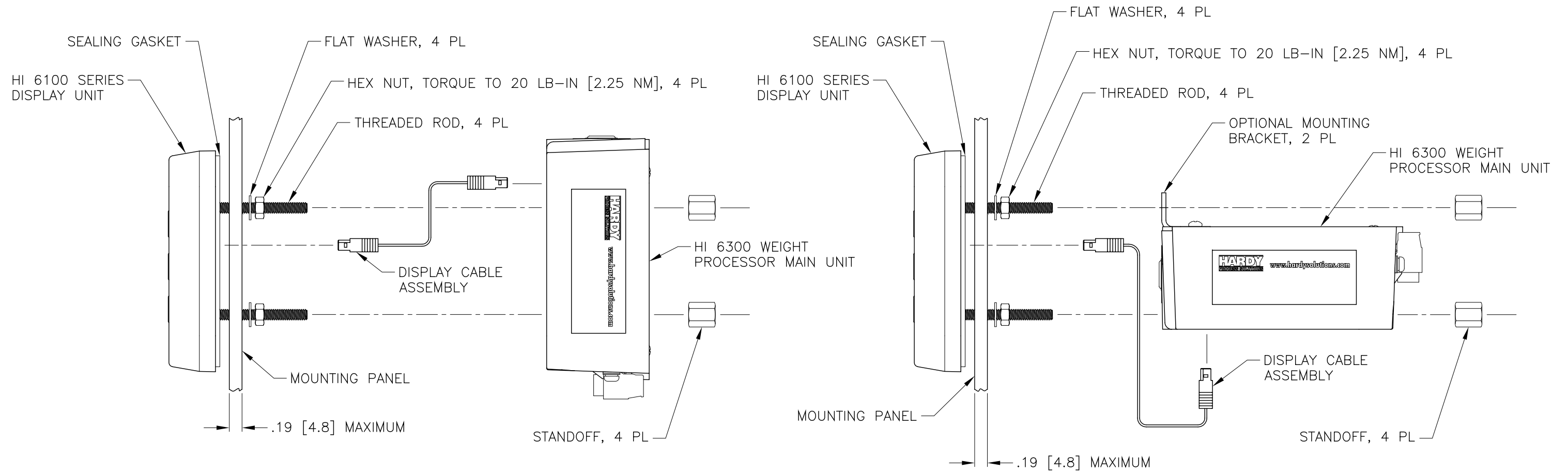

PANEL MOUNT ARRANGEMENT – HI 6300 WEIGHT WITH DISPLAY OPTION

WHEN ORDERED, DISPLAY OPTION IS SUPPLIED WITH THE FOLLOWING PARTS:

- DISPLAY UNIT (1)
- GASKET (1)
- 4.00±.12 [101.6±3.0] LONG DISPLAY CABLE ASSEMBLY (1)
- THREADED ROD (4)
- FLAT WASHER (4)
- HEX NUT (4)
- STANDOFF (4)

ALTERNATIVE PANEL MOUNT ARRANGEMENT

USES SAME PARTS AS SUPPLIED WITH HI 6100 SERIES DISPLAY OPTION.
 OPTIONAL MOUNTING BRACKETS ARE INCLUDED IN HARDWARE KIT PART
 NUMBER 0551-0653-01-0.
 HARDWARE KIT PART NUMBER 0551-0653-01-0 IS TO BE ORDERED SEPARATELY.

DIMENSIONS = IN [MM]

HARDY PROCESS SOLUTIONS			
TITLE I/I DIAGRAM, HI 6300 WEIGHT PROCESSOR			
SIZE	FSCM	DRAWING NO.	REV.
D	21316	0584-0076	E
FILE NAME: 584076E1.DWG		SCALE: NONE	SHEET 3 OF 8

WEIGH SCALE INPUT TERMINATIONS

NOTES:

1. IF CONDUIT IS USED, DO NOT RUN LOAD CELL CABLE PARALLEL TO, OR IN SAME CONDUIT WITH, POWER WIRING, RELAY CABLE OR OTHER HIGH ENERGY CABLES.
2. 2 FACTORY INSTALLED JUMPERS TO REMAIN IN PLACE ONLY FOR FOUR WIRE NON C2 LOAD CELL CONNECTION. JUMPERS TO BE REMOVED FOR SIX WIRE NON C2 OR EIGHT WIRE C2 LOAD CELL CONNECTIONS. EXCITATION AND SENSE WIRES TO BE CONNECTED TOGETHER IN JUNCTION BOX.
3. REQUIRED LOAD CELL CABLE FOR C2 SECOND GENERATION CALIBRATION SYSTEM AND INTEGRATED TECHNICIAN: HARDY PROCESS SOLUTIONS P/N 6020-0001.
4. SEE USER'S GUIDE FOR ADDITIONAL INFORMATION ON LOAD CELL CONNECTIONS. USER'S GUIDE IS LOCATED ON HARDY PROCESS SOLUTIONS WEB SITE.
5. TERMINAL BLOCK WIRE SIZE RANGE: 22 AWG MIN / 16 AWG MAX. WIRE TEMPERATURE RATING TO BE 90° C. WIRE TIGHTENING TORQUE: 2 LB-IN MINIMUM / 4 LB-IN MAXIMUM.
6. FOR CLARITY, ONLY ONE LOAD SENSOR CONNECTION IS SHOWN.

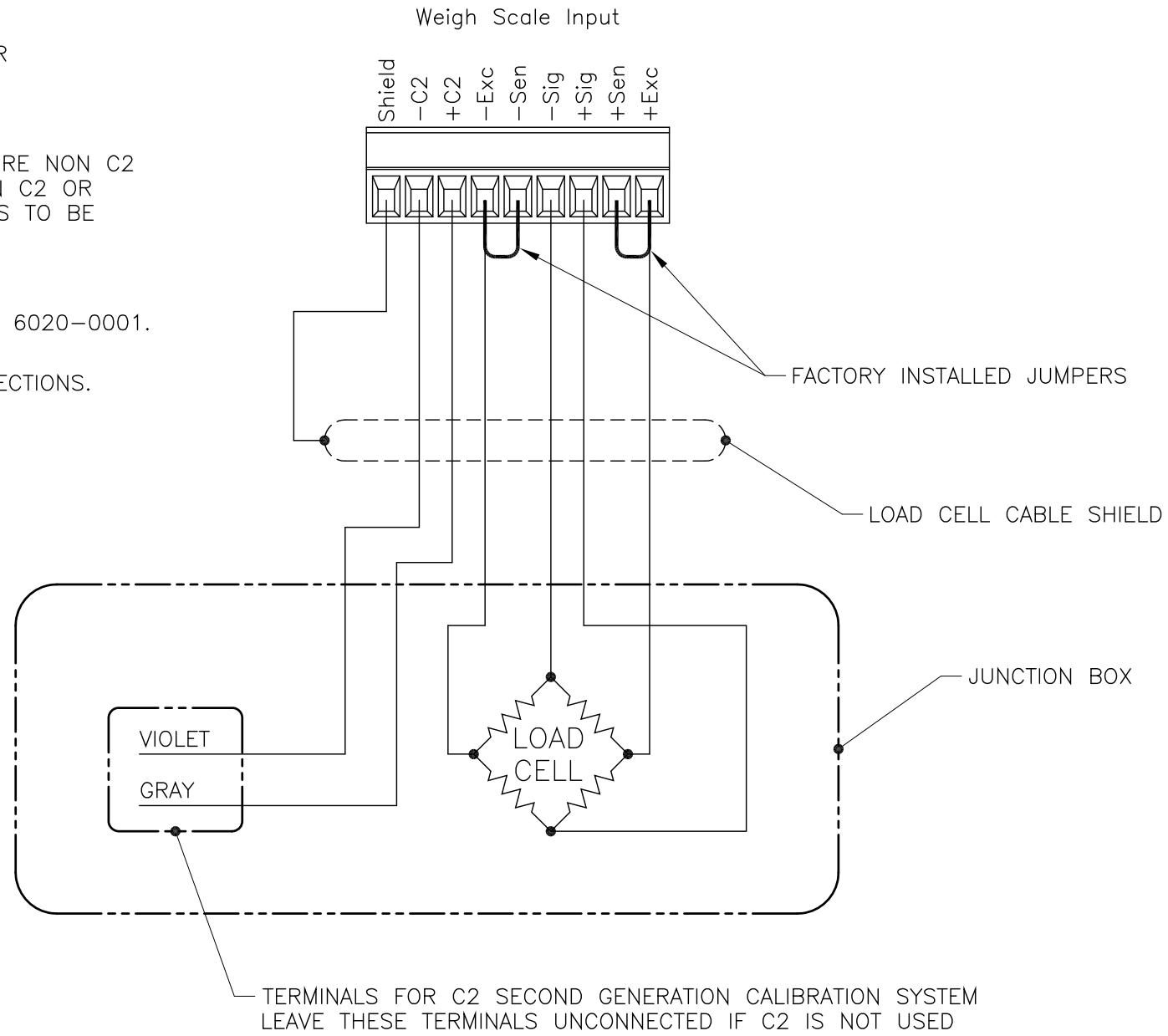

DIMENSIONS = IN [MM]

HARDY PROCESS SOLUTIONS			
TITLE I/I DIAGRAM, HI 6300 WEIGHT PROCESSOR			
SIZE	FSCM	DRAWING NO.	REV.
D	21316	0584-0076	E
FILE NAME: 584076E1.DWG		SCALE: NONE	SHEET 4 OF 8

POWER INPUT TERMINATIONS

NOTES:

1. INPUT VOLTAGE RANGE [24VDC NOMINAL]:
12–24 VDC, 0.15–0.33 AMP, 4 WATTS MAXIMUM
2. TERMINAL BLOCK WIRE SIZE RANGE:
WIRE TEMPERATURE RATING TO BE 90° C.
12 AWG MAXIMUM / 22 AWG MINIMUM.
WIRE TIGHTENING TORQUE:
4.4 LB-IN MINIMUM / 5.3 LB-IN MAXIMUM.

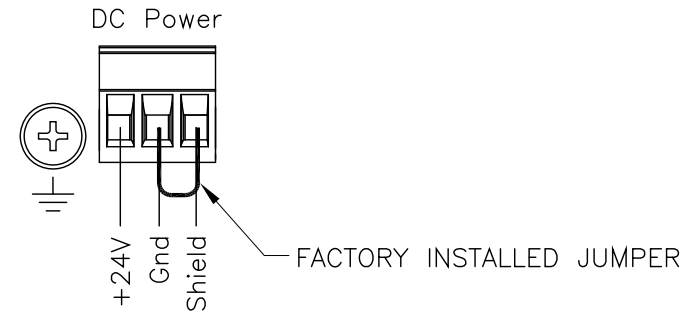

SERIAL PORT TERMINATIONS

NOTES:

1. SEE USER'S GUIDE FOR ADDITIONAL INFORMATION ON SERIAL TERMINATIONS.
2. DO NOT BUNDLE SERIAL WIRING WITH POWER WIRING, RELAY CABLE OR ANY OTHER HIGH ENERGY CABLES.
3. TERMINAL BLOCK WIRE SIZE RANGE: 22 AWG MIN / 16 AWG MAX.
WIRE TEMPERATURE RATING TO BE 90° C.
WIRE TIGHTENING TORQUE: 2 LB-IN MINIMUM / 4 LB-IN MAXIMUM.
4. "DNC" = DO NOT CONNECT.

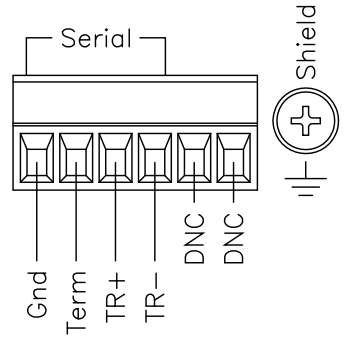

ETHERNET TERMINATION

NOTES:

1. SEE USER'S GUIDE FOR ADDITIONAL INFORMATION ON ETHERNET TERMINATIONS.
2. CONNECTOR TYPE: RJ-45, 8 PIN
3. N.C. = NOT CONNECTED.

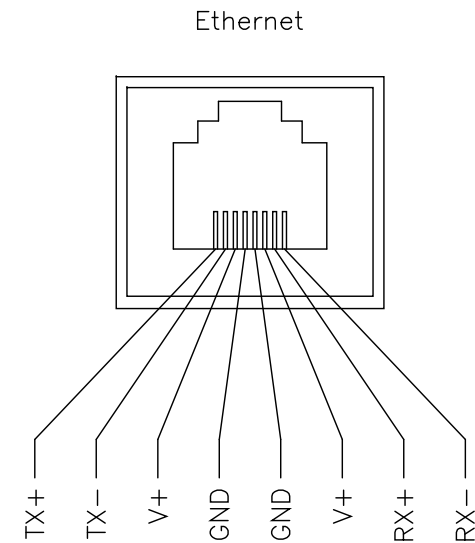

DISPLAY TERMINATIONS

NOTES:

1. SEE USER'S GUIDE FOR ADDITIONAL INFORMATION ON DISPLAY TERMINATIONS.
2. WIRE SIZE: 20 AWG MAXIMUM / 26 AWG MINIMUM.
WIRE TEMPERATURE RATING TO BE 90° C.
TERMINAL TYPE: SPRING CAGE CONTACT.
INSERTION/RELEASE TOOL: 2.0MM X .4MM WIDE SCREW DRIVER BLADE.
3. SEE SHEET 2 FOR FRONT PANEL DISPLAY WIRE TERMINATIONS.
4. MAXIMUM CABLE LENGTH: 100 FEET [30.48 METERS]

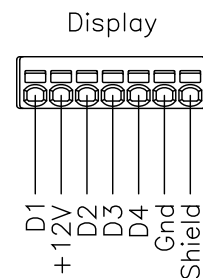

DIMENSIONS = IN [MM]

HARDY
PROCESS SOLUTIONS

TITLE
I/I DIAGRAM,
HI 6300 WEIGHT PROCESSOR

SIZE	FSCM	DRAWING NO.	REV.
D	21316	0584-0076	E

FILE NAME: 584076E1.DWG	SCALE: NONE	SHEET 5 OF 8
-------------------------	-------------	--------------

HI 6300 WEIGHT PROCESSOR PANEL MOUNT WALL SYSTEM [OPTION PMWS]

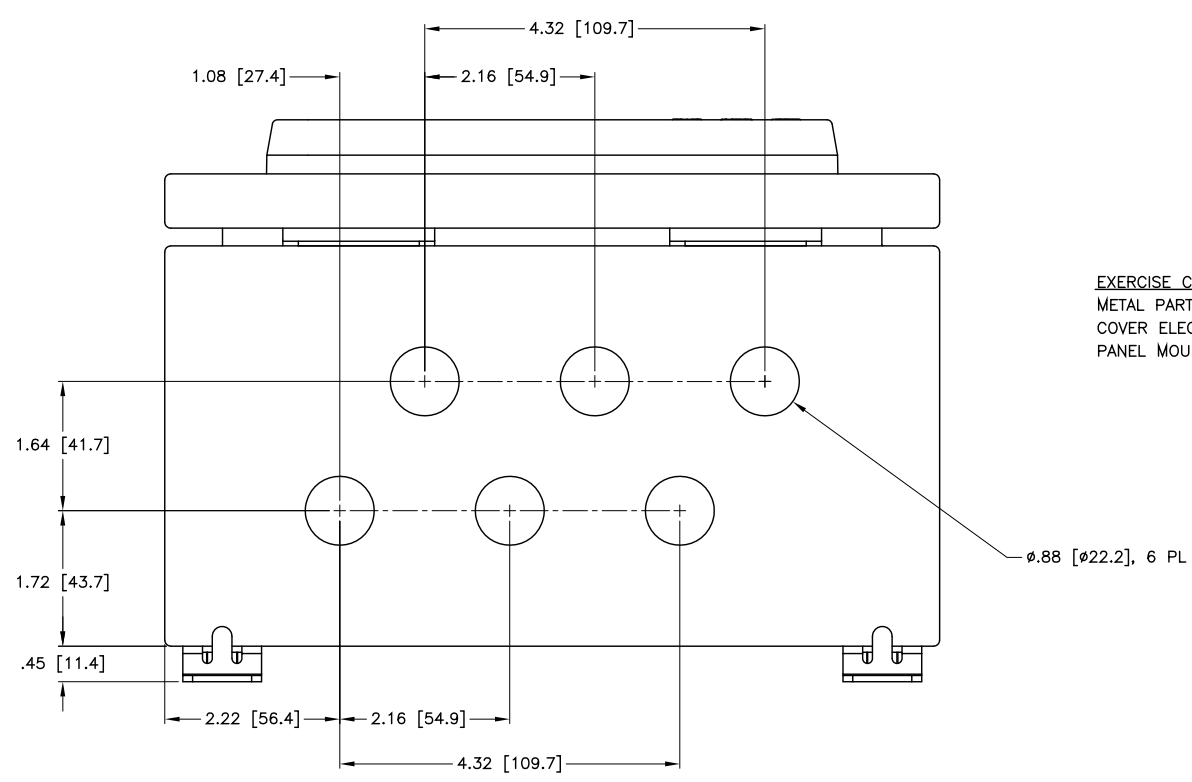
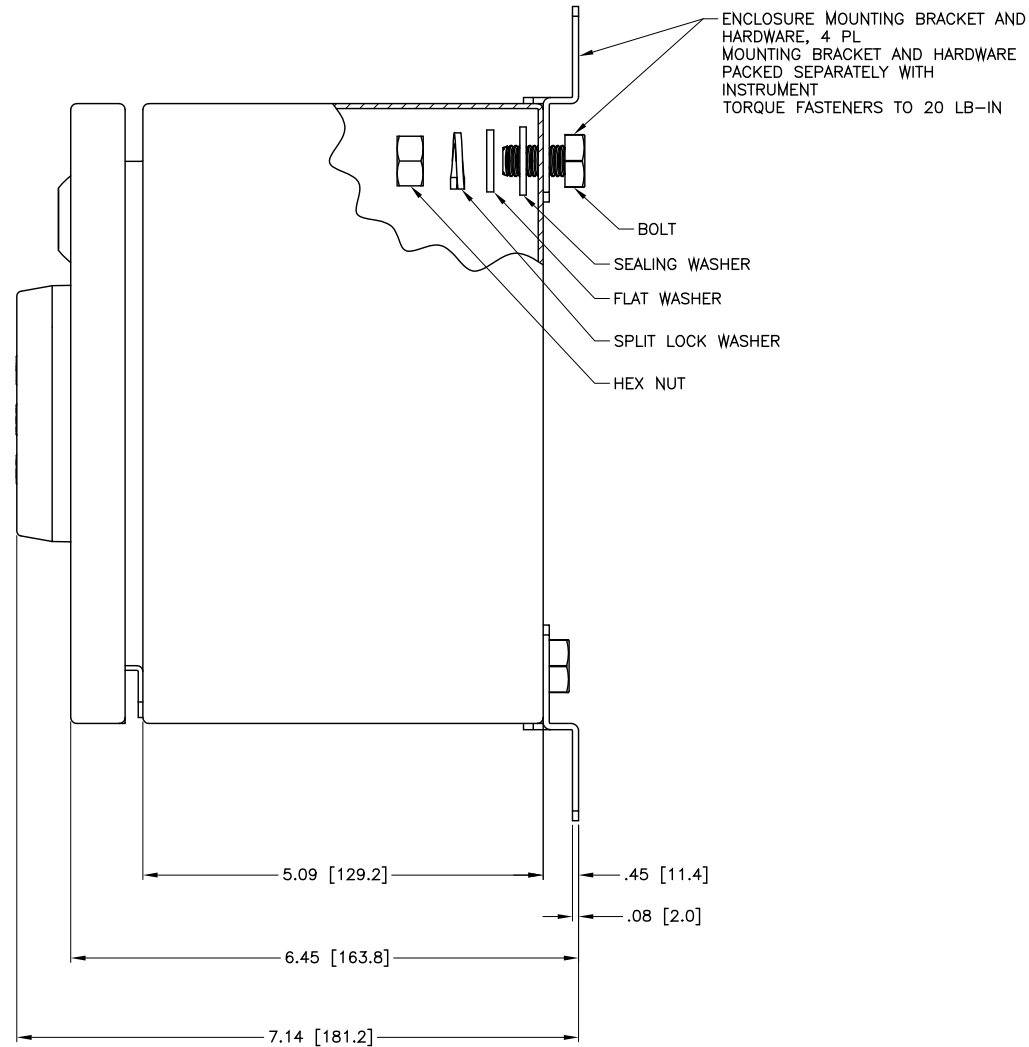
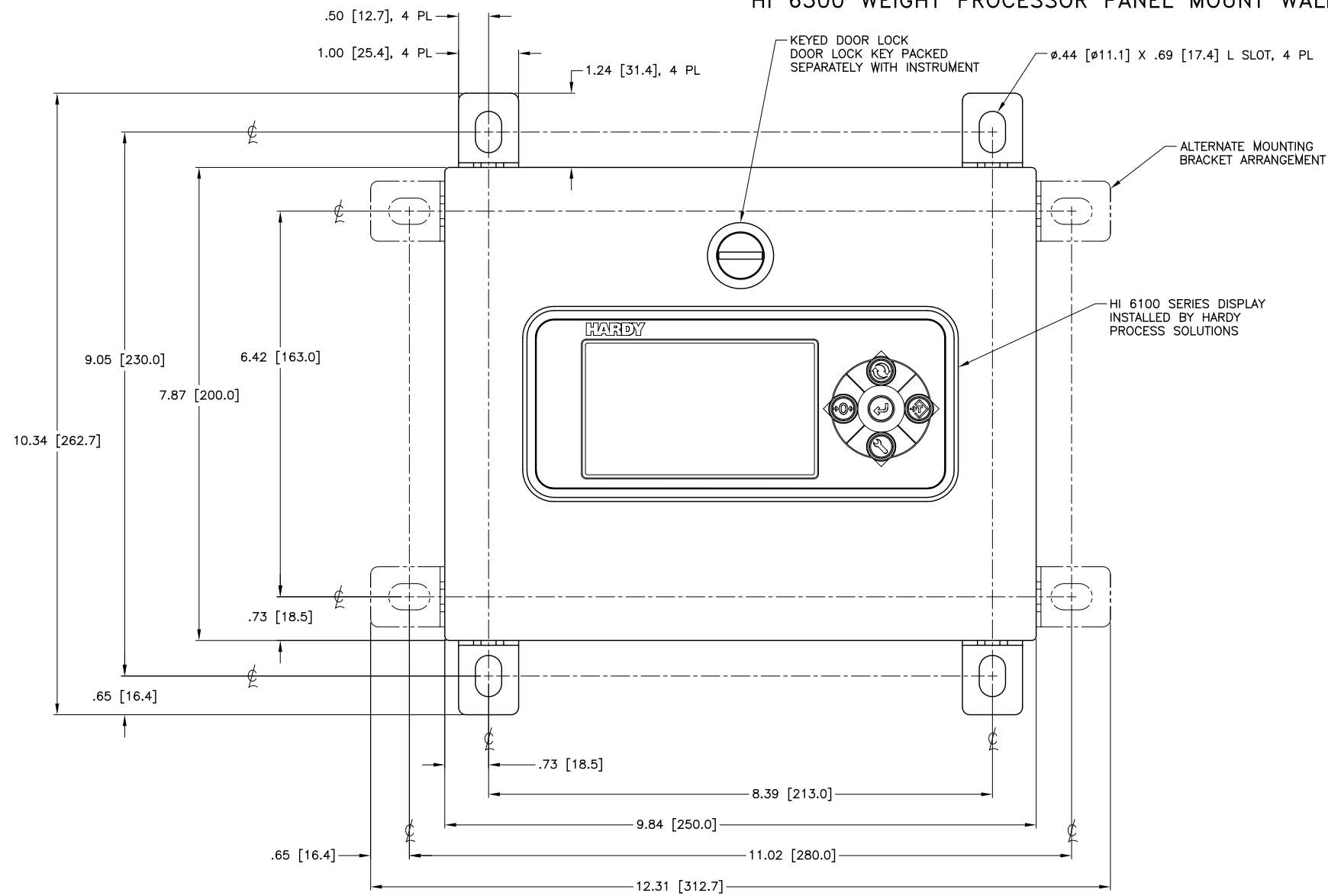

EXERCISE CAUTION WHEN ADDING OR ENLARGING HOLES IN PANEL MOUNT WALL SYSTEM ENCLOSURE!
 METAL PARTICLES COULD SERIOUSLY DAMAGE ELECTRONICS.
 COVER ELECTRONICS BEFORE DRILLING OR PUNCHING.
 PANEL MOUNT WALL SYSTEM ENCLOSURE DOOR TO REMAIN FREE OF ADDITIONAL HOLES.

DIMENSIONS = IN [MM]

HARDY PROCESS SOLUTIONS			
TITLE I/I DIAGRAM, HI 6300 WEIGHT PROCESSOR			
SIZE	FSCM	DRAWING NO.	REV.
D	21316	0584-0076	E
FILE NAME: 584076E1.DWG		SCALE: NONE	SHEET 6 OF 8

HI 6300 WEIGHT PROCESSOR PANEL MOUNT WALL SYSTEM [OPTION PMWS] – INTERNAL COMPONENTS

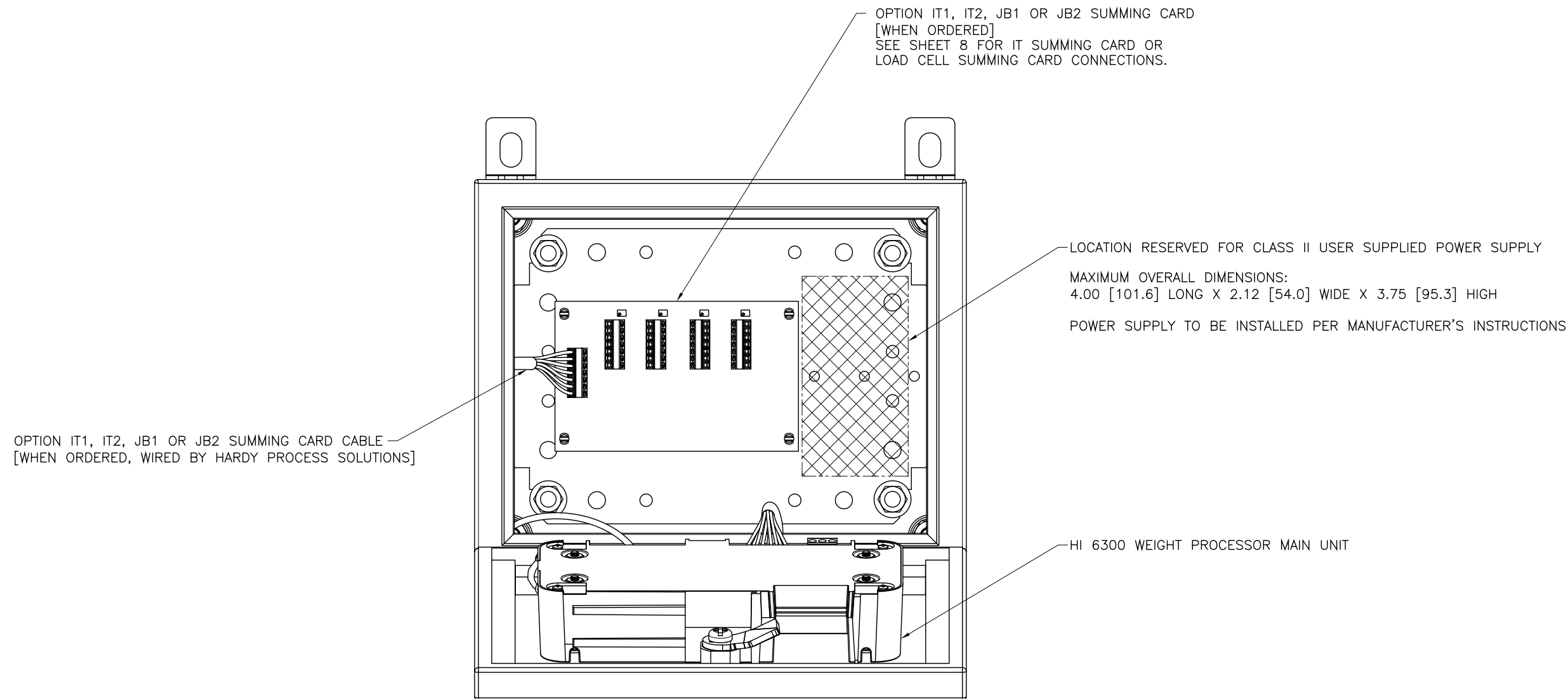

CABLE GLAND FITTINGS, NUTS AND SEALING PLUGS, QTY 6 EACH, ARE PACKED SEPARATELY INSIDE ENCLOSURE [SEALING PLUG TO BE INSTALLED INTO CABLE GLAND FITTING WHEN SIGNAL CABLE IS NOT USED]

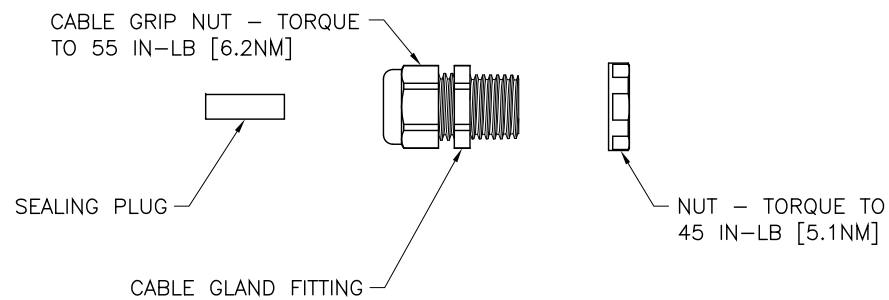

NOTE:
 FOR CLASS I, II, III DIV. 2 APPLICATIONS, THE CABLE GLAND SET PROVIDED WITH THE UNIT ARE NOT ACCEPTABLE. THE CUSTOMER IS RESPONSIBLE FOR REPLACING THE CABLE GLAND SET WITH THE APPROPRIATE CONDUIT FITTINGS TO MEET THE HAZARDOUS AREA REQUIREMENTS. WIRE PER LOCAL ELECTRICAL CODE.

HARDY PROCESS SOLUTIONS			
TITLE I/I DIAGRAM, HI 6300 WEIGHT PROCESSOR			
SIZE	FSCM	DRAWING NO.	REV.
D	21316	0584-0076	E
FILE NAME: 584076E1.DWG		SCALE: NONE	SHEET 7 OF 8

OPTION CODES IT1 & IT2 – IT SUMMING CARD
 OPTION CODES JB1 & JB2 – LOAD CELL SUMMING CARD

IT SUMMING/LOAD CELL SUMMING CARD

NOTES:

- DO NOT RUN LOAD CELL CABLES PARALLEL TO, OR IN THE SAME CONDUIT WITH POWER WIRING, RELAY CABLE OR OTHER HIGH ENERGY CABLES.
- REQUIRED LOAD CELL CABLE FOR C2 SECOND GENERATION CALIBRATION SYSTEM: HARDY PROCESS SOLUTIONS PART NUMBER 6020-0001-0.
- SEE USER'S GUIDE FOR ADDITIONAL INFORMATION ON IT SUMMING/LOAD CELL SUMMING CARD CONNECTIONS.
- WIRE SIZE: 12 AWG MAXIMUM / 22 AWG MINIMUM.
 WIRE TIGHTENING TORQUE: 2 LB-IN MINIMUM / 4 LB-IN MAXIMUM.

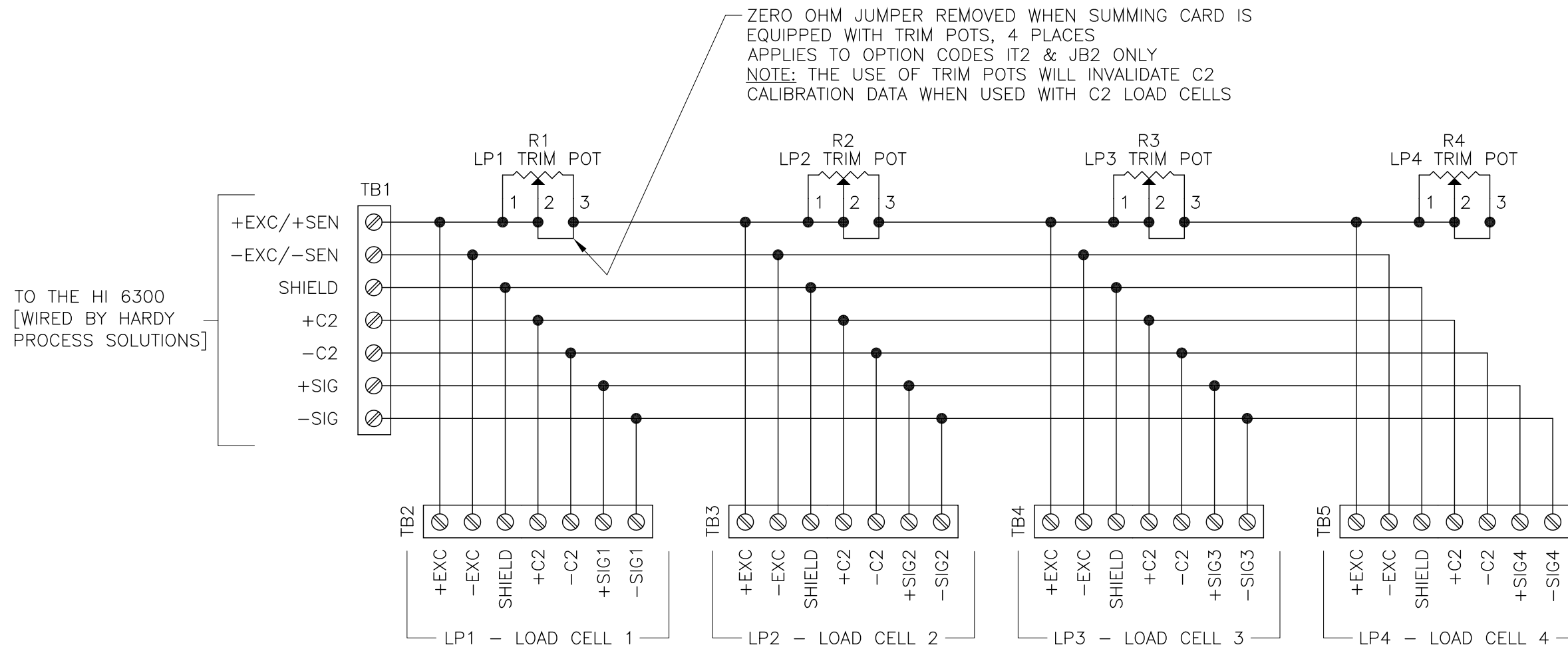
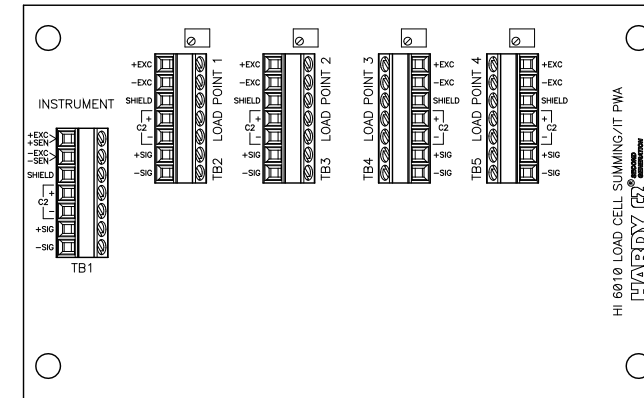

IT SUMMING/LOAD CELL SUMMING CARD WIRING DIAGRAM

HARDY PROCESS SOLUTIONS			
TITLE I/I DIAGRAM, HI 6300 WEIGHT PROCESSOR			
SIZE D	FSCM 21316	DRAWING NO. 0584-0076	REV. E
FILE NAME: 584076E1.DWG		SCALE: NONE	SHEET 8 OF 8