

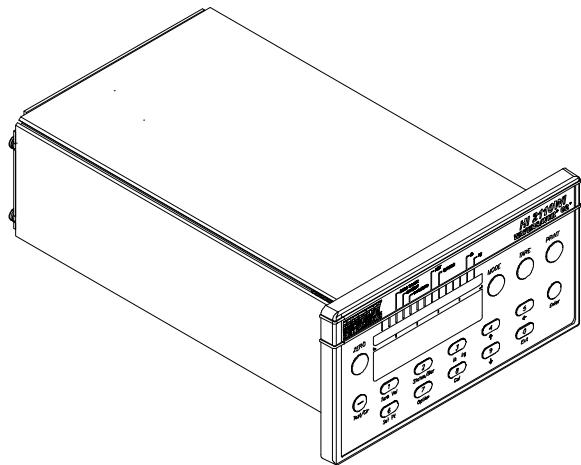

HI 2110WI
Weight Controller
Operation and Installation Manual



Corporate Headquarters
3860 Calle Fortunada
Phone: (858) 278-2900
FAX: (858) 278-6700
Web-Site: <http://www.hardyinstruments.com>

Table of Contents

Table of Contents - - - - - **i**

Table of Illustrations - - - - - **1**

Chapter 1

Overview - - - - - **1-1**

Scope - - - - - 1-1

About This Manual - - - - - 1-1

Description- - - - - 1-1

WAVERSAVER® - - - - - 1-2

C2® Calibration - - - - - 1-2

 Secure Memory Module (SMM)- - - - - 1-3

 Remote Functions - - - - - 1-3

 Auto Zero Tracking- - - - - 1-3

 Output Device Options - - - - - 1-3

 Analog Output (-B1) - - - - - 1-3

 Binary Coded Decimal (BCD) Output (-B2) - - - - - 1-3

 Binary Coded Decimal (BCD) Output (-B5) - - - - - 1-4

 BCD Single Termination Card (-B6)- - - - - 1-4

 BCD Quad Termination Card (-B7) - - - - - 1-4

 Remote I/O (RIO) Interface to the Allen-Bradley Network (-B8) - - - - 1-4

 Binary Coded Decimal (BCD) Output (-B9) - - - - - 1-4

 PROFIBUS Interface Option (-B12)- - - - - 1-4

 Miscellaneous Options - - - - - 1-4

 1240 VAC 50/60 Hz Input Voltage (-E2) - - - - - 1-4

Chapter 2

Specifications- - - - - - **2-1**

SCOPE - - - - - 2-1

HI 2110WI Specifications for a Standard Instrument- - - - - 2-1

 Conversion Rate - - - - - 2-1

 Resolution - - - - - 2-1

 Excitation Voltage - - - - - 2-1

 Averages - - - - - 2-1

 Input- - - - - 2-1

 Display- - - - - 2-1

 Display Increments (Graduations) - - - - - 2-1

 Key Pad - - - - - 2-1

 Non-Linearity- - - - - 2-1

 Maximum Zero Tolerance - - - - - 2-1

 WAVERSAVER® - - - - - 2-1

Power and Utility Requirements - - - - - 2-2

 Voltage - - - - - 2-2

 Frequency - - - - - 2-2

 Power - - - - - 2-2

 Common Mode Voltage Range - - - - - 2-2

 Common Mode Rejection- - - - - 2-2

 Approvals - - - - - 2-2

Environmental Requirements - - - - - 2-2

 Operating Temperature Range - - - - - 2-2

 Storage Temperature Range - - - - - 2-2

 Temperature Coefficient - - - - - 2-2

 Humidity Range - - - - - 2-2

Physical Characteristics - - - - - 2-2

 Panel Mount (Model # HI 2110WI) - - - - - 2-2

 Remote Mount Model HI 2110WI-RM- - - - - 2-3

Optional Equipment - - - - - 2-3

 Analog Output (-B1) - - - - - 2-3

Binary Coded Decimal (BCD) (-B2) - - - - -	2-4
Binary Coded Decimal (BCD) (-B5) - - - - -	2-5
BCD Single Termination Board (-B6) - - - - -	2-5
BCD Quad Termination Board (-B7) - - - - -	2-5
Allen-Bradley Remote I/O Interface (-B8) - - - - -	2-5
Binary Coded Decimal (BCD) (-B9) - - - - -	2-6
Profibus I/O Interface (-B12) - - - - -	2-6

Chapter 3

Installation - - - - -	3-1
SCOPE - - - - -	3-1
Unpacking - - - - -	3-1
Mechanical Installation - - - - -	3-1
Installing the HI 2110WI in a Panel - - - - -	3-1
Installing the HI 2110WI Panel Mount - - - - -	3-2
Installing the HI 2110WI Remote Mount Model - - - - -	3-4
Installation of the Front Panel - - - - -	3-4
Installation of the Instrument Enclosure - - - - -	3-5
Electrical Installation - - - - -	3-6
Cabling and Interconnecting - - - - -	3-6
Recommended Installation Procedures - - - - -	3-6
Input Power Wiring - - - - -	3-7
Remote Functions Wiring - - - - -	3-8
Load Cell/Point Connections (J1) - - - - -	3-8
C2 Load Cell Connections (J1) (See Fig. 3-7) - - - - -	3-9
Non C2 Load Cell Connections (J1) (See Fig. 3-8) - - - - -	3-9
Non C2 Load Sensor Connections (J1) - - - - -	3-10
OUTPUT OPTION BOARD INSTALLATION PROCEDURES - - - - -	3-10
Options Cabling and Interconnect - - - - -	3-12
Analog Output Option -B1 (See Fig. 3-10)- - - - -	3-12
BCD Option Board Installation Procedures -B2, -B5, -B9 - - - - -	3-12
Profibus Interface Card Option Wiring Diagram - - - - -	3-18
Installation of the Secure Memory Module - - - - -	3-19

Chapter 4

Configuration - - - - -	4-1
SCOPE - - - - -	4-1
Analog Output Option Card Configuration Procedures -B1- - - - -	4-1
About the Analog Output Card Option - - - - -	4-1
Setting the Jumpers - - - - -	4-1
Disassembling the Rear Panel and Setting Jumpers - - - - -	4-1
Analog Card Adjustment4-2	
Parallel BCD Board Print Configuration Procedures -B2, -B5, -B9 - - - - -	4-3
About the BCD Board Print Output Signal - - - - -	4-3
Auto Zero Tolerancing Configuration Procedures - - - - -	4-4
About Auto Zero Tolerancing - - - - -	4-4
Dip Switch Location (See Fig. 4-4) - - - - -	4-4
Dip Switch Setting - - - - -	4-4
Configuring Lock S3-7 - - - - -	4-5
Configuring the Power Board Dip Switches S2 (See Fig. 4-5) - - - - -	4-5

Chapter 5

Setup - - - - -	5-1
SCOPE - - - - -	5-1
Keypad Functions (See Fig. 5-1) - - - - -	5-1
Zero - - - - -	5-1
Mode - - - - -	5-1
Tare - - - - -	5-1
—/Test/Clr - - - - -	5-2
1/Tare Val - - - - -	5-2

3/Lb Kg - - - - - 5-2
 4/↑? - - - - - 5-2
 5/← - - - - - 5-2
 8/Cal- - - - - 5-2
 9/↓ - - - - - 5-2
 Exit - - - - - 5-2
 Enter- - - - - 5-3
 BCD Menu Setup Procedures - - - - - 5-3
 About BCD Communication (See Chapter 4 for Configuration
 Procedures) - - - - - 5-3
 Setup Procedures - - - - - 5-3
 Output Mode Options - - - - - 5-4
 Tare Mode - - - - - 5-4
 Net Mode - - - - - 5-4
 Gross Mode - - - - - 5-4
 Analog Output Setup Procedures (Option) - - - - - 5-5
 About Analog Output (See Chapter 4 for Configuration Procedures) - - - - - 5-5
 Analog Output Menu Setup Procedures- - - - - 5-5
 Set Up for Profibus Interface Card Option -B12 - - - - - 5-5
 Allen-Bradley Remote I/O Option -B8 - - - - - 5-5

Chapter 6

Calibration - - - - - 6-1
 SCOPE - - - - - 6-1
 Pre-Calibration Procedures- - - - - 6-1
 Mechanical Check Procedures - - - - - 6-1
 Electrical Check Procedures - - - - - 6-2
 Fourteen Segment Display - - - - - 6-3
 Status Indicator - - - - - 6-4
 Load Check - - - - - 6-5
 Calibration Setup Procedures- - - - - 6-5
 The Calibration Menu - - - - - 6-5
 Setting the Unit of Measure (UNIT) - - - - - 6-6
 Setting the Standard Decimal Point (DECPNT) - - - - - 6-6
 Setting the Motion Tolerance Value (MOTION) - - - - - 6-6
 Setting the Graduation Size (GRAD) - - - - - 6-6
 Setting the Zero Tolerance (0 TOL)- - - - - 6-7
 Setting The Auto Zero Tolerance (A0 TOT) - - - - - 6-7
 Setting the Number of Readings Averaged (AVRAGE) - - - - - 6-7
 Setting the Scale Capacity (SC CAP) - - - - - 6-8
 WAVERSAVER® (WVRSVR)- - - - - 6-8
 Calibration Procedures - - - - - 6-8
 C2™ Second Generation Calibration Procedures - - - - - 6-8
 Setting the Reference Point (REF PT) - - - - - 6-9
 Using the Return Button (RETURN) - - - - - 6-9
 C2 Calibration Self Test Procedures - - - - - 6-10
 Hard Calibration Procedures (HDCAL) - - - - - 6-10
 Selecting the Hard Calibration Sub-Menu - - - - - 6-10
 Setting the Zero Calibration Value - - - - - 6-11
 Setting the Span Calibration Value - - - - - 6-11
 Setting the Linear Correction Value- - - - - 6-11
 The Return (RETURN) Display - - - - - 6-12
 Checking for Mechanical Problems - - - - - 6-12
 Hard Calibration Self Test Procedures (Traditional Method
 Using Test Weights) - - - - - 6-12
 Quick C2™ Calibration Procedures- - - - - 6-13
 About Quick C2 Calibration- - - - - 6-13
 Quick Hard Calibration Procedures (Traditional Calibration using
 Test Weights) - - - - - 6-13

Procedures to Restore Calibration Parameters (Not Used for
Systems that are Calibrated Using C2) - - - - - 6-14
 Before Clearing Memory - - - - - 6-14
 Clear Controller Memory - - - - - 6-14
 Restoring Calibration When Changing Decimal Points- - - - - 6-15
 Restoring Decimal Points- - - - - 6-15

Chapter 7

Operation - - - - - 7-1
SCOPE - - - - - 7-1
Description of Front Panel - - - - - 7-1
Process Weighing Function Buttons - - - - - 7-1
Operator Displays - - - - - 7-2
Instrument Operation Overview - - - - - 7-2
Option Menus and Option Parameters - - - - - 7-2
Option Boards - - - - - 7-3
 General Information - - - - - 7-3
Parallel BCD Communication - - - - - 7-3
 Operating Procedures - - - - - 7-3
 BCD Print - - - - - 7-4
 Output Disable - - - - - 7-4
 Allen-Bradley Remote I/O Option -B8 - - - - - 7-4
 Profibus Interface Option -B12 - - - - - 7-4

Chapter 8

Troubleshooting Procedures - - - - - 8-1
SCOPE - - - - - 8-1
Disassembly and Reassembly Notes and Cautions - - - - - 8-1
General Troubleshooting Flow Chart Index - - - - - 8-2
A- Guidelines for Instabilities on Formerly Operating Systems - - - - - 8-3
A1- Guidelines for Instabilities on Formerly Operating Systems (Cont'd) - - - - - 8-4
B- Guidelines for Instabilities on Formerly Operating Systems (Cont'd)- - - - - 8-5
B1 - Guidelines for Instabilities on Former Operating Systems (Cont'd) - - - - - 8-6
B2- Guidelines for Instabilities on Formerly Operating
 Systems: Mechanical Stability and Configuration Settings - - - - - 8-7
C - Guidelines for Instabilities on Formerly Operating Systems - - - - - 8-8
E - Non-Return to ZERO - - - - - 8-9
F - Verify Individual Load Cell Milli-Volt Readings - - - - - 8-10
G - Error 18 During Hard Calibration - - - - - 8-11
H - Mechanical Inspection - - - - - 8-12
J - Electrical Inspection - - - - - 8-13
K - Load Sharing and Load Sensor Checkout - - - - - 8-14
M - HI Error - - - - - 8-15
N - Blank Screen - - - - - 8-16
System Integrity Check and Fault Determination - - - - - 8-17
 Self-Test - - - - - 8-17
Interpreting Diagnostic/error Messages - - - - - 8-21
 Overview of Typical Load Cell System - - - - - 8-21
 No Keypad Operation - - - - - 8-23
 Remote Functions Non-Operational- - - - - 8-23
Error Messages and Definitions- - - - - 8-23

**System data survey
sheet**

self test display

Options

Glossary of Terms

Table of Illustrations

CHAPTER 1	OVERVIEW - - - - -	1-1
	FIG. 1-1 WEIGHT CONTROLLER - - - - -	1-2
CHAPTER 3	INSTALLATION - - - - -	3-1
	FIG. 3-1 2" REAR PANEL CLEARANCE REQUIREMENT - - - - -	3-2
	FIG. 3-2 PANEL CUTOUT DIMENSIONS - - - - -	3-3
	FIG. 3-3 NEMA 4 GASKET FLUSH AGAINST THE FRONT PANEL - - - - -	3-4
	FIG. 3-4 MOUNTING REMOTE DISPLAY TO CUSTOMER'S ENCLOSURE - - - - -	3-5
	FIG. 3-5 INSTALLING ELECTRONICS ENCLOSURE TO A PLATE- - - - -	3-6
	FIG. 3-6 POWER WIRING DIAGRAM - - - - -	3-7
	FIG. 3-7 C2 LOAD CELL CONNECTION- - - - -	3-9
	FIG. 3-8 LOAD CELL CONNECTION (NON C2 LOAD CELLS) J1 - - - - -	3-10
	FIG. 3-9 OPTION LABEL COVER - - - - -	3-11
	FIG. 3-10 ANALOG OUTPUT BOARD- - - - -	3-12
	FIG. 3-11 PARALLEL BCD BOARD - - - - -	3-13
	FIG. 3-12 BCD QUAD TERMINATION BOARD OPTION- - - - -	3-15
	FIG. 3-13 BCD TERMINATION BOARD INSTALLATION DRILL TEMPLATE - - - - -	3-16
	FIG. 3-14 BCD TERMINATION INSTALLATION BLOCK DIAGRAM - - - - -	3-17
	FIG. 3-15 STANDOFF ASSEMBLY - - - - -	3-18
	FIG. 3-16 SECURE MEMORY MODULE - - - - -	3-19
	FIG. 3-17 INSTALLING AND REMOVING THE SECURE MEMORY MODULE - - - - -	3-19
CHAPTER 4	CONFIGURATION - - - - -	4-1
	FIG. 4-1 ANALOG OUTPUT BOARD- - - - -	4-3
	FIG. 4-2 BCD CARD JUMPER LOCATION PRINT/NO PRINT - - - - -	4-3
	FIG. 4-3 BCD JUMPER SETTINGS/PRINT/NO PRINT - - - - -	4-4
	FIG. 4-4 AUTO ZERO DIP SWITCH SETTINGS - - - - -	4-4
	FIG. 4-5 POWER BOARD DIP SWITCH LOCATION - - - - -	4-5
CHAPTER 5	SETUP - - - - -	5-1
	FIG. 5-1 FRONT PANEL- - - - -	5-1
CHAPTER 6	CALIBRATION - - - - -	6-1
	FIG. 6-1 PROPERLY INSTALLED LOAD CELL W/NO BINDING - - - - -	6-2
	FIG. 6-2 MILLIVOLTS/WEIGHT SCALE - - - - -	6-3
	FIG. 6-3 FRONT PANEL DISPLAY WITH NUMBERS - - - - -	6-4
	FIG. 6-4 FRONT PANEL STATUS LEDS DISPLAYED - - - - -	6-4
CHAPTER 7	OPERATION- - - - - -	7-1
	FIG. 7-1 FRONT PANEL, PROCESS WEIGHING FUNCTION BUTTONS- - - - -	7-1
	FIG. 7-2 OPTION MENU TREE - - - - -	7-3

CHAPTER 1 - OVERVIEW

Scope

This manual provides the user and service personnel with a description of the specifications, installation, setup, configuration, operation, communication, maintenance, and troubleshooting procedures for the HI 2110WI Weight Controller. The HI 2110WI is fitted with WAVERSAVER[®] and C2[®] Electronic Calibration. To get the maximum service life from this product, operators should use this instrument in accordance with recommended practices either implied or expressed in this manual. Before using the weight controller, all users and maintenance personnel should read and understand all cautions, warnings, and safety procedures, referenced or explicitly stated in this manual, to ensure the safe operation of this product.

NOTE:

WAVERSAVER[®] and C2[®] are registered Trademarks of Hardy Instruments, Inc.

About This Manual

Every Installation and Operation manual is organized into easily referenced chapters:

- **Chapter One** - Provides an introduction to the instrument and an Overview of the equipment and its capabilities.
- **Chapter Two** - Provides a complete list of Specifications.
- **Chapter Three** - Contains information needed to Install the HI 2110WI (both standard equipment and optional equipment) and the HI 215IT series Junction Box.
- **Chapter Four** - Provides complete hardware Configuration instructions for setting dip switches and jumpers.
- **Chapter Five** - Pertains to the firmware Setup and preparation procedures to calibrate and operate the instrument.
- **Chapter Six** - Provides Calibration instructions.
- **Chapter Seven** - pertains to the Operation of the HI 2110WI.
- **Chapter Eight** - Pertains to the Troubleshooting procedures for repair of the instrument.

Description

The HI 2110WI is a compact, multipurpose, microprocessor based weight Controller. (See Fig. 1-1) The controller is used for a wide variety of process weighing applications including batching, blending, check weighing, filling/dispensing, force measurement, level by weight and weight rate monitoring. The HI 2110WI can transmit data via analog, serial or BCD communications. Data is displayed alpha-numerically on the six digit fourteen segment LED display. Weight values can be based on either Net, Gross, weight values in pounds or kilograms. An optional Allen Bradley Remote I/O and PROFIBUS interface is available for communication to programmable logic controllers. The 20 bit analog to digital converter in the weight controller updates twenty (20) times per second and is capable of 985,000 counts of display resolution. This gives the instrument the ability to tolerate large "dead"

loads, over sizing of load cells/sensors and still have sufficient resolution to provide accurate weight measurement and control. Commands can be entered into the instrument from the communication ports or locally from a tactile feel sixteen button front panel keypad. A portion of the keys can be locked out to limit operator access and protect data. A limited number of commands can be entered through a rear Remote Functions connector.

WAVERSAVER®

Typically, mechanical noise (from other machinery in a plant environment) is present in forces larger than the weight forces trying to be detected. The HI 2110WI is fitted with WAVERSAVER® technology which eliminates the effects of vibratory forces present in all industrial weight control and measurement applications. By eliminating the factor of vibratory forces the controller is capable of identifying the actual weight data. WAVERSAVER® enables the weight controller to distinguish between actual weight data and mechanical noise, both of which are typically transferred to the weight controller by the load cell signal. WAVERSAVER® can be configured from the front panel to ignore noise with frequencies as low as 0.25 Hz. One of four higher additional cut off frequencies may be selected to provide a faster instrument response time. The default factory configuration is 0.50 Hz vibration frequency immunity.

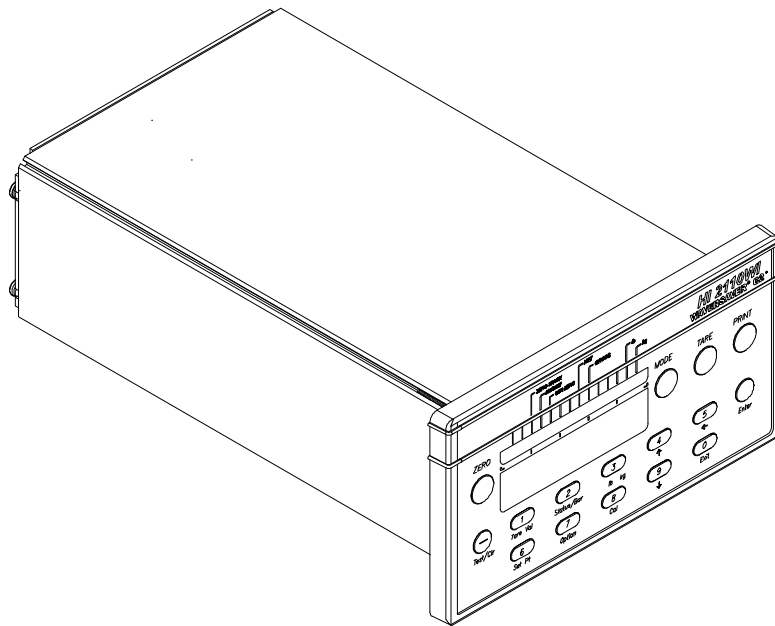

FIG. 1-1 WEIGHT CONTROLLER

C2® Calibration

C2 Second Generation Calibration enables a scale system to be calibrated electronically without using certified test weights which equals the systems load capacity. A C2 weighing system consists of up to eight load sensors, a junction box, interconnect cable and an instrument with C2 capabilities, such as the HI 2110WI. All Hardy Instruments C2 cer-

tified load sensors contain digital information detailing its unique performance characteristics. The HI 2110WI reads the performance characteristics of each individual load sensor and detects the quantity of load sensors in the system. Calibration is performed by simply adding a reference point from the front panel. The reference can be zero (no weight on the scale) or some known weight on the scale. The instrument is also capable of performing traditional calibration such as with the use of certified test weights.

Secure Memory Module (SMM)

The Secure Memory Module stores critical configuration, calibration and setup data of the HI 2110WI thereby protecting this information from corruption. During system operation when a new parameter is entered, the SMM automatically updates that value in its memory. Data stored in one HI 2110WI may be restored in another by physically transferring the SMM to the new instrument. The SMM is conveniently accessible from the instruments rear panel.

NOTE:

You cannot transfer the SMM from the HI 2110WI to the HI 2151/20WC.

Remote Functions

Rear panel input of a level or momentary grounding that can Tare the instrument., force the Net mode, toggle between pounds or kilograms and freeze the front panel display or one of the communications ports. This is useful for adding large additional industrialized switches to the control panel.

Auto Zero Tracking

Auto Zero Tracking will cause the display to indicate zero, as long as any "live weight" on the scale is below the set zero tolerance and the scale is not in weight motion. This capability allows the instrument to ignore material build-up in the weigh system within the set zero tolerance. Auto Zero Tracking is enabled when switch eight of S3 (the configuration dipswitch), labeled Config on the instrument's rear panel is in the on position.

Output Device Options

Analog Output (-B1)

The Analog Output is configured from the front panel and set up by jumpers on the printed circuit card. The option allows the transmission of Gross and Net weight as 0-5V, 0-10V, 0-20mA or 4-20mA (or the reverse of these), and makes it possible to span these ranges over a portion of the weight data. Resolution is 16,000 counts, or the number of display counts available in the range selected, whichever is less. Both voltage and current data are available simultaneously.

Binary Coded Decimal (BCD) Output (-B2)

This BCD Option provides six digits of parallel weight data representing Net, Gross, Tare and the present front panel display. If all types of output data are requested, they will appear one after the other, ten milliseconds apart. The BCD option provides a 37 pin D-subminiature connector on a 6 inch cable.

HI 2110WI WEIGHT CONTROLLER

Binary Coded Decimal (BCD) Output (-B5) This BCD option provides six digits of parallel weight data representing Net, Gross, Tare and The Present Front Panel Display. If all types of output data are requested, they will appear one after the other, ten milliseconds apart. The BCD option provides a 40 pin connector on a 60 inch cable for use with either the optional -B6 or -B7 external termination boards.

BCD Single Termination Card (-B6) The BCD Single Termination Card is an optional external interface point for a single BCD port signal line. The card is designed for use with a single HI-2151/30WC-B5 instrument.

BCD Quad Termination Card (-B7) The BCD Quad Termination Card is an optional external interface point for up to four sets of BCD port signal lines. All terminal positions accept 20 to 26 gauge cable sizes. Additional terminal boards may be interconnected to allow multiple BCD ports to exist in a tri-state arrangement.

Remote I/O (RIO) Interface to the Allen-Bradley Network (-B8) The RIO port allows bi-directional communications with Allen-Bradley Programmable Logic Controllers (PLC) and Small Logic Controllers (SLC). The HI 2110WI represents a quarter rack of discrete I/O (32 bits in the Logic Controllers output and input image files) to the Logic Controller and supports both discrete and block transfers of data. It can support up to 230.4 Kbaud transfer rates.

Binary Coded Decimal (BCD) Output (-B9) This option provides six digits of parallel weight data representing Net, Gross, Tare and the present front panel display. If all types of output data are requested, they will appear, one after the other, ten milliseconds apart. This option provides a 24 inch cable.

PROFIBUS Interface Option (-B12) Allows bi-directional communications to Profibus (Process Fieldbus) products including those made by Siemens, GE Fanuc and Texas Instruments. This interface supports PROFIBUS-DP (Decentralized Periphery) and processes both Selectable Predetermined and Block transfer commands. It supports up to 12 Mbaud transfer rates.

Miscellaneous Options

1240 VAC 50/60 Hz Input Voltage (-E2) This is a factory configuration only.

CHAPTER 2 - SPECIFICATIONS

SCOPE

Chapter Two lists the specifications for the HI 2110WI weight controller. Specifications are listed for the standard instrument and for instruments fitted with optional equipment. The specifications listed are designed to assist in the installation, operation and troubleshooting of the instrument. The service personnel should be familiar with this section before attempting an installation or repair of the instrument.

HI 2110WI Specifications for a Standard Instrument

Conversion Rate	<ul style="list-style-type: none"> • 20 updates per second
Resolution	<ul style="list-style-type: none"> • Displayed: 1:985,000 (@ 3 mV/V) • 1:656,000 (@ 2 mV/V) • Internal: 1:1,048,576
Excitation Voltage	<ul style="list-style-type: none"> • 0-5 VDC
Averages	<ul style="list-style-type: none"> • 1 to 200 User Selectable in single Increments
Input	<ul style="list-style-type: none"> • Up to four (4) 350 ohm Full Wheatstone Bridge, Strain Gauge Load Sensors/Cells (5 volt excitation) on one vessel. • Signal Voltage Range 0-15mV
Display	<ul style="list-style-type: none"> • 6 digit, 14 segment red LED, 0.6" alpha-numeric
Display Increments (Graduations)	<ul style="list-style-type: none"> • 1,2,5,10,20,50,100,200,500 user selectable via the front panel key pad. • Corresponding weight is dependent on the decimal point location.
Key Pad	<ul style="list-style-type: none"> • 16 tactile keys • 6 dedicated functions • 10 dual numeric and function
Non-Linearity	<ul style="list-style-type: none"> • 0.0015% of Full Scale
Maximum Zero Tolerance	<ul style="list-style-type: none"> • 32766
WAVERSAVER®	<ul style="list-style-type: none"> • 7.5 Hz • 3.5 Hz • 1.0 Hz • 0.5 Hz • 0.25 Hz
Approvals	<p>UL CE</p>

HI 2110WI WEIGHT CONTROLLER

Power and Utility Requirements

- | | |
|----------------------------------|---|
| Voltage | <ul style="list-style-type: none">• 120 VAC \pm 10% Standard• 240 VAC \pm 10% (-E2 Factory Option) |
| Frequency | <ul style="list-style-type: none">• 47/63 Hz |
| Power | <ul style="list-style-type: none">• 10 Watts maximum with options |
| Common Mode Voltage Range | <ul style="list-style-type: none">• \pm 2.5 VDC |
| Common Mode Rejection | <ul style="list-style-type: none">• 100dB @ 50-60Hz |
| Approvals | UL
CE |

Environmental Requirements

- | | |
|------------------------------------|--|
| Operating Temperature Range | <ul style="list-style-type: none">• -10 to 50 C (14 to 122 F) |
| Storage Temperature Range | <ul style="list-style-type: none">• -20 to 85 C (-4 to 185 F) |
| Temperature Coefficient | <ul style="list-style-type: none">• Less than 0.005% of full scale per degree C for zero and span. |
| Humidity Range | <ul style="list-style-type: none">• 0-90% (non-condensing) |

Physical Characteristics

- | | |
|--|---|
| Panel Mount (Model # HI 2110WI) | <ul style="list-style-type: none">• Depth
11.35" (288.29mm) Back of the Bezel to rear cable clearance.• Case Dimensions
2.99"H x 5.65"W x 9.02"D (75.9mmH x 143.51mmW x 229.11mmD)• Front Panel Dimensions
3.74"H x 7.00"W x 0.42"D (95mmH x 177.80mmW x 10.67mmD)• Panel Cutout Dimensions
3.09"H x 5.75"W (78.5mmH x 146mmW) |
|--|---|

- Case Material
Aluminum alloy (6063-T5), Chem. Film (MIL-C-541)
- Weight
4.6 pounds (2.1 Kilograms)
- Rating
Front Panel NEMA 4 Seal

**Remote Mount
Model HI 2110WI-RM**

- Case Dimensions
3.23"H x 5.74"W x 10.40"D (82.04mmH x 145.8mmW x 264.2mmD)
- Front Panel Dimensions
3.74"H x 7.00"W x 0.42"D (95mmH x 177.8mmW x 10.67mmD)
- Panel Cutout Dimensions
3.09"H x 5.75"W (78.4mmH x 146mmW)
- Weight
4.6 pounds (2.1 Kilograms)
- NEMA Ratings
Case None
Front Panel NEMA 4 seal
- Cable
5 foot flat ribbon

Optional Equipment

Analog Output (-B1)

- Resolution
16,000 counts
- Linearity
0.01% (with 1 average selected)
- Response Time
1 millisecond after update
- Isolation from Main Board

300 VAC or 450 VDC

- Update

50 milliseconds (20 times/sec.)

- Voltage Out

Range

0 - 5 VDC, 0-10 VDC (or reverse of these)

Max Current

5 ma (2 K ohm load @ 10 V)

Temp. Stability

10 ppm/C or 4 mV total from 30 degrees F to 120 degrees F

- Current Out

Range

0 - 20 mA, 4-20 mA (or reverse of these)

Max Voltage

12 V allowing 0 - 600 ohm load at 20 mA

Mating Connector

6 pin Phoenix

**Binary Coded
Decimal (BCD) (-B2)**

- Resolution

6 digits

- Data Drive

15 LSTTL loads (6 mA total)

- Print/Not Print Drive

10 LSTTL loads (4 mA)

- Transmit Distance

50 feet (15.24 meters)

	<ul style="list-style-type: none">• Cable 6" 40 pin right angle to 37 pin Dshell Connector. Use with -B6 and -B7 Options
Binary Coded Decimal (BCD) (-B5)	<ul style="list-style-type: none">• Resolution 6 digits• Data Drive 15 LSTTL loads (6 mA total)• Print/Not Print Drive 10 LSTTL loads (4 mA)• Transmit Distance 50 feet (15.24 meters)• Cable 60" - 40 pin right angle to 40 pin right angle. Use with -B6 and -B7 Options
BCD Single Termination Board (- B6)	<ul style="list-style-type: none">• Overall Dimensions 7.75L" x 5.0W" (196.85mmL x 127.00mmW)• TB Wire Gauge 20 to 26 AWG
BCD Quad Termination Board (- B7)	<ul style="list-style-type: none">• Overall Dimensions 7.5L" x 5.0W" (196.85mmL x 127.00mmW)• TB Wire Gauge 20 to 26 AWG
Allen-Bradley Remote I/O Interface (-B8)	<ul style="list-style-type: none">• Resolution 986,000 counts• Represents 1/4 Rack of Discrete I/O

**Binary Coded
Decimal (BCD) (-B9)**

- Type Transfers
Discrete and Block (Read & Write)
- Baud Rate
57.6 Kbaud
115.2 Kbaud
234.4 Kbaud
- Resolution
6 digits
- Data Drive
15 LSTTL Loads (6mA Total)
- Print/Not Print Drive
10 LSTTL Loads (4mA)
- Transmit Distance
50 feet (15.24 meters)
- Cable
24" For use with -WS Wall Mount Instrument

**Profibus I/O
Interface (-B12)**

- Protocol
DP (Decentralized Periphery)
- Data Configuration
16 words or 32 bytes
- Standard Reference
Process Fieldbus - DIN 19 245
- Baud Rate
9,600 Kbaud to 12 Mbaud (Auto-Selectable)

CHAPTER 3 - INSTALLATION

SCOPE

All information contained in Chapter 3 pertains to unpacking, cabling, interconnecting and installing the HI 2110WI weight controller. Alternatives to any specifications contained or implied in this section are not recommended. It is very important that the user and service personnel be familiar with the procedures contained in this chapter, before installing or operating the HI 2110WI weight controller.

Unpacking

- Before signing the packing slip, inspect the packing for damage of any kind.
- Report any damage to the carrier company immediately.
- Check to see that everything in the package matches the bill of lading. You should normally have:

1. HI 2110WI Panel Mount

- (1) HI 2110WI instrument with mating connectors and ordered options installed.
- (1) Mounting Rail Kit (Prt. # 0551-0287-01)
 - (4) Mounting Rails
 - (4) 6-32 UNC Phillips pan head machine screws

2. HI 2110WI-RM Remote Mount

- (1) Instrument with mating connectors and ordered options installed.
 - (1) Remote display/keypad with gasket and mounting hardware attached.
 - (1) 60 inch display to instrument interconnect ribbon cable.
 - (1) Installation and Operation Manual
- If any items are missing, damaged, or there are any questions, please contact your local Customer Support Center.
 - Record the model number and serial number of the Weight Controller. Store in a convenient, secure location for reference when contacting your Customer Service Department or to buy parts or firmware upgrades.

Mechanical Installation

Installing the HI 2110WI in a Panel

- Panel Cutout Specifications
 - 1. Enclosure Size Requirements.
 - a. Overall depth of the enclosure must be a minimum of 11.5" to allow for the 2" clearance between the rear panel of the

HI 2110WI and the inside surface of the rear panel of the enclosure. (See Fig. 3-1)

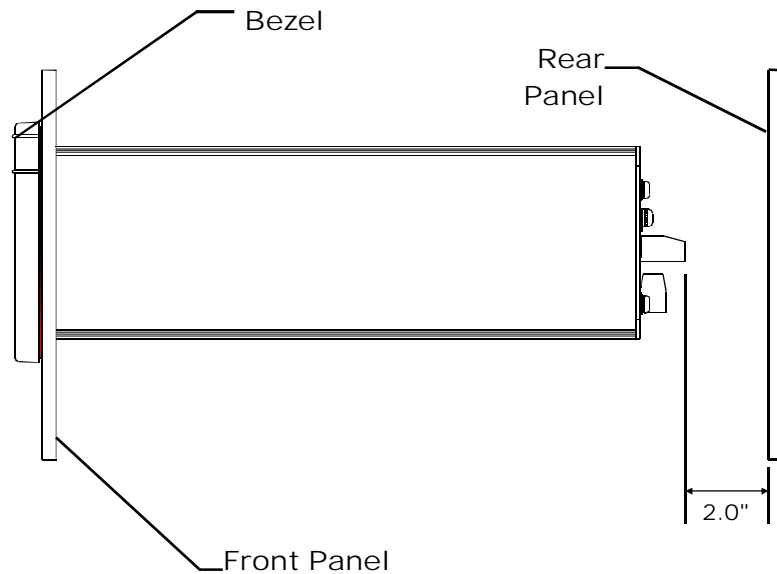

FIG. 3-1 2" REAR PANEL CLEARANCE REQUIREMENT

- b. There must be a 1" clearance completely around the bezel and other installed units.
2. Dimensions of the enclosure cutout (See Fig. 3-2)
 - a. 5.75" \pm .06 (146.05mm \pm 1.52) Wide
 - b. 3.09" \pm .06 (78.49mm \pm 1.52) High
 - c. All cutout surfaces must be deburred before installation of the controller.

WARNING

DO NOT MOUNT THE HI 2110WI CONTROLLER NEAR A HIGH MAGNETIC FIELD OR HIGH VAC POWER SOURCE. TO DO SO WILL EFFECT THE PERFORMANCE OF THE CONTROLLER AND MAY RESULT IN PROPERTY DAMAGE.

Installing the HI 2110WI Panel Mount

- Step 1. Make sure that all Electrostatic Discharge (ESD) precautions have been taken, before installation.
- Step 2. The controller comes with a NEMA 4 rated compression gasket. Make sure the gasket is properly seated in the bezel before installation.
- Step 3. Gently slide the controller into the cutout in the enclosure. Be sure to secure the controller with both hands when installing.

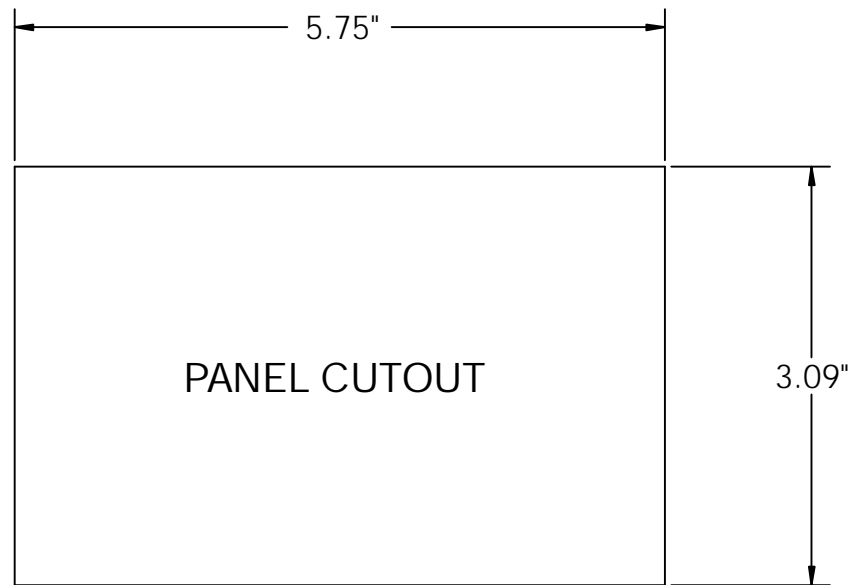

FIG. 3-2 PANEL CUTOUT DIMENSIONS

- Step 4. Slide the controller into the panel cutout until the NEMA 4 & 4X gasket is flush against the front panel of the enclosure.
(See Fig. 3-3)

CAUTION

ONCE THE GASKET IS COMPRESSED IT SHOULD NOT BE USED AGAIN. WHENEVER THE CONTROLLER IS REMOVED FROM THE PANEL, RE INSTALL WITH A NEW GASKET. (HARDY PRT. # 0524-0011)

- Step 5. Install the four (4) mounting bars.
- Slide each of the mounting bars into the slots at the rear of the controller.
 - One end of the mounting bar is recessed. Make sure you install the bars from this end.
 - Check to be sure the mounting bars are flush against the inside surface of the front panel.

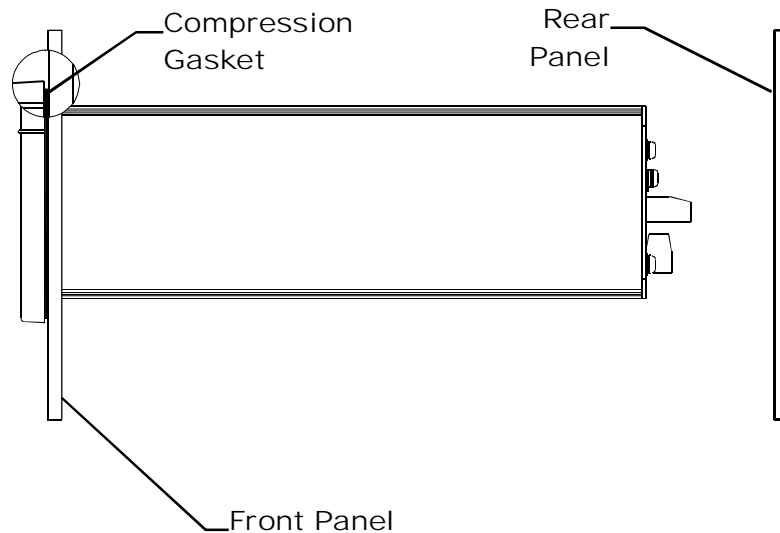

FIG. 3-3 NEMA 4 GASKET FLUSH AGAINST THE FRONT PANEL

- Step 6. Install the four (4) 6-32 pan head machine screws into the threaded slots at each corner of the controller.
- Step 7. Hold the controller so that it is aligned and flush against the enclosure front panel throughout the entire tightening process.
- Step 8. Facing the rear panel of the controller, tighten each screw in a clockwise direction from corner to corner until each screw is finger tight.
- Step 9. Using a phillips screw driver, continue the clockwise direction and partially tighten each screw until the NEMA 4 bezel gasket is completely compressed and the bezel is flush against the front panel of the enclosure. Do not tighten one screw down completely and then go on to the next screw. Each screw must be tightened a little before going on to the next to maintain the alignment between the controller and the front panel of the enclosure.

CAUTION

DO NOT OVER TIGHTEN THE MACHINE SCREWS. OVER TIGHTENING CAN DEFLECT THE BEZEL SO THAT IT WILL NOT BE WATER TIGHT AND/OR BREAK OFF THE CORNERS OF THE BEZEL.

- Step 10. The Panel Mount installation is complete.

Installing the HI 2110WI Remote Mount Model

NOTE:

See Fig. 3-2 for information about the panel cutout.

Installation of the Front Panel

- Step 1. Make sure that all Electrostatic Discharge (ESD) precautions have been taken, before installation.

- Step 2. The controller comes with a NEMA 4 rated compression gasket. Make sure the gasket is properly seated in the bezel before installation.
- Step 3. The front panel comes with two (2) mounting brackets mounted on the bezel.
- Step 4. Remove the nuts that fasten the brackets to the bezel. Remove the brackets.
- Step 5. Gently slide the front panel into the enclosure cutout until the gasket is seated against the front of the enclosure. (See Fig. 3-4)

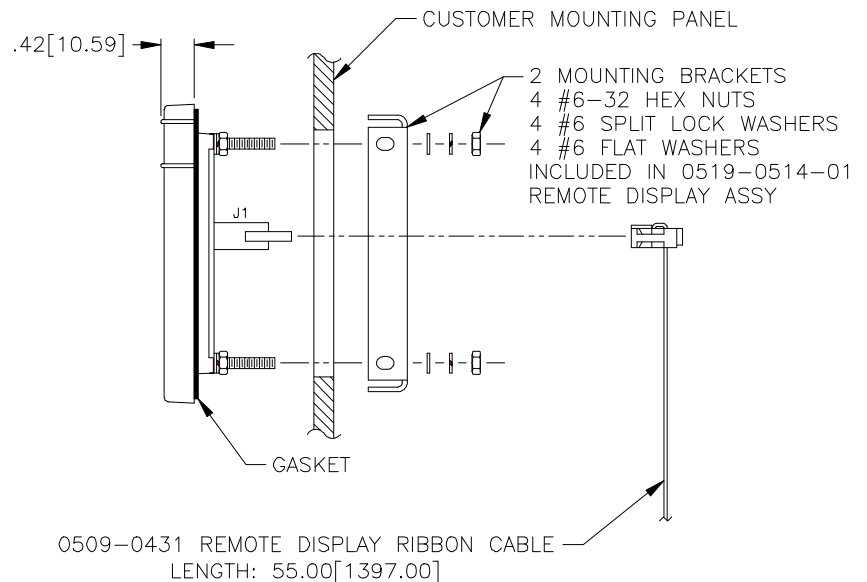

FIG. 3-4 MOUNTING REMOTE DISPLAY TO CUSTOMER'S ENCLOSURE

NOTE:

The nuts on the mounting studs barely clear the cutout. It might take a little adjusting to get the bezel into the cutout.

- Step 6. Place the brackets, #6 flat washer, lock washer and hex nut on the four (4) bezel studs.
- Step 7. Make sure that the bezel is centered in the cutout.
- Step 8. Tighten the #6 hex nuts finger tight in turn.
- Step 9. Use a nut driver or box end wrench and tighten the nuts in turn so that the bezel is flush against the front surface of the enclosure front panel.

CAUTION

DO NOT OVER TIGHTEN. OVER TIGHTENING CAN DEFLECT THE BEZEL SO THAT IT WILL NOT BE WATER TIGHT AND/OR BREAK OFF THE CORNERS OF THE BEZEL.

Installation of the Instrument Enclosure

- Step 1. Drill four (4) .156 inch tapped or thru holes and use four (4) 6-32 pan head machine screws to fasten the instrument enclosure to a panel. (See Fig.3-5)

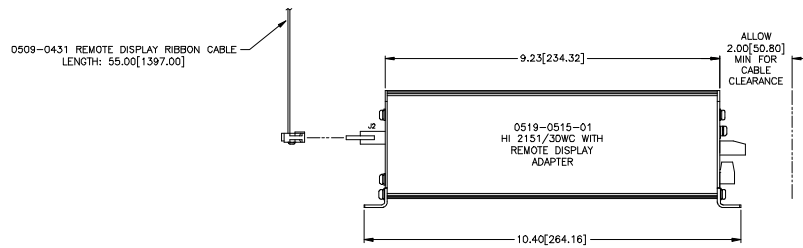
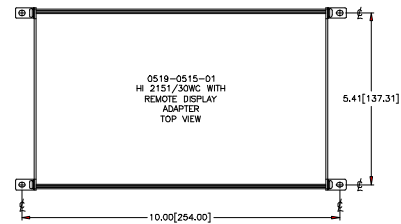

FIG. 3-5 INSTALLING ELECTRONICS ENCLOSURE TO A PLATE

- Step 2. Connect the 60 inch, 40 pin ribbon cable to the 40 pin connection J5 on the electronics and the 40 pin connection J4 at the rear of the front panel display.
- Step 3. Remote panel mechanical installation is complete.

NOTE:

The electronics can be mounted on any of the four sides.

WARNING

DO NOT MOUNT THE HI 2110WI CONTROLLER NEAR A HIGH MAGNETIC FIELD OR 120 VAC POWER SOURCE. ROUTE RIBBON CABLE A MINIMUM OF 3 INCHES FROM ANY AC VOLTAGE CONDUCTING CABLES. TO DO SO WILL EFFECT THE PERFORMANCE OF THE CONTROLLER AND MAY RESULT IN PROPERTY DAMAGE.

Electrical Installation

Cabling and Interconnecting

Recommended Installation Procedures

- Step 1. Carefully plan the cable runs and wiring connections before routing, cutting and trimming cables and wires.

CAUTION

INSTRUMENT POWER AND RELAY WIRES SHOULD BE ROUTED AWAY FROM ALL OTHER SIGNAL CABLES TO AVOID ELECTRICAL INTERFERENCE.

- Step 2. All cabling should be neatly bundled, tied, and dressed.
- Step 3. Use a 6 inch service bend to relieve stress on the connectors and to ease servicing the unit.
- Step 4. Make sure that all plugs are firmly in place.

- Step 5. Be sure to secure the power cord with the two (2) captive screw-on clips.
- Step 6. All connections are made at the rear panel of the weight controller.

Input Power Wiring

WARNING

DO NOT OPERATE WITH INCORRECT LINE VOLTAGE. TO DO SO WILL RESULT IN PROPERTY DAMAGE OR PERSONAL INJURY. CHANGING THE INPUT VOLTAGE RATING BETWEEN 120 AND 240 VAC REQUIRES MODIFICATIONS TO THE POWER/RELAY CIRCUIT BOARD AND RELAY OUTPUT BOARD. THIS PROCEDURE SHOULD ONLY BE DONE BY AUTHORIZED PERSONNEL. FOR FURTHER ASSISTANCE CONTACT HARDY INSTRUMENTS, CUSTOMER SUPPORT.

- Step 1. The HI 2110WI is factory configured to operate from either 120 or 240 VAC, 50 or 60 Hz power. Check the model number of your unit to verify the voltage. If the unit is configured for 240 VAC, an "E2" will be printed on the name plate.
- Step 2. The power filters and conditions AC power. However, for noisy power lines, external conditioning may be required. Contact your Customer Support center for more information.
- Step 3. The AC power should be supplied by a "clean" primary line, directly from the power panel. This line should not supply any other equipment, including the feeding unit, and should be supplied with a minimum 10 amp breaker.
- Step 4. To connect power to the controller, install a 3-wire, minimum of a 14 AWG power line to the 3-pin terminal block connector. (See Fig. 3-6)
- Step 5. Fuse: .5 AMP, 250 VAC Slow-Blow 3AG, located behind J6 on the power relay printed circuit board.

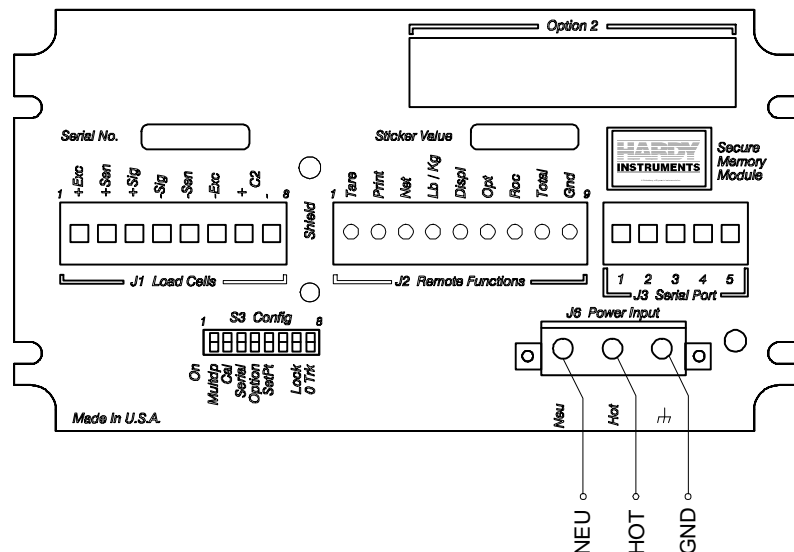

FIG. 3-6 POWER WIRING DIAGRAM

Step 6. Power Input J6

- J6 - 1 Neu (Low)
- J6 - 2 Hot (HI)
- J6 - 3 (Ground)

Remote Functions Wiring

Step 1. Some functions are level conditions and some are activated by momentary grounding. Both use the remote functions ground found on pin 9.

- Wire Size:
22 AWG Min. to 12 AWG Max. Shielded
(Requires Optional Mating Connector)

Step 2. Momentary Functions require 100 mSEC or greater contact to ground for proper activation. Use remote functions ground only for activating remote functions.

CAUTION

REMOTE FUNCTIONS ARE NOT ISOLATED. DO NOT BUNDLE WIRING FROM REMOTE FUNCTIONS WITH POWER CABLE, RELAY CABLE OR WITH ANY OTHER HIGH ENERGY CABLES. USE SHIELDED CABLE ONLY. TO DO SO MAY RESULT IN UNSTABLE PERFORMANCE.

Load Cell/Point Connections (J1)

1. The unit is capable of powering a maximum of four 350 ohm load cells/points. If more than four load cells/points are used, an external power supply is required. Figures 3-9, 3-10, Load cell/point connections (J1) shows how to connect a full six-wire hookup, a four-wire hookup, and an external excitation supply. Load cell/point cables are connected to J1 through a furnished mating plug, P1.

NOTE:

Contact your Customer Support Center for installation information when using an external power supply.

2. In order to ensure a "clean" signal from the load cells/points, the following precautions should be taken:
 - Load cell/point cables **MUST** be run separate from all other cables and in their own conduit. Load cell/point cable shield should be attached to ground screw on rear panel only.
 - Six-wire, shielded load cell/point cable should be used for lengths of 50 feet or more, or if intrinsic safety barriers are used. Eight-wire for C2 calibration.
 - Avoid load cell/point cable splices. If cables are longer than needed, coil up and tape excess cable. If cables are short, use an appropriate junction box. When terminal lugs are installed on load cell/point cables, Hardy Instruments recommends the lug be crimped and soldered.

- When connecting the HI 2110WI weight controller to the HI 215IT junction box using C2 load cell/point cable (6020-0001), use the following color code:

Model	EXC+	SEN+	SIG+	SIG-	SEN-	EXC-	C2+	C2-
J-BOX	RED	BLUE	GRN	WHT	BROWN	BLK	GREY	VIO

TABLE 3-1: C2 CABLE COLOR CODE

WARNING

DO NOT OPERATE AT INCORRECT LINE VOLTAGE; THE UNIT WILL BE DAMAGED. CHANGING THE INPUT VOLTAGE RATING BETWEEN 120 VAC AND 240 VAC REQUIRES MODIFICATIONS AT THE FACTORY. FOR FURTHER HELP CONTACT CUSTOMER SUPPORT.

C2 Load Cell Connections (J1)
(See Fig. 3-7)

- Step 1. Attach load cell cable shield under screw near J1 on back of weight controller.
- Step 2. Factory installed jumpers to be removed for C2 wire load cell connection.
- Step 3. Do not run load cell cable in parallel with or in same conduit with power wiring, relay cables or any other high energy cables.
- Step 4. Recommend load cell cable, Hardy Instruments (Prt. # 6020-0001)

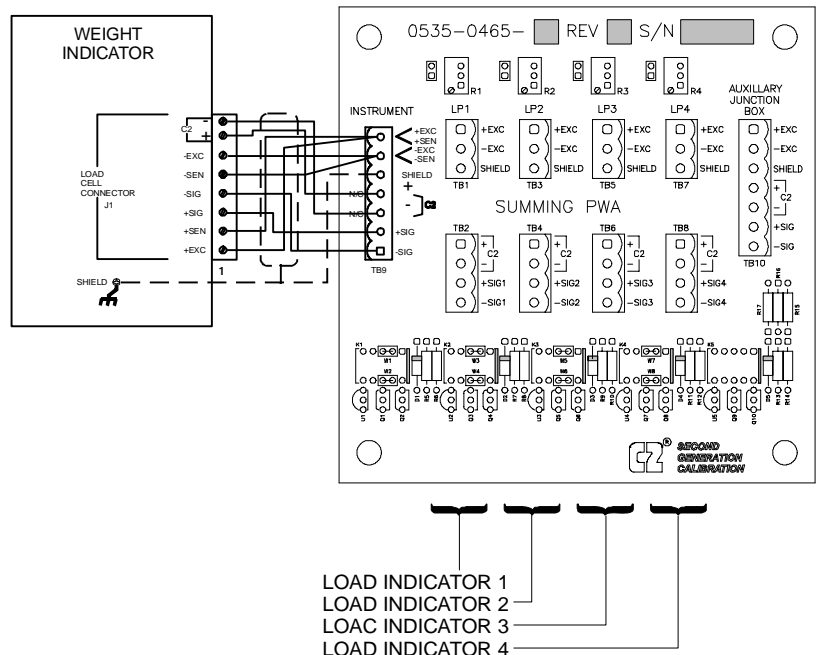

FIG. 3-7 C2 LOAD CELL CONNECTION

Non C2 Load Cell Connections (J1)
(See Fig. 3-8)

- Step 1. Attach load cell cable shield under screw near J1 on back of weight controller.
- Step 2. Factory installed jumpers to remain in place for 4 wire load cell connection.

- Step 3. Do not run load cell cable in parallel with or in same conduit with power wiring, relay cables or any other high energy cables.
- Step 4. Eight (8) conductor load cell cable required when:
 - Cable runs greater than 50 feet.
 - With Soft Calibration.

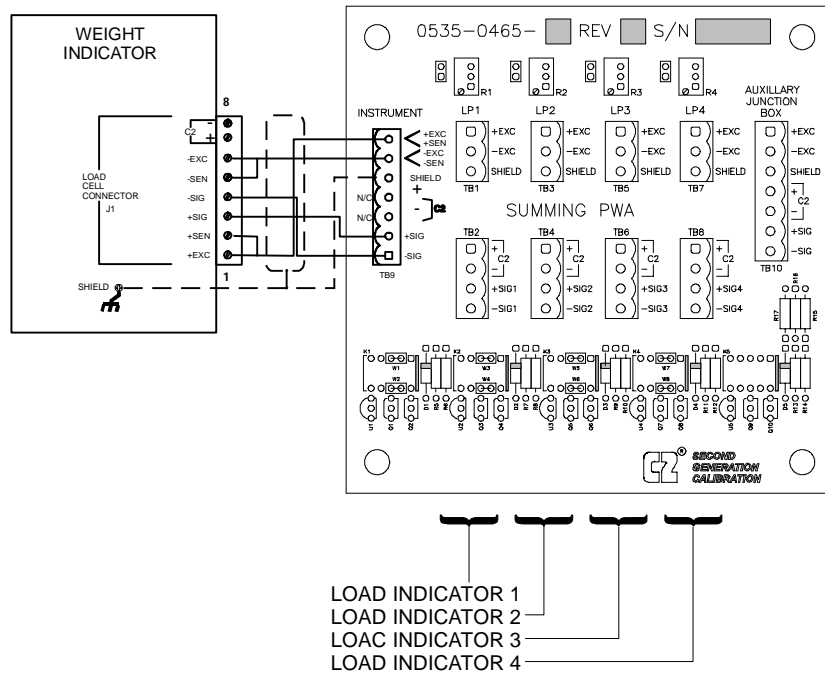

FIG. 3-8 LOAD CELL CONNECTION (NON C2 LOAD CELLS) J1

**Non C2 Load
Sensor Connections
(J1)**

- Step 1. Attach load cell cable shield under screw near J1 on back of weight controller.
- Step 2. Factory installed jumpers to be removed for 6 wire load cell connection.
- Step 3. Do not run load cell cable in parallel with or in same conduit with power wiring, relay cables or any other high energy cables.

NOTE:

Contact your local Customer Support Center for installation information when using an external power supply.

NOTE:

Record all load cell serial numbers and location on the label located on the inside cover of the junction box.

**OUTPUT OPTION
BOARD INSTALLATION
PROCEDURES**

WARNING

DANGEROUS VOLTAGE IS PRESENT WITHIN THE ENCLOSURE OF THE INSTRUMENT AND PRESENTS A RISK OF ELECTRICAL SHOCK.

ALWAYS UNPLUG THE POWER CORD BEFORE OPENING AND SERVICING THE INSTRUMENT.

CAUTION

INSTALLATION AND SERVICING OF THIS UNIT SHOULD BE PERFORMED BY AUTHORIZED AND QUALIFIED SERVICE PERSONNEL ONLY. FOLLOW ALL ELECTROSTATIC DISCHARGE (ESD) PROCEDURES WHEN OPENING THE INSTRUMENT.

- Step 1. Disconnect the power cord.
- Step 2. Detach all interconnect cabling.
- Step 3. Use a phillips screw driver and remove the four (4) pan head machine screws that fasten the rear panel to the extrusion.
- Step 4. Gently pull out the rear panel with the printed circuit boards attached. The main board is in clear view
- Step 5. The Option Board is furnished with four mounting screws to secure it to the main board. The main board has pre-mounted standoffs which accept any of the Option Boards. (See Fig. 3-9)

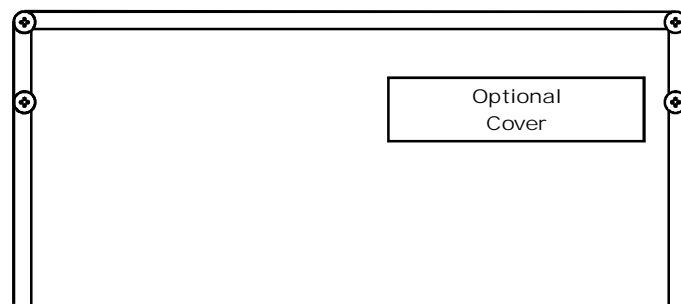

FIG. 3-9 OPTION LABEL COVER

NOTE:

Pin number 1 will always be on the left side of the unit (when facing the rear panel) except for the parallel BCD board.

- Step 6. Position the Option Board over the standoffs and carefully align the mating connector pins of the Option Board with the appropriate socket position, J4 or J5, on the main board. Make sure that the connector pins are guided straight into the socket.
- Step 7. Push down on the option board to seat the option connector pins into the socket on the main board. Visually verify that all of the pins have been properly seated into the mating connector.
- Step 8. With the option board resting on top of the four (4) standoffs fastened to the main board, install the four (4) screws, lock washers and flat washers.
- Step 9. Gently slide the rear panel back into the extrusion
- Step 10. Replace the four (4) pan head machine screws that fasten the rear panel to the extrusion.
- Step 11. Connect the power cord.

Options Cabling and Interconnect

Analog Output
Option -B1 (See
Fig. 3-10)

1. The Analog Output Option card can be mounted in the option slot.
2. This option has one output connector and uses pins 1 and 2 for + and - voltage outputs and pins 5 and 6 for - and + current outputs.
3. One current and voltage range is selected by configuring the two jumpers on jumper block "W" of the analog board.

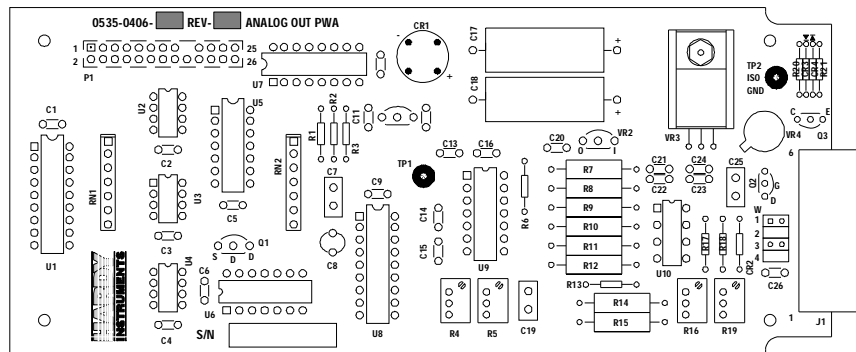

FIG. 3-10 ANALOG OUTPUT BOARD

4. Both current and voltage outputs are available simultaneously.
5. For Jumper Configurations See Chapter 4, Section 4.2.
6. Wire Size:

22 AWG Min. To 12 AWG Max

7. -B1 Option Connector Wiring:

- J1-1 V+
- J1-2 V-
- J1-3 No Connection
- J1-4 No Connection
- J1-5 I-
- J1-6 i+

BCD Option Board
Installation
Procedures -B2, -
B5, -B9

1. The BCD option board. (See Fig. 3-11) is installed in the option slot and will provide parallel output of the sensed gross, net, or tare weight.

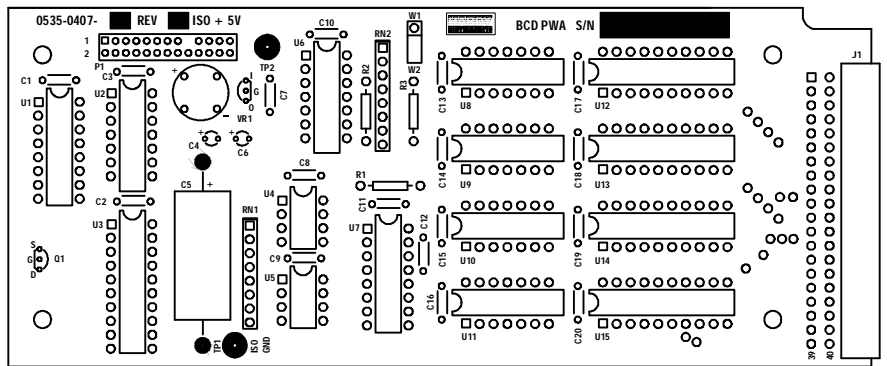

FIG. 3-11 PARALLEL BCD BOARD

2. Connector Requirements

- The board connector is a 40 pin right angle connector terminating to either a 37 pin D-subminiature assembly (option B-2) a 40 pin connector with a 60-inch cable (option B-5), or a 40 pin connector with a 24" cable (option B-9 used with a Wall Mount Model) The B-5 option provides flexibility of terminating BCD signal lines to the terminal board options B-6 and B-7.
- The pin designations for the BCD output are noted in Table 3-1 Cable Pinouts - Parallel BCD Board Connector to BCD Connector. All data outputs have a drive capability of 15 LSTTL loads (6 mA total) and use positive true logic. PRINT/READY has a drive capability of 10 LSTTL loads (4mA). This option board is electrically and optically isolated from the main board.
- Cable Pinouts - Parallel BCD Board Connector to DB Connector

BCD BOARD	DB CONNECTOR	SIGNAL	VALUE
1	1	GND	
3	2	BCD digit 1, bit 0	1 x 10 ⁰
5	3	BCD digit 1, bit 1	2 x 10 ⁰
7	4	BCD digit 1, bit 2	4 x 10 ⁰
9	5	BCD digit 1, bit 3	8 x 10 ⁰
11	6	BCD digit 2, bit 0	1 x 10 ¹
13	7	BCD digit 2, bit 1	2 x 10 ¹
15	8	BCD digit 2, bit 2	4 x 10 ¹

TABLE 3-2: CABLE PINOUTS

BCD BOARD	DB CONNECTOR	SIGNAL	VALUE
17	9	BCD digit 2, bit 3	8×10^1
19	10	BCD digit 3, bit 0	1×10^2
21	11	BCD digit 3, bit 1	2×10^2
23	12	BCD digit 3, bit 2	4×10^2
25	13	BCD digit 3, bit 3	8×10^2
27	14	BCD digit 4, bit 0	1×10^3
29	15	BCD digit 4, bit 1	2×10^3
31	16	BCD digit 4, bit 2	4×10^3
33	17	BCD digit 4, bit 3	8×10^3
35	18	BCD digit 5, bit 0	1×10^4
37	19	BCD digit 5, bit 1	2×10^4
2	20	BCD digit 5, bit 2	4×10^4
4	21	BCD digit 5, bit 3	8×10^4
6	22	BCD digit 6, bit 0	1×10^5
8	23	BCD digit 6, bit 0	2×10^5
10	24	BCD digit 6, bit 0	4×10^5
12	25	BCD digit 6, bit 0	8×10^5
14	26	$\pm (\leq +5V) (\geq 0V)$	
16	27	OVR	
18	28	WEIGHT SELECT - LSB (See Chart 3- 4)	
20	29	<u>WEIGHT SELECT</u> - MSB (See Chart 3- 4)	
22	30	OUTPUT DISABLE	
24	31	Not Used	
26		Not Used	

TABLE 3-2: CABLE PINOUTS

BCD BOARD	DB CONNECTOR	SIGNAL	VALUE
28	33	MOTION (+5V = in motion)	
32		Not Used	
34	36	LB/KG	
36	37	GND	
38-40		Not Used	

TABLE 3-2: CABLE PINOUTS

PIN		MODE
28	29	
0	0	GROSS
0	1	NET
1	0	TARE

TABLE 3-3: WEIGHT MODE

3. BCD Terminator Boards - B6, - B7

- BCD Termination Board Installation Procedures (See Fig. 3-12)

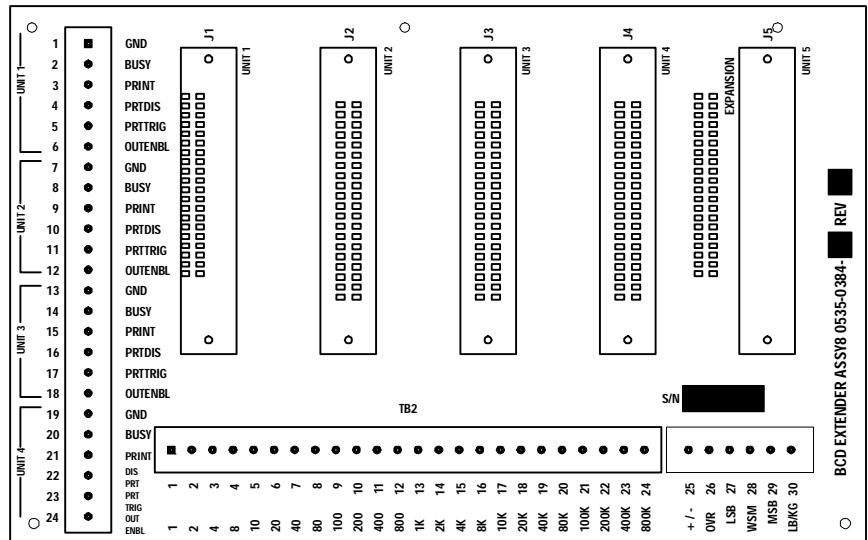

FIG. 3-12 BCD QUAD TERMINATION BOARD OPTION

- Locate a clear, flat mounting area within five feet of all HI 2110WIs.
- Use the measurements shown in Figure 3-13 BCD Termination Board Installation Drill Template Illustration or P/N

0596-0117 drill template to mark five mounting holes. (See Fig. 3-13)

- Drill 3/16-inch holes where marked.
- Install five P/N 2815-0053 standoffs in the holes.
- Install BCD terminal board on standoffs.
- Connect P/N 0509-0389-01 ribbon cables between the BCD output (instrument option slot 2) of up to four HI 2110WIs and BCD terminal board jacks J1 through J4.

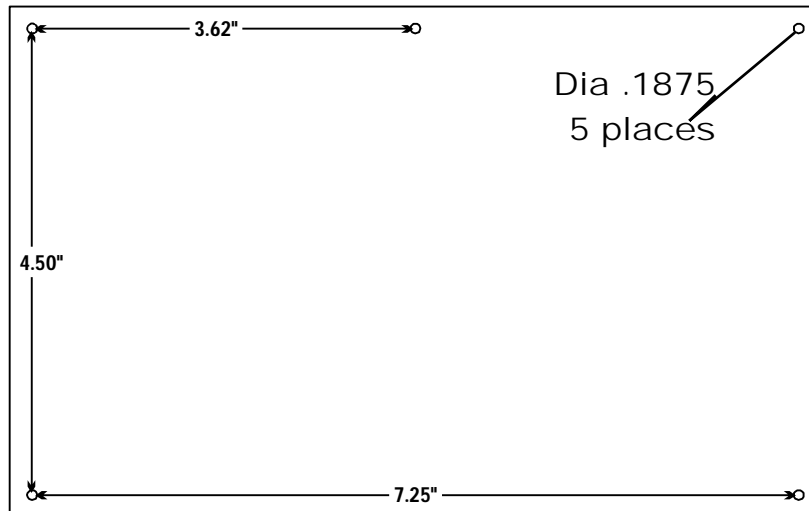

FIG. 3-13 BCD TERMINATION BOARD INSTALLATION DRILL TEMPLATE

- Connect control lines from computer to TB1.
- For installations with more than four HI 2110WIs, proceed as follows:
- Install a second BCD terminal board within two feet of installed BCD terminal board. Refer to steps 1 through 7.
- Connect P/N 0509-0389-02 ribbon cable from J5 on one BCD terminal board to J5 on the other BCD terminal board.
- Connect data/status lines from BCD terminal board to computer. (See Fig. 3-14)
- Wire Size:

26 AWG to 20 AWG

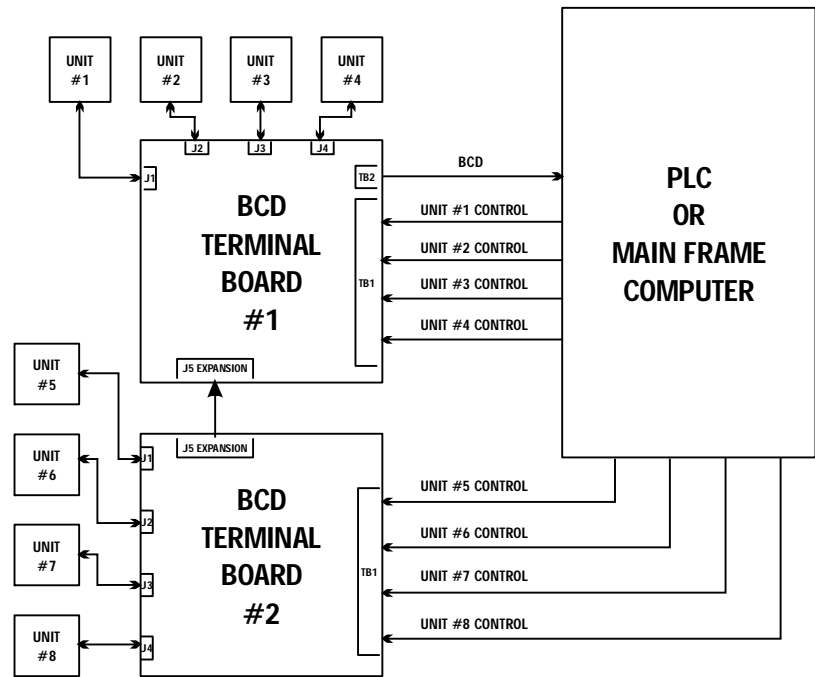

FIG. 3-14 BCD TERMINATION INSTALLATION BLOCK DIAGRAM

4. Allen-Bradley RIO Interface Option -B8

- Refer to Hardy Instruments HI 2151 Series Weight Controllers Remote I/O Installation and Operation Manual, Document Number 0596-0173 for details.
- The Allen-Bradley RIO card can be mounted in either option slot one (1) or option slot two (2). However, there is a limit of one RIO card per instrument.
- Connector Wiring:

- J2-1 Blue (1/2 of twisted pair)
- J2-2 Shield (outer braided cable shield)
- J3-3 Clear (1/2 of twisted pair)
- J4-4 No Connection
- J4-5 No Connection
- J4-6 Wire to instrument chassis ground

5. Profibus Interface Option -B12

- Refer to Profibus Interface Option Manual for the HI 2110WI Installation and Operation details.
- Connector Cable Wiring:

Top Row Right to Left

- J1-1 Ground (outer braided shield)

J1-2 No Connection
J1-3 Transmit (1/2 of twisted pair)
J1-4 No Connection
J1-5 No Connection

Bottom Row Right to Left

J1-6 No Connection
J1-7 No Connection
J1-8 Receive (1/2 of twisted pair)
J1-9 No Connection

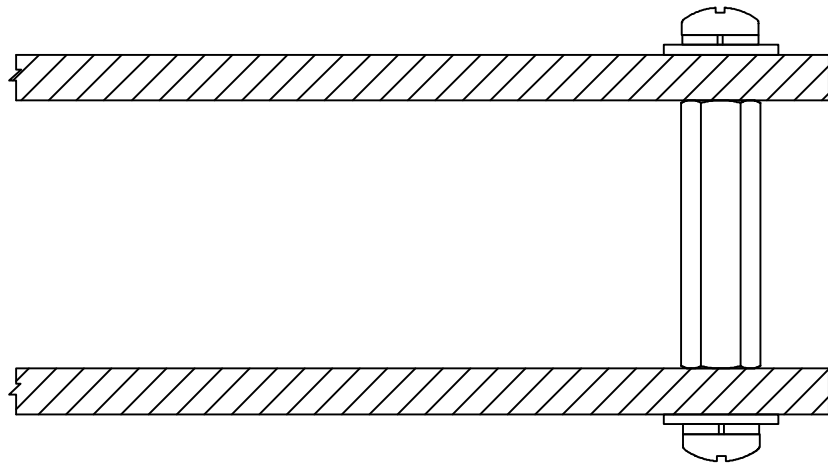

FIG. 3-15 STANDOFF ASSEMBLY

**Profibus Interface
Card Option Wiring
Diagram**

- See the Profibus Interface Option, Card Operation and Installation Manual #0596-0231-01 for complete instructions.

Installation of the Secure Memory Module

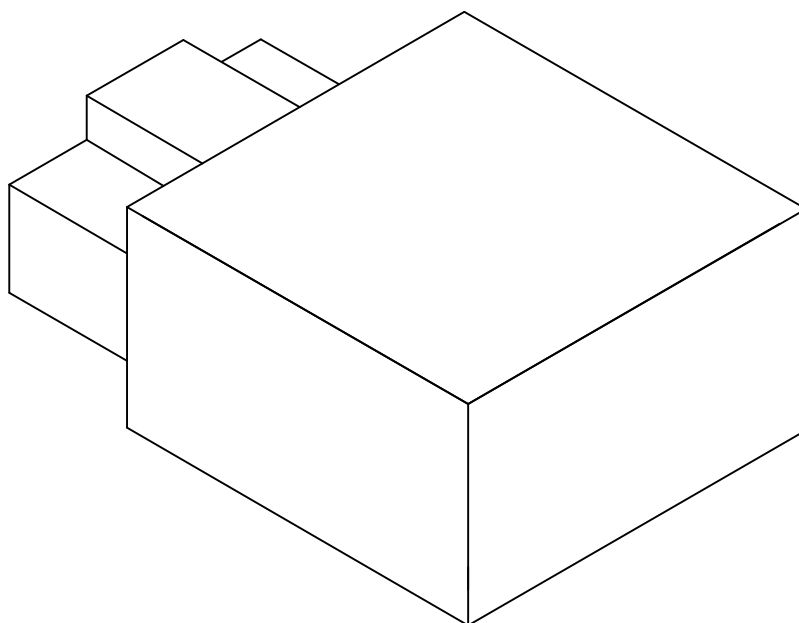

FIG. 3-16 SECURE MEMORY MODULE

- Step 1. Make sure that the module has the notch facing up. (See Fig. 3-16)
- Step 2. Slide the module with the notch up into the module housing.
- Step 3. Press the module in until it stops.
- Step 4. To remove the module pull the module straight out of the housing. (See Fig. 3-17)

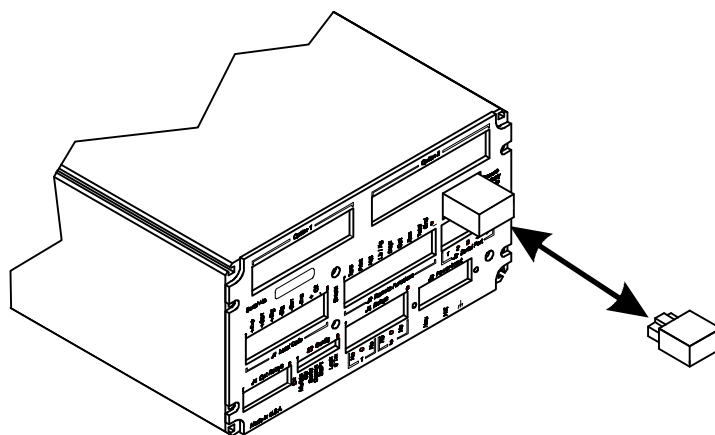

FIG. 3-17 INSTALLING AND REMOVING THE SECURE MEMORY MODULE

CHAPTER 4 - CONFIGURATION

SCOPE

Chapter Four consists of all the procedures for configuring the HI 2110WI Weight Controller. System Configuration includes only hardware adjustments such as Jumper and Dip Switch settings. We recommend that maintenance personnel be familiar with this chapter before configuring the weight controller. Alternative configuration procedures are not recommended.

Analog Output Option Card Configuration Procedures -B1

About the Analog Output Card Option

The analog transmitter outputs to a receiving device (PLC, Computer etc.). The transmitter outputs a user selectable Gross, or Net Weight as 0-5V, 0-10V, 0-20mA, or 4-20mA (via the front panel you can reverse the voltage and current ranges, See Chapter 5 for procedures). When configuring the Analog Output Card, both the receiver and the HI 2110WI must be in the same mode (e.g. Gross or Net Weight). The analog card can also span the voltage or milliamp ranges over a portion of the weight data. The outputs are electrically and optically isolated from the main board. The Analog Output Card is adjusted at the factory. (See Chapter 5, for Setup Instructions)

Setting the Jumpers

Disassembling the Rear Panel and Setting Jumpers

- Step 1. Disconnect the Power Cord.
- Step 1. Remove the four (4) pan head machine screws that fasten the rear panel to the extrusion.
- Step 1. Gently slide the rear panel out of the extrusion.
- Step 1. Make sure that adequate support and ESD safeguards are used when working on the assembly.
- Step 2. Set the jumper that matches the system's feedback voltage or current configuration. (See Table 4-1)

- Jumper Configuration Chart

JUMPER CONFIGURATION CHART	
CURRENT/VOLTAGE	JUMPER
0-20 mA/ 0-5V	W1 & W3
0-20 mA/ 0-10V	W1 & W4
4-20 mA/0-5V (Factory Default)	W2 & W3
4-20 mA/0-10V	W2 & W4

TABLE 1: ANALOG OUTPUT JUMPER SETTINGS

NOTE:

W2 & W3 are factory default settings.

Step 3. Reassembling Rear Panel

- Gently slide the rear panel back into the extrusion.
- Replace the four (4) pan head machine screws that fasten the rear panel to the extrusion.
- Connect the power cord.

Step 4. Front Panel Setup Procedures. (See Chapter 5, for instructions) To complete the Analog Option Card installation, you must complete the Setup procedures before operating the system.

Analog Card Adjustment

Slight adjustments may be necessary to insure that the display on your Programmable Logic Controller reads precisely with the display on your weight controller. Use the procedure below which corresponds to the input card in your PLC. (See Fig. 4-1)

- Make sure the Analog Option card is programmed correctly prior to performing any adjustments.

Step 1. Voltage

- If 0 volts represents other than empty put weight on your load cells equal to your 0 volt selection.
- Otherwise, with the hopper empty adjust R4 for the correct reading
- Put weight on your load cells equal to your 10 volt selection. Adjust R16 for the correct reading.

Step 2. Current

- Put weight on your load cells equal to your 4 ma selection, if 4 ma represents other than empty. Adjust R19 for the correct reading.
- Put weight on your load cells equal to your 20 ma selection. Adjust R5 for the correct reading.

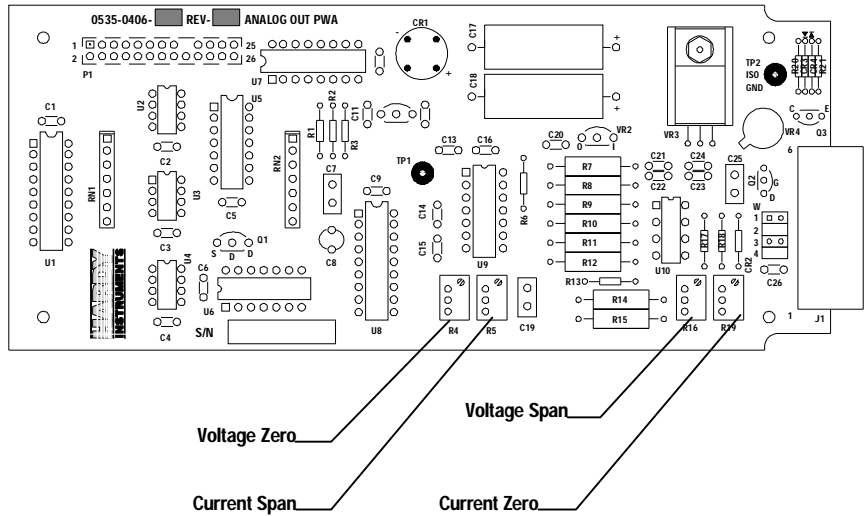

FIG. 4-1 ANALOG OUTPUT BOARD

Parallel BCD Board Print Configuration Procedures -B2, -B5, -B9

About the BCD Board Print Output Signal

Some receivers require either a positive (high) pulse or a negative (low) pulse when printing. Select the jumper that meets the receiver input signal requirements.

1. Jumper Location. (See Fig. 4-2)

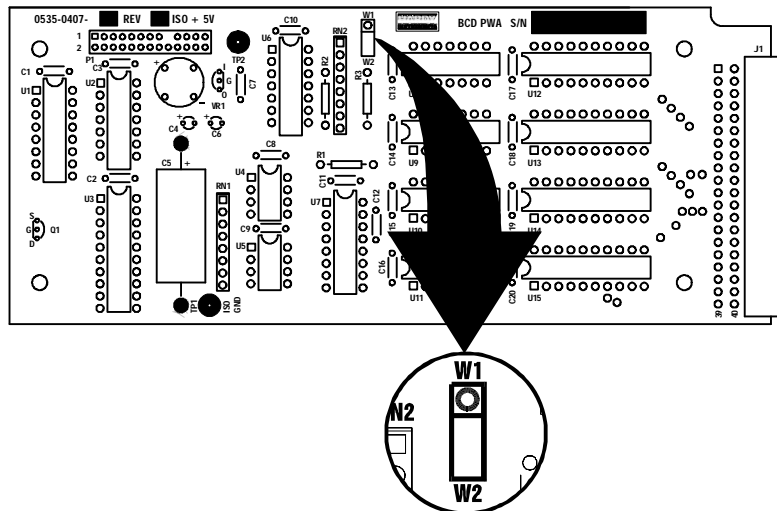

FIG. 4-2 BCD CARD JUMPER LOCATION PRINT/NO PRINT

1. Jumper Settings (See Fig. 4-3)

- Positive Pulse = W1
- Negative Pulse = W2 (Default)

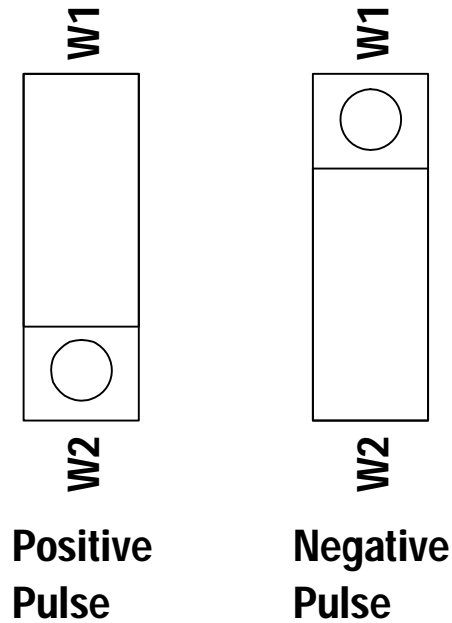

FIG. 4-3 BCD JUMPER SETTINGS/PRINT/NO PRINT

Auto Zero Tolerancing Configuration Procedures

About Auto Zero Tolerancing

When the Auto Zero Tolerance is enabled, any weight within the entered tolerance of zero and not in motion, will cause the display to automatically read zero.

Dip Switch Location
(See Fig. 4-4)

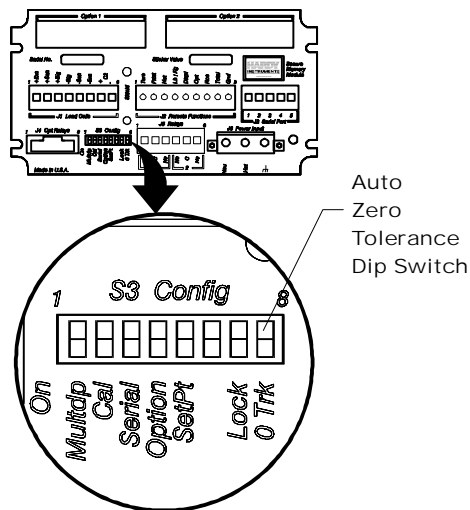

FIG. 4-4 AUTO ZERO DIP SWITCH SETTINGS

Dip Switch Setting

Step 1. To enable the Auto Zero Tolerancing, set dip switch #8 to ON.

Step 2. To disable the Auto Zero Tolerancing, set dip switch #8 to OFF.

Configuring Lock S3-7

1. When the switch is ON, the Tare, Mode, Zero, and lb/kg keys are locked out or not available.
2. When the switch is OFF, Tare, Mode, Zero, and lb/kg keys are available.

Configuring the Power Board Dip Switches S2 (See Fig. 4-5)

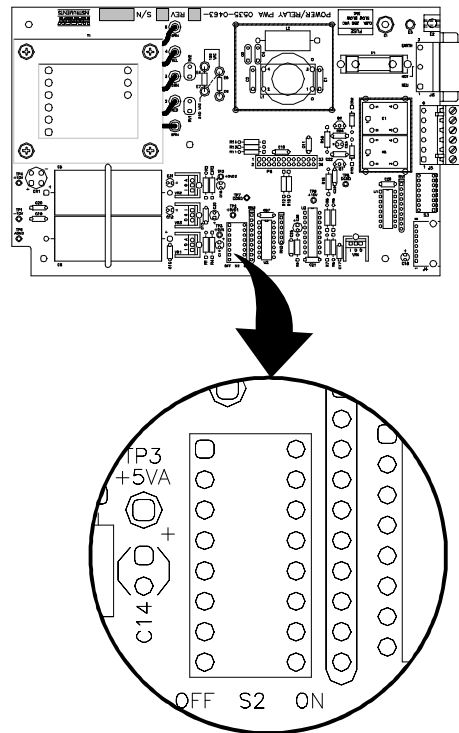

FIG. 4-5 POWER BOARD DIP SWITCH LOCATION

1. S2-3 - When the switch is ON, the instrument is in the NBS mode of operation. Resolution is limited to 1:10,000 counts. When the switch is OFF, the resolution is 1:985,000.
2. S2-4 - This switch must be toggled (position changed) to enter NBS calibration from the front panel CAL button.
3. S2-7 - is not used.
4. S2-8 - is used for resetting Calibration & Configuration to the Factory Defaults.

CHAPTER 5 - SETUP

SCOPE

All information contained in Chapter 5 pertains to firmware settings to prepare the controller for calibration and operation. Alternatives to these procedures explicit or implied, contained in this section are not recommended. It is very important that the user and service personnel be familiar with the procedures contained in this chapter, before going through the setup procedures.

Keypad Functions (See Fig. 5-1)

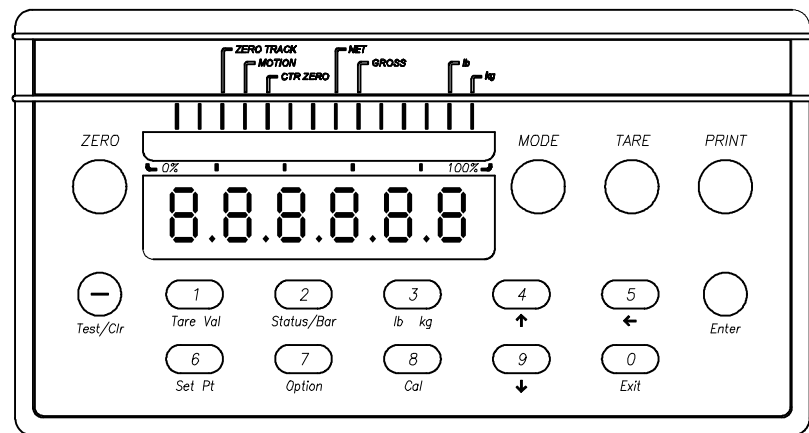

FIG. 5-1 FRONT PANEL

Zero

- Used in Gross mode to zero the display to within the tolerance level.
- This function can be used as many times as desired as long as the total does not exceed the value entered as the zero tolerance.
- The zero key is also used to exit a menu after entering number(s) without changing the original number. For example - when entering a Span value (18), the user decides that the original number (15) is OK. By pressing the Zero Key you can exit the menu without changing the original number (15), even though you have typed new numbers and they appear on the display.

Mode

- In standard controllers, the mode key toggles between gross and net weight.

Tare

- The Tare button captures the current Gross weight at the instant the Tare button is pressed and places it in the tare register setting the Tare Value. The tare value is the difference between the Net (e.g. Vessel weight) and Gross weight (e.g. vessel weight + material weight). You can also type in the Tare Value by using the 1/Tare Val key.
- The Tare function can also be actuated by activating the appropriate remote function pin. See Remote Function Configuration in Chapter 4.

- /Test/Clr**
- The Test/Clr function Initiates one of the selected tests
 - Self Test - "SLFTST" on the display.
 - This (—) key is used to enter a minus sign (-) for a negative number. This function can be used only when the display reads the number 0.
 - The clear "CLR" function is operable when the controller is a menu requiring a numeric input.
 - Use this key to clear the display before entering a new value.
- 1/Tare Val**
- This function displays the current Tare value stored in the Tare Register. (See paragraph 5.1.3)
 - This function allows the user, after pressing the "Clr" button, to enter a Tare Value using the numeric keys. To exit the Tare Val menu press the Zero button.
 - The key also enters the digit "1".
- 3/Lb Kg**
- Toggles between read pounds (Lb.) or kilograms (Kg.).
 - The key also enters the digit "3"
- 4/↑**
- This key moves forward through a menu, step by step and will wrap to the beginning of the menu.
 - The key also enters the digit "4"
 - Resumes the Self Test
- 5/←**
- Moves the decimal point position to the left when in Calibration Mode.
 - Selects user selectable formats in the optional BCD menus.
 - The key also enters the digit "5".
- 8/Cal**
- 1.This key opens the Calibration set up menu.
 - 2.The key also enters the digit "8".
- 9/↓**
- This key moves backward through a menu, step by step and will wrap to the beginning of the menu.
 - Selects user selectable formats in the Serial and optional BCD menus.
 - Pauses the Self-Tests.
 - The key also enters the digit "9".
- Exit**
- This key Exits a menu/sub-menu back to the normal operating mode when text is on the screen

NOTE:

The zero key is used to exit a menu when numbers are entered (See Paragraph 5.1.1).

- The key also enters the digit "0".

Enter

- When changing numerical values in a sub-menu, this key accepts or rejects the value.
- When a value is accepted a "GOOD" message will appear on the display and step forward to the next item on the menu.
- When a value is rejected an "ERR" message will appear on the display, and will display the entered value allowing the user to change the value. For a list of error messages see Chapter 7, Troubleshooting.

BCD Menu Setup Procedures**About BCD Communication (See Chapter 4 for Configuration Procedures)**

The BCD option board provides parallel output of a sensed gross, net, or tare weight. The BCD option is setup by first entering the Option Menu and selecting the FORMAT menu. The menu display shows a combination of **GNTDP** (G = gross, n = net, T = tare, D = display, P = print).

- The weight select mode tells the output device which type of data is present.
- The user selects which type of data is desired by toggling "GNT" under the Option/BCD sub-menu.
- If all three types of data are requested, then all three will appear on the output one after the other, 10 milliseconds apart.
- If "D" is selected, the output will follow the mode being displayed.

Setup Procedures

Step 1. Press the 7/Option key. This gives the user access to the Setup Sub-Menu, option displays.

NOTE:

The display may show an option other than "BCD", depending upon which options were installed. The HI 2110WI will show the first available option, in our example, BCD 2110WI. There is only one option slot.

Step 2. Press the up or down arrow until the sub-menu **BCD P1** appears.

Step 3. Press the Enter Button, the **FORMAT** sub menu appears.

Step 4. Press the Enter Button. A series of letters (**GNTDP**) and spaces appear. For example: **G N _ _ D P**. Note that in our example the "T" is not displayed and that there are 6 spaces total. The sixth value is used in other communication protocols.

Step 5. Print Output Options

- If you want to print mode value(s) selected, such as **G** (Gross weight), **N** (Net weight) or **T** (Tare) on demand, select **P**.

1. Press the up or down arrow $\uparrow\downarrow$ until the letter "P" appears.

2. Now when the Print button is pressed it will output the Gross, Net, or Tare weights, whichever one is selected.
3. If you select all three, "GNT", it will output all three in sequential order.

NOTE:

If your input device cannot handle rapid input of data, do not select more than one mode.

4. If you don't want this function, press the up or down arrow $\uparrow\downarrow$ until a space "_" appears.
- If you want to output what appears on the display, select "G".
 1. Press the left arrow one time \leftarrow to select "G" (BCD).
 2. Press the up or down arrow $\uparrow\downarrow$ until the "G" appears.
 3. Now whatever mode appears on the display it is output.
 4. If you do not want output, press the up or down arrow until a space appears "_".

Output Mode Options

Tare Mode

- Step 1. Press the left arrow \leftarrow two times to select "T".
- Step 2. Press the up or down arrow $\uparrow\downarrow$ until the "T" appears.
- Step 3. Now when the Output is triggered by the BCD Controller, the Tare Weight is sent.
- Step 4. If you do not want to select the Tare mode, press the up or down arrow $\uparrow\downarrow$ until a space appears "_".

Net Mode

- Step 1. Press the left arrow \leftarrow one time to select "N".
- Step 2. Press the up or down arrow $\uparrow\downarrow$ until the "N" appears.
- Step 3. Now when the BCD Controller triggers the output, the Net Weight is sent.
- Step 4. If you do not want to select Net mode, press the up or down arrow $\uparrow\downarrow$ until a space appears "_".

Gross Mode

- Step 1. Press the left arrow \leftarrow one time to select "G".
- Step 2. Press the up or down arrow $\uparrow\downarrow$ until the "G" appears.
- Step 3. Now when the BCD Controller triggers the output, the Gross Weight is sent.
- Step 4. If you do not want to select Gross mode, press the up or down arrow $\uparrow\downarrow$ until a space appears "_".

- Press the Exit button to return to the BCD Menu
- Press the Exit button to return to the Setup Menu.
- Press the Exit button to return to the Main Menu

Analog Output Setup Procedures (Option)

About Analog Output (See Chapter 4 for Configuration Procedures)

The analog output option allows the user not only to output gross, net as 0-5V, 0-10V, 0-20 mA or 4-20 mA (or the reverse of these via the front panel), but makes it possible to span these ranges over a portion of the weight data. A full analog output is obtained over the range desired. Resolution of the analog out is 16,000 counts, or the number of display counts available in the range selected, whichever is less. All of this is accomplished via the front panel or the serial port. Two analog option boards may be installed in each unit.

Analog Output Menu Setup Procedures

- Step 1. Press the 7/Option button.
- Step 2. Press the up arrow ↑ until Analog Output 1 **ANAOUT1** is displayed.
- Step 3. Press the Enter button. **ANLO** appears.
- Step 4. Press Enter button.
- Step 5. Press -/Test/Clr button to clear the entry.
- Step 6. Use the numerical keypad to enter the value desired. (Enter - for loss-in-weight systems.)
- Step 7. The value displayed will equal 4 milliamps, 0 milliamps, or 0 volts, depending on which output and configuration is used.
- Step 8. Press the Enter button. A **GOOD** will momentarily appear and **AN HI** appears.
- Step 9. Press the Enter button.
- Step 10. Press -/Test/Clr button to clear the entry.
- Step 11. Use the numerical key pad to enter the numerical value desired. (Enter (-) for loss-in-weight systems.)
- Step 12. The value displayed will equal 20 milliamps, 10 volts, or 5 volts, depending on which output and configuration is used.
- Step 13. Set mode by pressing **MODE** button until cursor is flashing under desired option. Select from total, gross or net. The default is gross.
- Step 14. Press the Enter button. **AN - LO** re-appears.
- Step 15. Press the Exit button. **ANAOUT** re-appears.
- Step 16. Press Exit button again to return to the weight display.

NOTE:

Display may show an option other than "ANAOUT", depending upon the option boards installed.

NOTE:

Previously set numerical value will be displayed. "0" is the default.

NOTE:

Display momentarily flashes good if value is a valid entry.

Set Up for Profibus Interface Card Option - B12

See the Profibus Interface Option, Card Operation and Installation Manual Prt. #0596-0231-01 for complete instructions.

Allen-Bradley Remote I/O Option -B8

See the Allen-Bradley Remote I/O Installation and Operation Manual Prt. # 0596-0173 for complete instructions.

CHAPTER 6 - CALIBRATION

SCOPE

Chapter 6 pertains to the calibration procedures for the HI 2110WI weight controller. Alternatives to any procedures implied or explicitly contained in this chapter are not recommended. In order for the weight controller to work properly, it must be calibrated prior to operation. All calibration should be done in the Gross mode. It is recommended that the instrument be re-calibrated periodically or when not in use for extended periods of time. Be sure to follow all the procedures completely to insure that the weights read by the controller are accurate. It is very important that the user and service personnel be familiar with the procedures contained in this chapter, before installing or operating the HI 2110WI weight controller.

Pre-Calibration Procedures

Mechanical Check Procedures

Step 1. Check to determine if the load cells have been installed properly.

- Refer to your load cell I&M manual for proper installation instructions.
- On some single and double ended shear beam load cells there is an arrow () that indicates the direction of the applied load. If the arrow is pointing in the wrong direction, change the position of the load cell so that it is mounted in the direction of the applied load.

Step 2. Check for Binding on the Load Cell or other parts of the system.

CAUTION

BINDING ON A SCALE/VESSEL OR LOAD CELL DOES NOT ALLOW THE LOAD CELL FREE VERTICAL MOVEMENT AND MAY PREVENT THE INSTRUMENT FROM RETURNING TO THE ORIGINAL ZERO REFERENCE POINT.

- A load cell must be mounted in such a way that 100% of the load (Vessel w/Contents) is vertically passed through a load cell. (See Fig. 6-1)
- Check to see that nothing is binding the load cell. This means that nothing is draped across the scale/vessel or the load cell, such as a hose, electrical cord, tubes, or other objects.
- Check to see that nothing is coming in contact with the scale/vessel other than service wires and piping that have been properly mounted with flexible connectors.

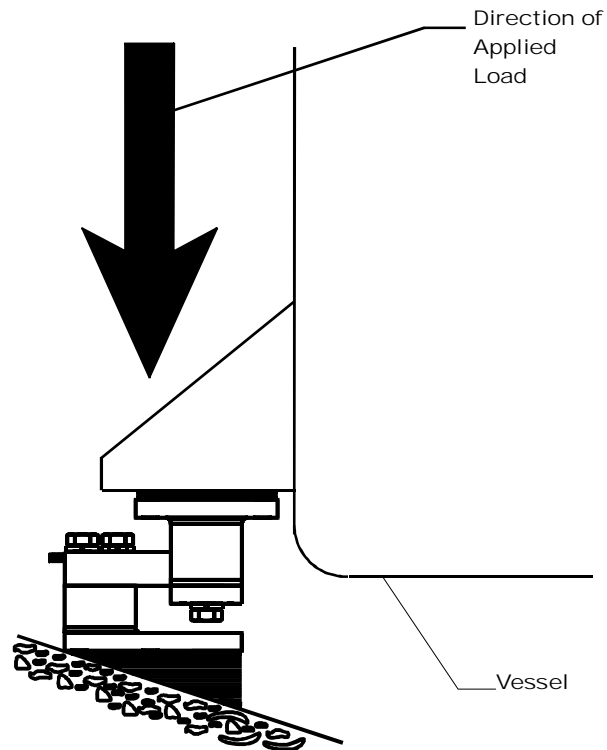

FIG. 6-1 PROPERLY INSTALLED LOAD CELL W/NO BINDING

Electrical Check Procedures

Step 1. Check to see that there is power to the controller.

- If there is power to the controller The front panel display should be lit.
- If the display appears with a value the unit is ready for calibration.

Step 2. Typical Load Cell/Point Input/Output Measurements (EXC & SIG Outputs)

- The HI 2110WI is designed to supply 5 VDC excitation to as many as four 350 ohm load cells/points.
- The expected output from each load cell/point depends on the mV/V rating of the load cell/point and weight.
- For example, a 2 mV/V load cell/point will respond with a maximum of 10 mVDC at full weight capacity of the system which includes the weight of the vessel and the weight of the product as measured by the load cell/point.
- If the load cell/point weight capacity is rated at 1000 pounds, the load cell/point output will be 10 mVdc at 1000 pounds, 7.5 mVdc at 750 pounds, 5 mVdc at 500 pounds and so on.
- A zero reference point will vary from system to system depending on the "Dead Load" of the vessel. "Dead

Load" is the weight of the vessel and appurtenances only, with no product loaded. In our example we will assume the dead load to be 500 lbs. (See Fig. 6-2)

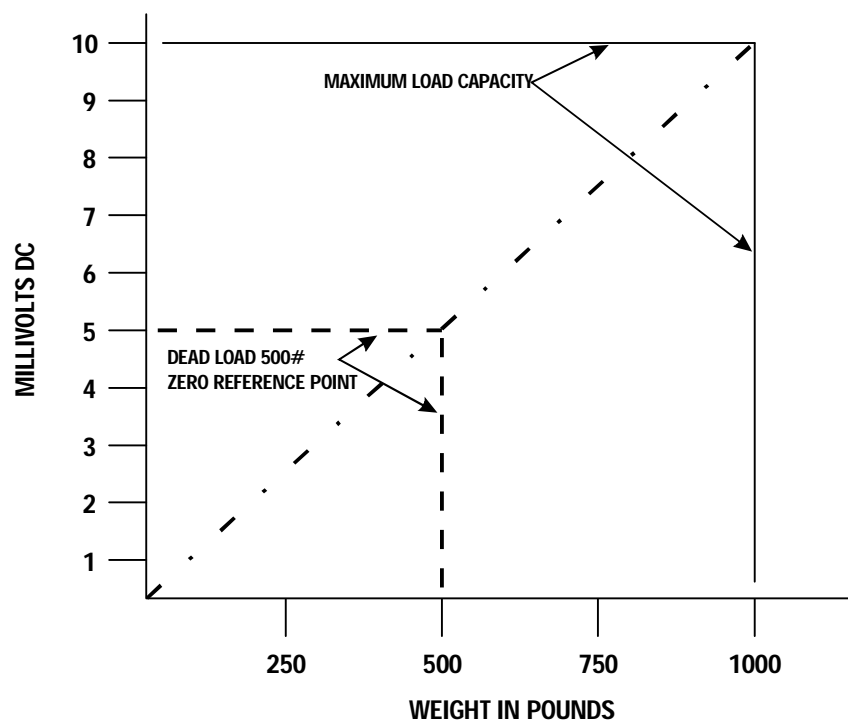

FIG. 6-2 MILLIVOLTS/WEIGHT SCALE

- Based on the example, the operating range for this scale is 5-10 mVdc with a 500 pound weight range. Understand that after zeroing the instrument, the 0 reading on the instrument refers to the zero reference point and not absolute 0 mVdc or absolute 0 weight.

NOTE:

Load cell/point measurements are checked with a digital volt meter at the summing junction box or the J1 connector on the rear panel of the HI 2110WI.

- Allow the controller to warm up for about 15 minutes before doing the calibration procedures.

Fourteen Segment Display

The display is a six-digit, fourteen segment display with selectable decimal placement. The display can show positive values up to 999999 and negative values down to -99999. The LED display shows operational status messages as well as actual numeric values. (See Figs. 6-3 & 6-4)

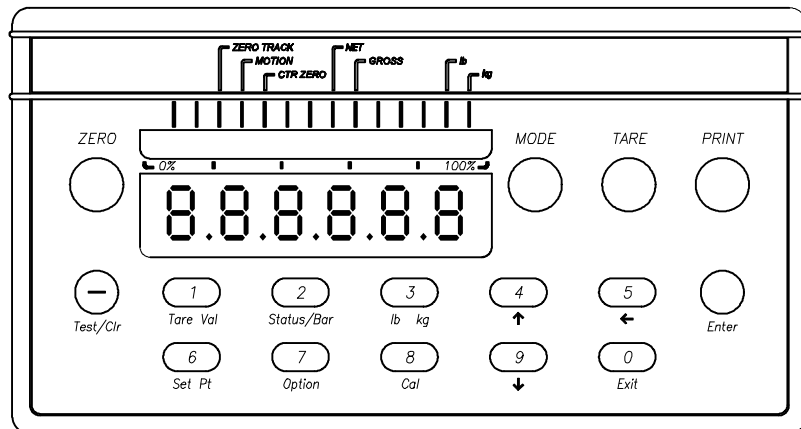

FIG. 6-3 FRONT PANEL DISPLAY WITH NUMBERS

Status Indicator

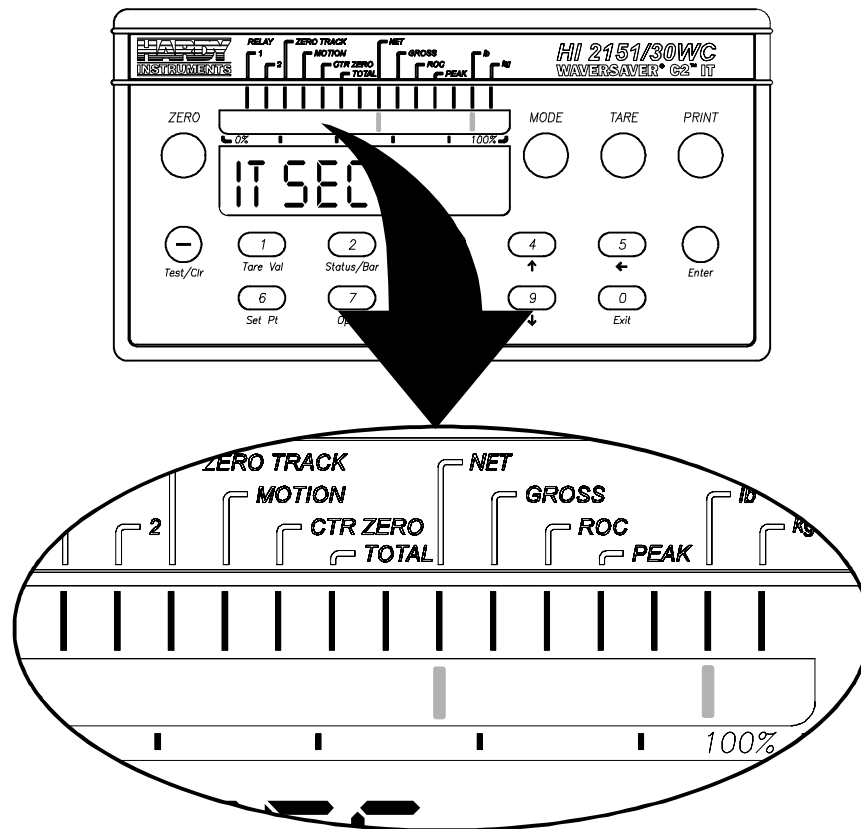

FIG. 6-4 FRONT PANEL STATUS LEDS DISPLAYED

DISPLAY

MEANING

CTR ZERO Indicates when the sensed weight is within 1/4 of a display grad of calibrated zero.

MOTION Indicates when the variation in consecutive weight

readings exceeds the calibrated motion tolerance.

ZERO TRACK Indicates when the zero track function is activated. Zero track is toggled on or off by the 0 Trk dipswitch (S3) on the rear panel.

GROSS/NET/ Indicates the mode of the measured value on the display. All calibration should be done in Gross mode.

Lb/Kg Indicates U.S. or metric unit-of-measure of the weight parameter on the display.

Load Check

- Step 1. Place a load (weight) on the scale or vessel.
- Step 2. Check to see if the weight reading changes on the display in the proper direction.
 - e.g. if the display reads 100 pounds and a 20 pound load is placed on the vessel or scale, the display should read 120 or some value over 100.
 - If the display reads 80 pounds and a 20 pound load is placed on the vessel or scaled, the reading is going in the wrong direction and indicates some problem with the system. (See the Chapter 8, Troubleshooting for corrective action.)
 - If the display is reading improperly or shows no change there is something wrong either with the setup or configuration.
- Step 3. If the display changes in the proper direction, remove the weight and proceed to calibrate the controller.

Calibration Setup Procedures

The Calibration Menu

NOTE: *When calibrating the instrument for the first time, go from one sub-menu to the next in sequence. If you want to change one of the sub-menus, continue to press the Up Arrow button until you reach the sub-menu you want to change.*

NOTE: *After entering a value in each sub-menu the display will flash a GOOD if the value is accepted. If the value is not accepted the display will flash an ERR # statement.*

- Step 1. Make sure the controller is in Gross Mode.
- Step 2. Press the Cal button. Security Code (SEC CD) is displayed.
- Step 3. Press the Enter button. A flashing zero (0) appears.
- Step 4. Enter the security code number (5321).
- Step 5. Press Enter. The word UNIT appears. Note the three leds (Zero Track, Motion, and CTR Zero) start to flash on the left side of the status display.

Setting the Unit of Measure (UNIT)

- Step 1. Press the Enter button. LB appears.
- Step 2. To select pounds (LB) press the enter button.
- Step 3. To select kilograms, press either the up or down arrow button until GR is displayed. Press the enter button.
- Step 4. The unit of measure is selected and will be the basis for all set points.
- Step 5. "DECPNT" appears on the display.

NOTE:

The displayed unit of measure can be changed during normal operation. However, all internal calculations use the unit of measure selected during calibration.

Setting the Standard Decimal Point (DECPNT)

- Step 1. Press the Enter button. Six number eights (88888.8) are displayed.
- Step 2. To select the decimal point location, push the left arrow (←) until the decimal point is in the correct position. The decimal point will wrap from left to right.

NOTE:

There is no right arrow (→).

- Step 3. Press the Enter button to accept the decimal location.

Setting the Motion Tolerance Value (MOTION)

- Step 1. The motion tolerance is the tolerance value used to determine if the scale is in motion.
- Step 2. The controller displays the MOTION LED whenever a change in the displayed (averaged) reading is outside the value entered.
- Step 3. Default value is 3 units of measure.
- Step 4. Press the -/Test/Clr button to clear the current value.
- Step 5. Use the numeric keys to type in the new tolerance value.
- Step 6. Press the Enter button, the Graduation Size GRAD appears on the display.

Setting the Graduation Size (GRAD)

- Step 1. The graduation size is the minimum increment computed and displayed by the instrument.
- Step 2. Press the Enter button. The graduation size 20 appears on the display with the zero (0) flashing.
- Step 3. There are 9 acceptable graduation sizes to choose from:

1	50
2	100
5	200
10	500
20	

- Step 4. To select one of the sizes, use the up arrow or down arrow keys to scroll through the selections.
- Step 5. The graduation size is recalculated each time the instrument is calibrated for span.
- Step 6. Press Enter to accept the selection. The Zero Tolerance (ZTOL) sub-menu appears on the display.

Setting the Zero Tolerance (0 TOL)

- Step 1. This value is the zero tracking window.
- Step 2. The default zero tolerance is 10 units of measure (10 is displayed). The maximum Zero Tolerance number that can be entered is 32766.
- Step 3. Press the Enter button. The default display will appear (10) or the previous set value (10).
- Step 4. Press the -/Test/Clr button to clear the current value
- Step 5. Use the numeric keys to enter the new value.
- Step 6. Press the Enter button to accept the new value. Zero Tolerance sub-menu (0 TOL) appears on the display.

Setting The Auto Zero Tolerance (A0 TOT)

- Step 1. When the Auto Zero Tolerance (A0 TOT) is enabled, (Set Dip Switch #8, See Chapter 4, Section 4.5) any weight within the entered tolerance of zero and not in motion, will cause the display to automatically read zero.
- Step 2. The default auto zero tolerance is 10 units of measure. The maximum Auto Zero Tolerance number that can be entered is 32766.
- Step 3. Press the Enter button. The default display will appear (10) or the previous set value.
- Step 4. Press the -/Test/Clr button to clear the current value
- Step 5. Use the numeric keys to enter the new value.
- Step 6. Press the Enter button to accept the new value.
- Step 7. If the value does not exceed the maximum zero tolerance value or is not a negative value, the screen will accept the new value.
- Step 8. If the value exceeds the maximum zero tolerance value or is a negative number, an ERR 15 is displayed. You need to change the value to meet the requirements in step "7". Go to step 4 and repeat steps 4, 5 & 6 to enter new values until the value meets the requirements in Step 7.
- Step 9. Press the Enter button to accept the new value. "AVERAGE" sub-menu appears.

NOTE:

Weight can accumulate up to the value entered for the Auto Zero Tolerance and the instrument will automatically display a 0.

Setting the Number of Readings Averaged (AVRAGE)

- Step 1. This sets the number of weight readings which will be used to compute the displayed weight.
- Step 2. The average is a sliding average so that a new average is available for display at every reading.
- Step 3. The default number of readings per average is 100.
- Step 4. Press the Enter button.
- Step 5. Use the numeric keys to enter the new value. The value range is 1 to 200.
- Step 6. If you enter a number greater than 200 or a negative number, the ERR 3 statement will appear. You need to enter a number between 1 and 200. Press the -/Test/Clr button. Enter a new number.

Setting the Scale Capacity (SC CAP)

Step 7. Press the Enter button. The Scale Capacity (SC CAP) sub-menu appears.

Step 1. This value is the nominal operating capacity of the scale.
Step 2. The value you set should be the smaller value between the capacity of the vessel (volume in gallons or Liters converted to weight in Lbs or Kgs) and the combined weight capacity of the load cells (Lbs or Kgs). For example:

A vessel's capacity in volume is 2,000 gallons, in this case water. (One gallon of water weighs approximately 8.54 lbs.) The weight will be 17,080 lbs. The combined live load capacity of the load cells is 20,000 lbs. Select the lesser of the two values which in our example is 17,080 lbs. Enter 17,080.

Step 3. Press the Enter button. The WAVERSAVER® (WVRSVR) sub-menu appears.

WAVERSAVER® (WVRSVR)

Step 1. Press the Enter button.
Step 2. A value appears. The Default setting is 4.
Step 3. There are 5 selectable levels.

- 1 provides the least vibration immunity with the fastest response time.
- 5 provides the most vibration immunity with the slowest response time.

Step 4. Press the up arrow to select the setting (1-5).
Step 5. Press Enter to accept the value. The Calibration (CAL) sub-menu appears.

This ends the Calibration Setup Process.

Calibration Procedures

Step 1. Press the Enter button. The Hard Calibration HD CAL Sub-Menu appears.
Step 2. Use the Up or Down arrows ↑↓ to select one of the Calibration procedures:

C2™ Calibration (C2 CAL)
Hard Calibration (HD CAL)

NOTE:

Select one calibration process only. C2 and Hard Calibration are used most often. C2 Calibration is only possible with Hardy Instruments Load Cells/Sensors or Points.

C2™ Second Generation Calibration Procedures

Step 1. From the CAL menu, press the down arrow button. The C2 CAL sub-menu appears.
Step 2. Press the Enter button. The Load Cell Count LC CNT sub-menu appears.
Step 3. Checking the Load Cell Count

- Check to see that the load cells detected by C2 calibration are equal to the actual number of load cells installed in the system.
- If the load cells detected do not match the load cells installed in the system do the following:
 - Cycle Power and recheck.
 - Press the Enter button.
 - Press the Exit button.
 - Press the -/Tst/Clr button. The Self Test (SLFTST) menu appears.
 - Press the Enter button to perform the Self Test. The Self Test will give the serial numbers of the load cells that are found by the instrument. If one of the serial numbers is not found it means that a load cell is not communicating with the instrument. Verify that the load cell wires are properly connected. See the Load Cell certificates for color code information.

NOTE:

The controller can detect up to 4 C2 load point/cells on one vessel. The load points/cells are detected during power-up.

Setting the Reference Point (REF PT)

- Step 4. Press the Enter button. The Reference Point REF PT sub-menu appears.
- Step 1. Press the Enter button.
- Step 2. Press the -/Tst/Clr button to clear the current entry.
- Step 3. Use the numeric keys to enter the reference weight or use the default reference weight "0" by pressing the Enter button.

- Any known weight within the scale range can be used as the reference weight. The recommended and default value is zero (0).
- Make sure that there is no vibration on or around the scale/vessel or is as low as possible.
- Press the Enter button. The RETURN display appears.

Using the Return Button (RETURN)

- If you want to change any setting(s) in the C2 Calibration procedures, push the up arrow which takes you back to the load cell count LC CNT sub-menu. Press the up arrow until the sub-menu you want to change appears then press the Enter button. Follow the procedures above for the menu.
- If you want to accept the C2 Calibration parameters press the Enter button. The End Calibration END CAL message is displayed.
- Press the Enter button again. This seals all calibration settings and exits the C2 Calibration Menu.
- The instrument returns to the normal weight display.

NOTE: *If the Enter button is not pushed after End Cal appears, three leds will flash indicating that the settings are not sealed in memory.*

End of C2 Calibration

NOTE: To correct mistakes during calibration, or to return to a previous calibration parameter, press the down arrow to bypass parameters, press the up arrow ↑.

C2 Calibration Self Test Procedures

- Step 1. At the Main Menu Press the -/Test/Clr button.
- Step 2. Get ready to write down all the self test parameters (which include the C2 calibration settings) on the Self-Test, Calibration Results form. (See Appendix A: HI Document # 0570-0016-01 for single controllers or 0575-0016-02 for multiple controllers) Please photocopy as many copies of the form(s) as you need.
- Step 3. Press the -/Test/Clr button. The Self Test **SLFTST** display appears.
- Step 4. Press the Enter button. The Self Test menu appears.
 - Press the down arrow button to pause the test.
 - Write down the results of each test in the Self Test Program Results Form - Calibration Results column.
 - Write down the value(s) displayed after each test name. For example "Slot 1" appears on the display. Press the up arrow one time and the value for Slot 1 appears, in our example NONE. Write none down in the results column for Slot 1 on the Self Test - Calibration form.
 - There are two tests which are Pass/Fail. The Check Sum and the RAM test. If the controller fails either one of these tests contact your local representative or Customer Support Center.
- Step 5. Press the Exit button.
- Step 6. Press the Exit to the Weigh Mode.

Hard Calibration Procedures (HDCAL)

NOTE: *Hard Calibration is the traditional method of calibration that uses test weights. We recommend that the test weights total 80 to 100% of the scale weight.*

Selecting the Hard Calibration Sub-Menu

- Step 1. From the Weight Display, Press the 8/Cal button. The Security Code (**SEC []**) displays.
- Step 2. Press the Enter Button. A flashing zero (0) appears.
- Step 3. Enter the security code number (5321), then press the Enter button. The Unit of Measure UNIT Sub-menu appears.
- Step 4. Press the up or down arrows ↑↓ until the CALSub-Menu appears.

- Setting the Zero Calibration Value
- Step 5. Press the Enter button. The Hard Calibration HD CAL Sub-Menu appears.
 - Step 6. Hard Calibration requires a zero point and the physical placement of test weights on the scale.
 - Step 7. Press the Enter button. The ZERO sub-menu appears.

- Step 1. Remove all weight "live load" from the scale.
- Step 2. Press the Enter button. A dash "--" appears.
- Step 3. Press the -/Test/Clr button. A "0" appears.
- Step 4. Wait 12 seconds.
- Step 5. Press the Enter button.
- Step 6. Either a 5000 or ERR# appears.
- Step 7. If an ERR number appears go to Chapter 8, Troubleshooting for more information.
- Step 8. If a 5000 appears the Span (SPAN) display appears.

- Setting the Span Calibration Value
- Step 1. Place a certified test weight on the scale.
 - Step 2. Press the Enter button.
 - Step 3. Press the /Test/Clr button. The previous span value appears.
 - Step 4. Press the /Test/Clr button. A "0" appears.
 - Step 5. Use the numeric keys to enter the value of the test weight. (If a 50 lb.weight is used, enter 50).

NOTE: *Ideally the test weight used for the dead load should be the typical weight that will be measured in the application.*

- Step 6. Wait 12 seconds.
- Step 7. Press the Enter button to set the span. The Linear Correction (LINCOR) Sub-Menu appears.

Setting the Linear Correction Value

NOTE: *Linear correction is normally not required. To bypass linear correction press the Enter button two times.*

- Step 1. Test for non-linearity by placing a test weight on the scale.
- Step 2. If your scale range is 0-100 pounds, add a 10 pound weight to the scale.
- Step 3. Write down the actual weight and the weight on the display. If the actual weight is 10 pounds and the display reads 10.2 pounds write both values down.
- Step 4. Add another 10 pound weight.
- Step 5. Write down the actual weight (20 lbs) and the weight on the display 20.4 pounds.
- Step 6. Continue this process until the weights added equal 100 pounds.
- Step 7. Remove the weights until you reach the weight with the largest difference between actual and displayed weight. (e.g. 30

pounds actual 30.8 displayed, discrepancy .8 pounds). This is the weight used to set the linear correction value.

Step 8. Use the numeric keys and enter the test weight value that displayed the largest discrepancy, in this example 30 pounds. Do not add the displayed weight value 30.8.

Step 9. Press the Enter button to set the value. The RETURN display appears.

The Return (RETURN) Display

Step 1. The RETURN Display allows the user to change any setting(s) entered in the Hard Calibration Sub-Menu.

Step 2. Push the up arrow which takes you back to the Zero Sub-Menu.

Step 3. Press the up arrow until you reach the sub-menu you want to change and press enter.

Step 4. Follow the procedures for each Sub-Menu you want to change.

Step 5. If you want to accept the Hard Calibration parameters entered, press the Enter button. The End Calibration END CAL message is displayed.

Step 6. Press the Enter button. This seals all calibration settings and exits the Hard Calibration Menu.

Checking for Mechanical Problems

Step 1. Place a test weight on the scale.

Step 2. Check the displayed weight value.

Step 3. Remove the test weight from the scale.

- If the displayed value is zero (0) the hard calibration is complete.
- If some value other than zero (0) is displayed, check for mechanical problems, most likely binding in the system. (See Chapter 8, flow chart h for details) Correct the problems and perform the Hard Calibration Process again.

NOTE:

To correct mistakes during calibration, or to return to a previous calibration parameter, press the down arrow to bypass parameters, press the up arrow ↑.

Hard Calibration Self Test Procedures (Traditional Method Using Test Weights)

Step 1. Perform the Hard Calibration Self Test

- Press the -/Test/Clr button. The Self Test SELFTEST Sub-Menu appears.
- Write down all the Hard Calibration self test parameters on the Self-Test, Calibration Results form. (See Appendix A, HI Document # 0570-0016-01 for single controllers or 0575-0016-02 for multiple controllers) Please photocopy as many copies of the form(s) as you need.
- Press the down arrow button to pause the test.
- To review the test results, Slot 1 for example. Press the down arrow to pause the Self Test. Press the up arrow one time and the value for Slot 1 appears for example

“none”. Write "none" down in the results column for Slot 1 on the Self Test - Calibration form. The user can continue to push the up arrow to review more results, or let the controller resume the self test until the tests are completed.

- There is one test which is Pass/Fail. The RAM test. If the controller fails either one of these tests, contact your local representative or Customer Support Center.

Quick C2™ Calibration Procedures

About Quick C2 Calibration

The quick C2 calibration should be used when the controller has already been properly calibrated and when the system is determined to be slightly out of specification, for a scheduled periodic calibration.

- Step 1. The Quick C2 calibration procedures do not replace the regular C2 calibration procedures.
- Step 2. From the CAL menu press the Enter button. The **HC CAL** menu appears.
- Step 3. Press the down arrow. The C2 Calibration sub- menu **C2 CAL** appears.
- Step 4. Press the Enter button. The Load Cell Count **LC CNT** appears.
- Step 5. Press the up arrow. The Reference Point sub-menu appears.
- Step 6. Press the Enter button.
- Step 7. Enter the weight of the current "live load" that is on the scale.
- Step 8. Press the Enter button. The **RETURN** display appears.
- Step 9. Press the Enter button. The **END CAL** display appears
- Step 10. Press the Enter button to set the changes.

Quick Hard Calibration Procedures (Traditional Calibration using Test Weights)

- Step 1. The quick hard calibration should be used when the controller has already been properly calibrated and when the system is determined to be out of specification, or periodic scheduled calibration.
- Step 2. The procedures must be done in the Gross Mode.
- Step 3. The procedures calibrate the zero and span functions only.
- Step 4. From the CAL Sub-Menu, press the Enter button. The Hard Calibration Sub-Menu **HC CAL** display appears.
- Step 5. Press the Enter button. The Zero sub-menu **ZERO** appears.
- Step 6. Press the Enter button. A dash "- -" appears.
- Step 7. Remove all live load from the scale so that the load cell input is at its lowest reading.

- Press the **-/Tst/Clr** button. An "0" appears.

- Step 8. Wait 12 seconds.
- Step 9. Press the Enter button.

Step 10. Press the -/Tst/Clr button to clear any displayed value.

- Press the Enter button.

Step 11. The Zero is set and the Span sub-menu **SPAN** appears.

Step 12. Place a test weight (preferably a weight equal to 80% to 100% of the range of the scale) on the scale to bring the load cell input to full range.

Step 13. Wait 12 seconds.

Step 14. Press the Enter button. A dash " - - -" appears.

Step 15. Press the -/Tst/Clr button to clear any displayed value.

Step 16. Use the numeric keys to enter the test weight.

Step 17. Press the Enter button to set the span value. The **LINCOR** sub-menu appears.

Step 18. Remove the weight from the scale.

Step 19. Press the up arrow. The **RETURN** display appears.

Step 20. Press the Enter button. The **ENDCAL** display appears.

Step 21. Press the Enter button to exit the Calibration menu.

NOTE:

There is no quick Soft Calibration Process.

Procedures to Restore Calibration Parameters (Not Used for Systems that are Calibrated Using C2)

Before Clearing Memory

Step 1. If the parameters for the controller are on the Self Test - Calibration Form (Prt. # 0575-0016) enter the values from the form.

Step 2. If the user does not have the parameters from Self Test - Calibration Form handy, go through the Self Test again and write down the parameters.

CAUTION

IF CONTROLLER MEMORY IS CLEARED, ALL OPERATING SETTINGS ARE RETURNED TO THE ORIGINAL FACTORY DEFAULT PARAMETERS. ALL CALIBRATION, AND OPTION PARAMETERS SHOULD BE RECORDED BEFORE CLEARING MEMORY OR THE CONTROLLER WILL HAVE TO BE RE-CALIBRATED.

Clear Controller Memory

Step 1. First, Contact your Customer Support Department for instructions to clear controller memory.

Step 2. Re-enter the original Option parameters on the Self Test - Calibration form.

Step 3. Re-enter the Calibration parameters.

- From the **CAL** menu press the Enter button. The Hard Calibration Sub-Menu **HD CAL** appears.
- Press the Mode button. The Zero Count sub-menu **ZR CNT** appears.
- Press the Enter button.

- Enter the ZR CNT self test parameter from the Self Test - Calibration form.
- Press the Enter button. The Span Sub-Menu SPAN appears.
- Press the Enter button.
- Enter the SPAN self test parameter from the Self Test - Calibration form.
- Press the Enter button. The Full Scale Count FS CNT Sub-Menu appears.
- Press the Enter button.
- Enter the FS CNT self test parameter from the Self Test - Calibration form.
- Press the Enter button. The RETURN display appears.

Step 4. Press the Enter button to set the parameters, the END CAL display appears.

Step 5. Press the Enter button to save the updated parameters to the SMM and return to the weight display.

Restoring Calibration When Changing Decimal Points

Restoring Decimal Points

- Step 1. If you wrote down the parameters for this controller on the Self Test - Calibration Form (Prt. # 0575-0016) enter the values from the form.
- Step 2. If you didn't write down the parameters on the Self Test - Calibration Form, get the form and write them down.
- Step 3. Check all Option and Calibration entries for the correct decimal position.

NOTE:

You must complete procedures "c" before moving to procedure "d" to be sure that the decimal points in the correct position. If you don't check the decimal positions the calibration will be incorrect.

Step 4. From the CAL menu press the Enter button. The Hard Calibration Sub-Menu HD CAL appears.

Step 5. Press the Mode button. The Zero Count Sub-Menu ZR CNT appears.

Step 6. Press the Enter button. The current value is displayed.

Step 7. Press -/Test/Clr button and enter the correct ZR CNT or Press the Enter button to accept the current value. The Span Sub-Menu SPAN Sub-Menu appears.

Step 8. Press the Enter button. The current value is displayed.

Step 9. The new decimal point will be displayed in the SPAN Sub-Menu but it might be in the wrong place and displaying the wrong span value.

- Step 10. If the Span Value should be 2000.00 and the current display shows 200.00, add a zero (0) by pressing the 0 button. Now the value is correct.
- Step 11. If the Span Value should be 200.00 and the current display shows 2000.00, press -/Test/Clr button and enter 200.00.
- Step 12. Press the Enter button. The Full Scale Count Sub-Menu FS CNT appears.
- Step 13. Press the Enter button. The current value is displayed.
- Step 14. Press the -/Test/Clr button, enter the correct FSCNT then press the Enter button or press the Enter button to accept the current value.
- Step 15. The RETURN display appears.
- Step 16. Press the Enter button. The END CAL display appears.
- Step 17. Press the Enter button. The Secured Memory Module is updated and the system exits the Calibration Sub-Menu and returns to the weight display.

CHAPTER 7 - OPERATION

SCOPE

All information contained in Chapter 7 pertains to the operation of the HI 2110WI weight controller. We recommend that the process and procedures contained in this chapter, be followed to insure that the controller gives the user maximum quality performance. It is very important that the user be familiar with this chapter before operating the weight controller.

Description of Front Panel (See Fig. 7-1)

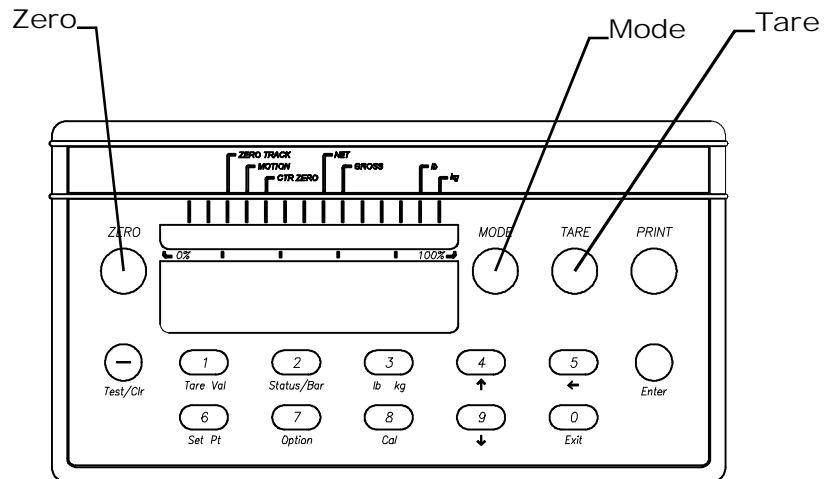

FIG. 7-1 FRONT PANEL, PROCESS WEIGHING FUNCTION BUTTONS

Process Weighing Function Buttons

ITEM	LABEL	BRIEF DESCRIPTION
ZERO	ZERO	Sets current count as new gross zero reference point. The ZERO button will only zero up to the zero tolerance value entered in the calibration menu. (See Chapter 6) The user can zero the instrument as many times as desired as long as the total does not exceed the value entered as the zero tolerance. Exits a numeric entry in a menu without changing the original value.
MODE	MODE	<u>Standard Mode</u> Selects Standard Net, Gross modes.
TARE	TARE	Captures current displayed gross weight and places value in the tare register. Sets display to zero in net mode.

Operator Displays

ITEM	LABEL	BRIEF DESCRIPTION
LEDs		Discrete LEDs display weight controller status
Display		Fourteen-segment LED display for displaying menus, operator inputs and selected weight displays.

Instrument Operation Overview

There is one main operating menu - Option. To enter this menu, press the proper button. Once in a particular menu, use the up and down arrow buttons to scroll through the choices of that menu. Some of the menus have sub-menus. To select an item for viewing and/or changing, press the Enter button when the menu item displays; the current value or status of the menu item is displayed.

To change values, use the numeric keypad, or press the Exit button if no changes are made. Use the -/Test/Clr button when a value is shown on the display to clear the display to all zeros. When clearing the display, the unit will always keep the decimal location intact by putting zeros to the right and one zero to the left of the decimal point. Some menu selections can be toggled using the ↑ and ↓ buttons. Pressing the arrow buttons will display all available selections for the menu item. Whether altering a value or not, when you are ready to stop viewing this parameter and go on to the next, press the Enter button to accept the value or press the exit button to keep the original value. This will save the parameter as shown on the display.

The instrument will also verify that the value entered is a logical choice. If a parameter has been entered correctly, a GOOD will briefly appear and the display advances to the next item in the menu. If a parameter has been entered incorrectly, an error ERR statement appears. A list of error statements are provided in Chapter 7 - Troubleshooting. After checking the error statement, correct the error.

To simply view a parameter value without changing the value, push the Enter button. If when changing a value you decide to retain the original value, press the ZERO button instead of the Enter button. This will save the original value and advance to the next parameter.

Option Menus and Option Parameters

Option menus are used to set parameters for the various option boards. All option parameters are automatically saved and updated in the Secure Memory Module. The following sections describe menu operation. (See Fig. 7-2)

NOTE:

Do not modify ANY Sub menus, while the serial interface or A-B RIO are attempting to modify information.

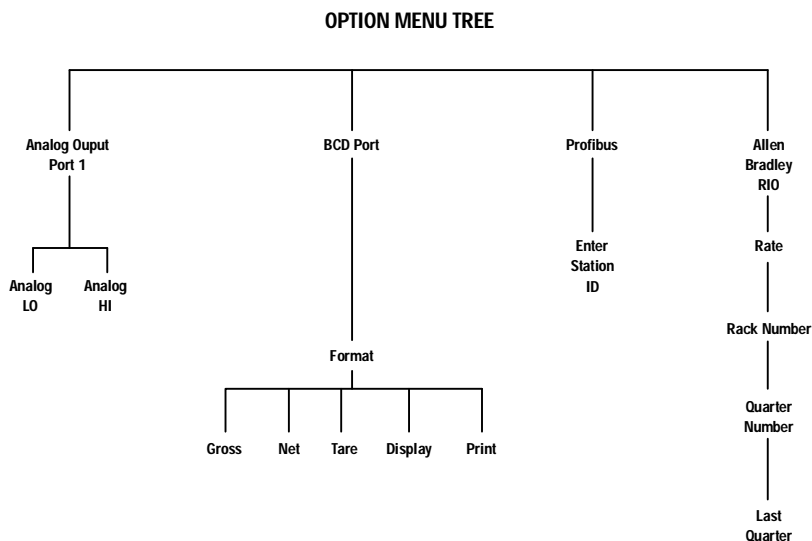

FIG. 7-2 OPTION MENU TREE

Option Boards

The option boards add capabilities beyond the standard HI 2110WI instrument. They are easily installed into the option board slot on the rear panel of the instrument.

General Information

NOTE:

If your options have already been installed at the factory, move on to Set points.

The options are implemented by installation of the appropriate optional circuit board onto the main analog/digital board in the instrument. (See Chapter 3 for installation instructions)

The following option boards are available for the HI 2110WI:

- Analog Output board (voltage and current outputs: Net, Gross,).
Prt. # 0551-0326, model HI 2110X-B1. (*If ordered)
- Parallel BCD board, tri-stated. With 6" cable P/N 0551-0327,
model HI 2110XX-B2. With 24" cable Prt. # 0509-0389-02,
model HI 2110XX-B9. With 60" cable Prt. # 0551-0330, model
HI 2110XX-B5.
- Allen-Bradley RIO. Prt. # 0551-0351, model HI 2110XX-B8.
- PROFIBUS Field Bus Interface. Prt. # 0535-0439, model HI
2110XX-B12.

Parallel BCD Communication

Operating Procedures

- The BCD option is setup by first entering the Option Menu and selecting the BCD menu. The menu display shows a combination of

GNTDP (G = gross, n = net, T = tare, D = display, P = print). (See Chapter 5, Section 5.5 for setup instructions)

- The user may select which data will be present at the output. If the "P" or print flag is selected, the data will only change at the output once the PRINT button is pressed or the remote functions print has been activated. Otherwise, the output will be continuous.
- The output can be triggered by any one of the following methods:

By pressing the PRINT button.

By connecting the remote functions print to the remote functions ground.

- The output can be tri-stated if the OUTPUT DISABLE is brought low. This is useful for multiple parallel outputs to be connected to the same device. Once this input is brought high, the latched data will be accessible again. The PRINT output is normally low and goes high for 25 milliseconds. If the opposite polarity (normally high, pulsed low) is desired, move jumper from W1 to W2.

BCD Print

- The weight select mode tells the output device which type of data is present.
- The user selects which type of data is desired by toggling "GNT" under the option BCD sub-menu.
- If all three types of data are requested, then all three will appear on the output one after the other, 10 milliseconds apart.
- If "d" is selected, the output will follow the mode being displayed.

Output Disable

- Data output is discontinued if the OUTPUT DISABLE, pin 22 on the PWA (pin 30 on the D-Subminiature connector), is low. The data pins will be tri-stated even though print pulses will be sent.

Allen-Bradley Remote I/O Option - B8

- See the Allen-Bradley Remote I/O Installation and Operation Manual (P/N 0596-0173) for complete Operating Instructions.

Profibus Interface Option -B12

- See the Profibus Installation and Operation Manual (Prt. # 0596-0231-01) for complete Operating Instructions.

CHAPTER 8 - TROUBLESHOOTING PROCEDURES

SCOPE

Chapter Eight consists of all the procedures for troubleshooting the electrical, mechanical and firmware elements of the HI 2110WI Weight Controller in the event of a malfunction. Included in Chapter Eight is a comprehensive flow chart to provide a road map for troubleshooting an entire weight control system, including load cells, weight controller and cabling.

Disassembly and Reassembly Notes and Cautions

- Always disconnect the power cord before disassembling.
- Make sure that any disassembly is done in a clean, well ventilated, properly controlled static environment.
- Always make sure that the assemblies and sub-assemblies are well supported and insulated when doing any repairs on the HI 2110WI Weight Controller.
- Place small fasteners, connectors and electrical parts in closed containers so as not to lose parts during reassembly.
- Read all the disassembly instructions before any disassembly begins. Be sure that you are familiar with the procedures. If any of the instructions for disassembly are unclear, contact your local Customer Support Center for additional information and assistance.
- Do not disconnect any electrical plug, connector or terminal unless an identification tag is present or one is attached. Always note where the connector or plug was attached to the electrical component or wiring harness.
- Always install complete hardware groups (Screws, Washers, Lock Washers, Spacers, Etc.) back to the original point of removal.
- Always replace broken or damaged modules or hardware immediately!
- Always check to be sure that no loose parts are sitting on printed circuit boards or electrical connectors or wires when disassembling or reassembling.
- Always protect printed circuit boards from electrostatic discharge (ESD). Always use approved ESD wrist straps and anti-static pads when working on the PROFIBUS Interface Card.
- Always perform a final inspection after completing any reassembly to be sure that all fasteners are tight, all connectors are secure and there are no loose parts on any of the printed circuit boards in the HI 2110WI.

- Always follow proper safety procedures when working on or around the HI 2110WI weight controller.

General Troubleshooting Flow Chart Index

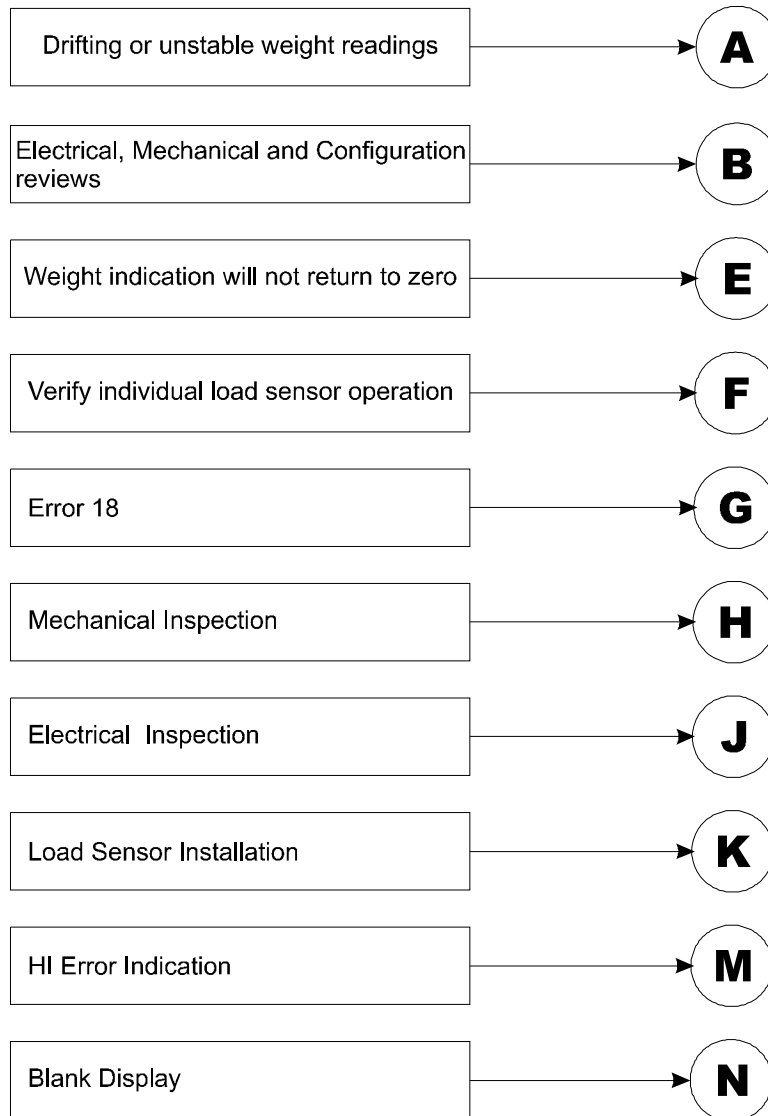

A- Guidelines for Instabilities on Formerly Operating Systems

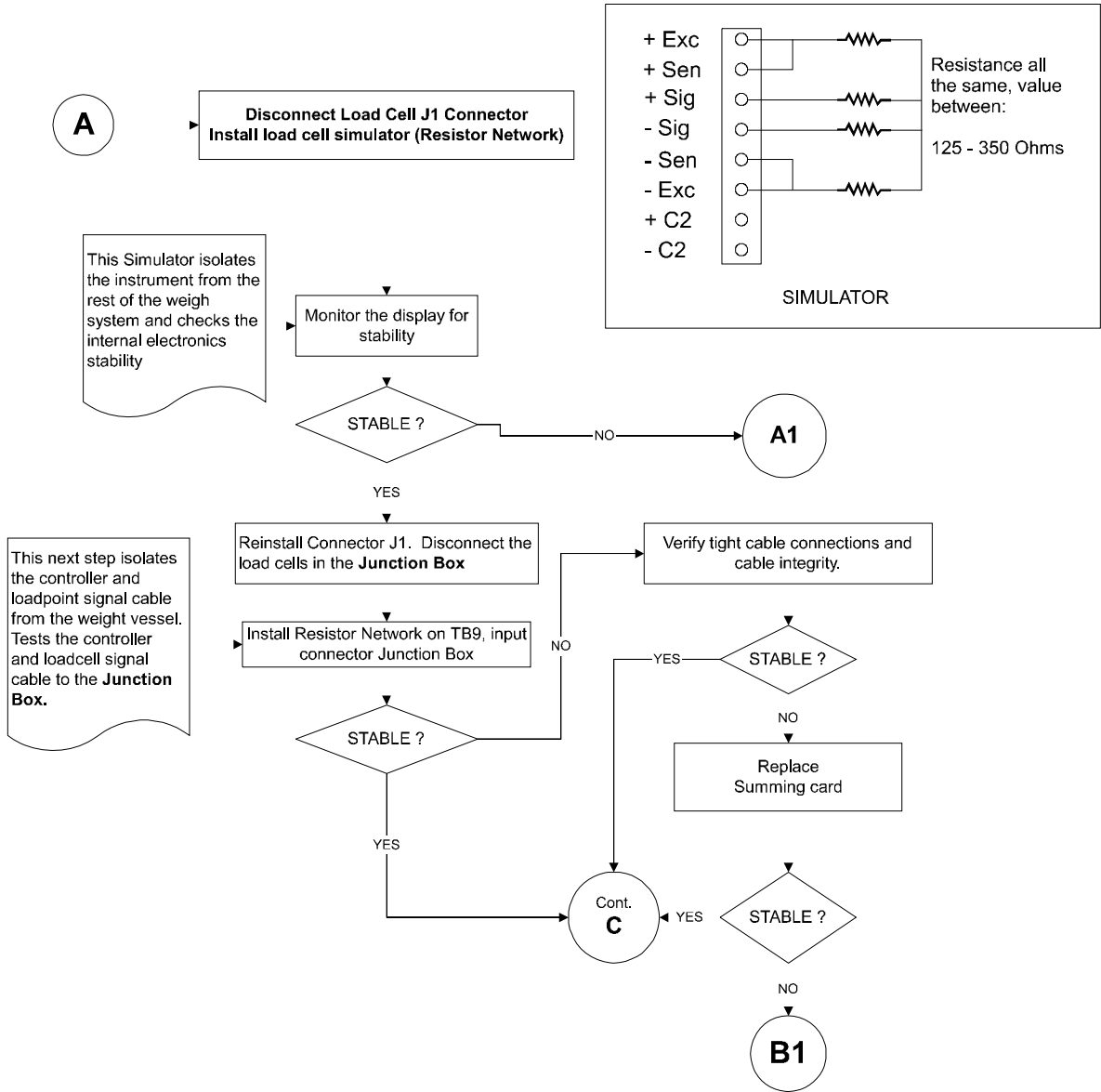

**A1- Guidelines for
Instabilities on Formerly
Operating Systems
(Cont'd)**

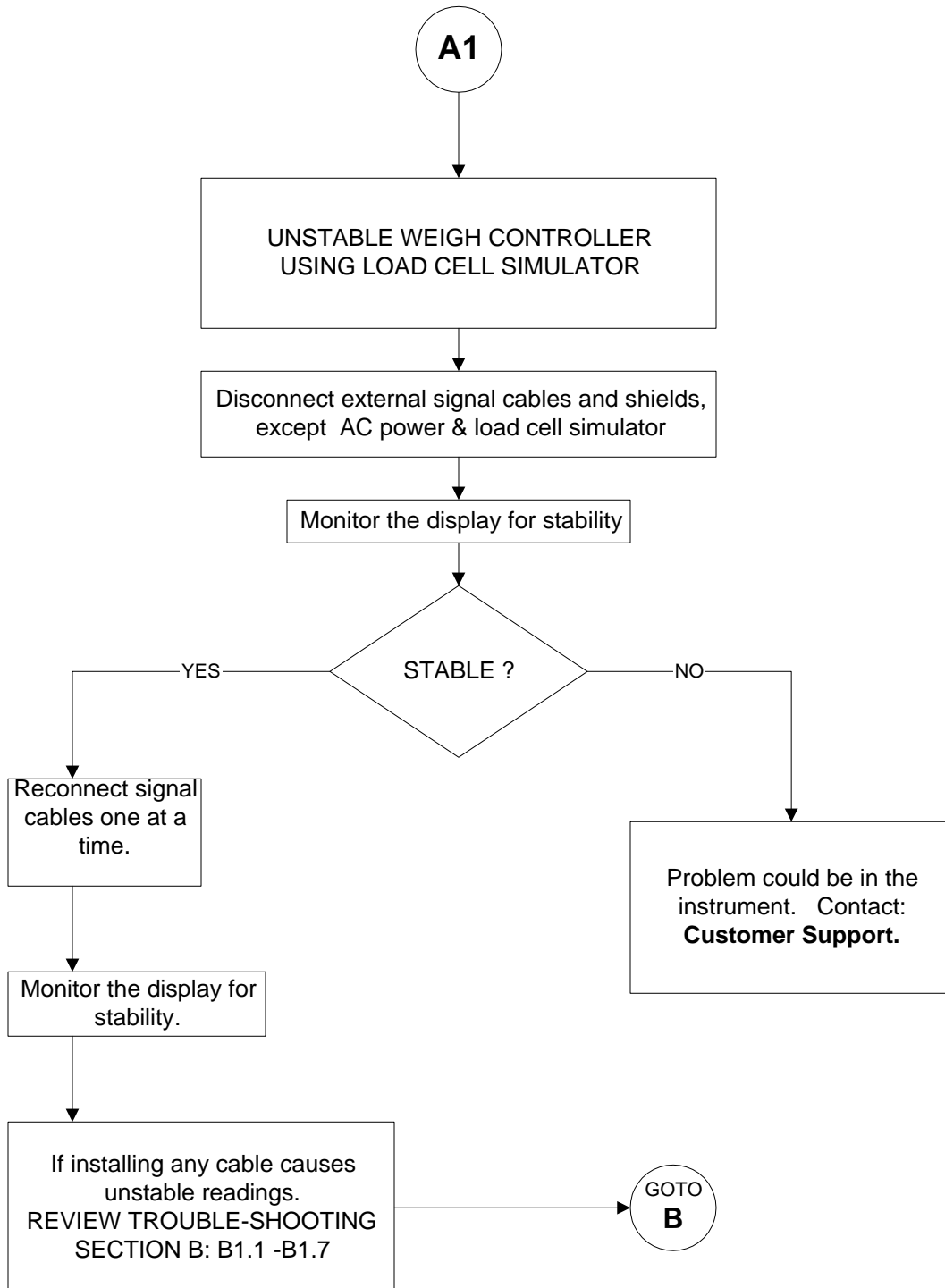

B- Guidelines for Instabilities on Formerly Operating Systems (Cont'd)

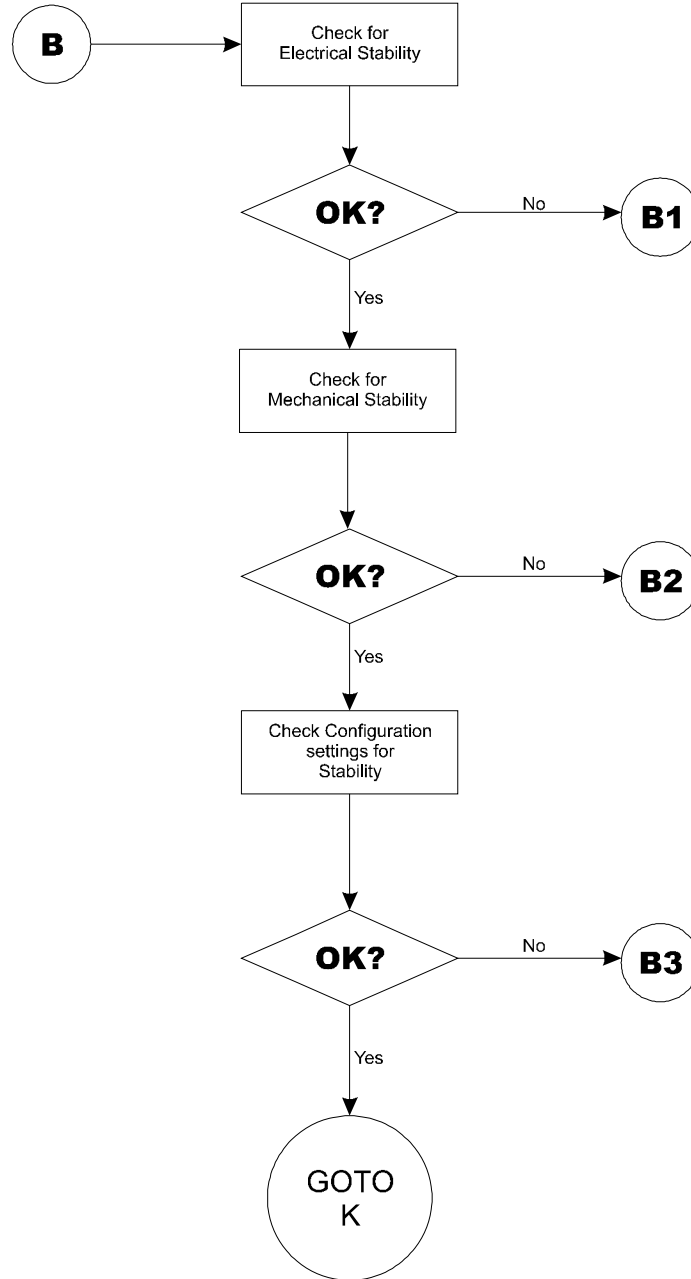

B1 - Guidelines for Instabilities on Former Operating Systems (Cont'd)

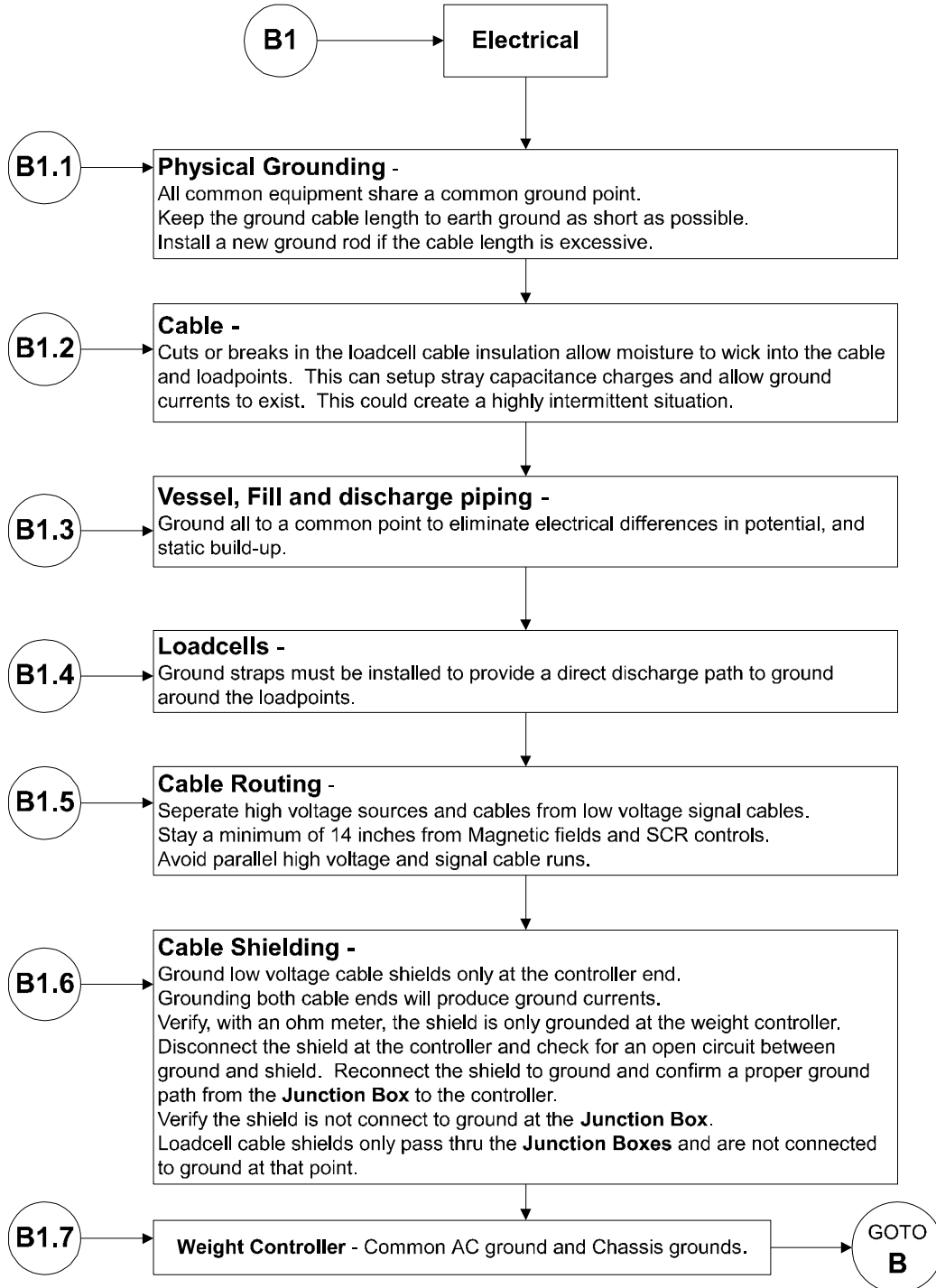

B2- Guidelines for Instabilities on Formerly Operating Systems: Mechanical Stability and Configuration Settings

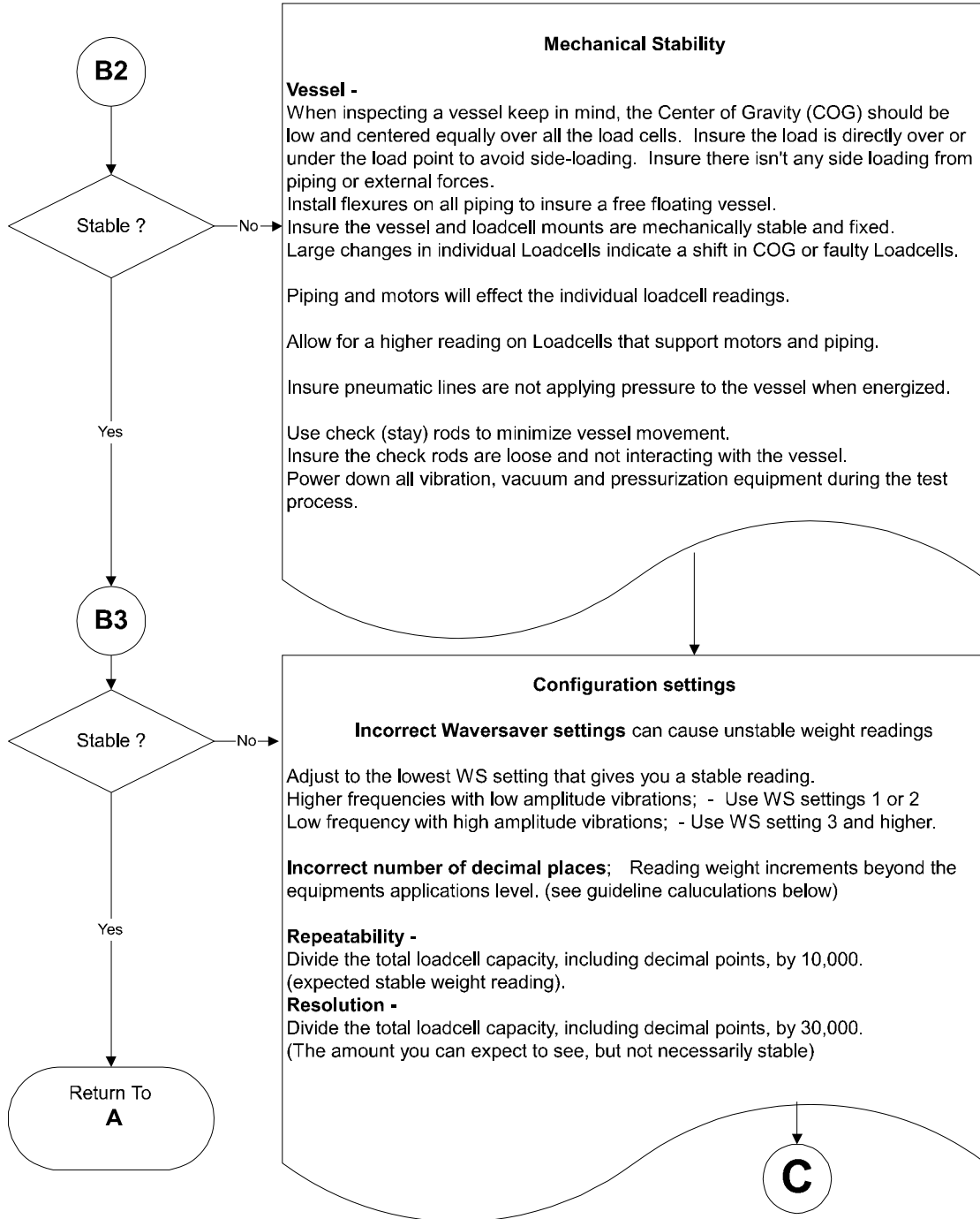

C - Guidelines for Instabilities on Formerly Operating Systems

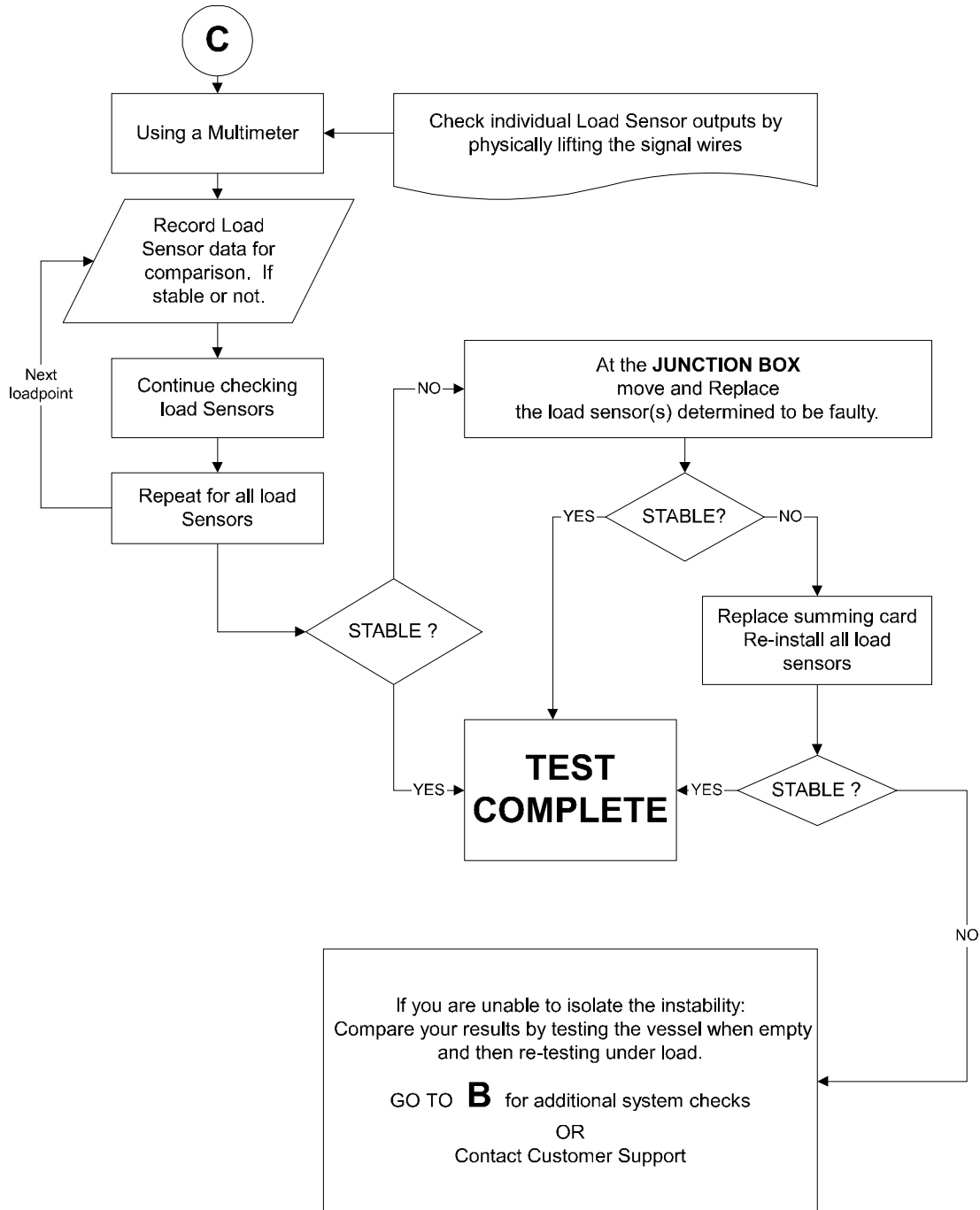

E - Non-Return to ZERO

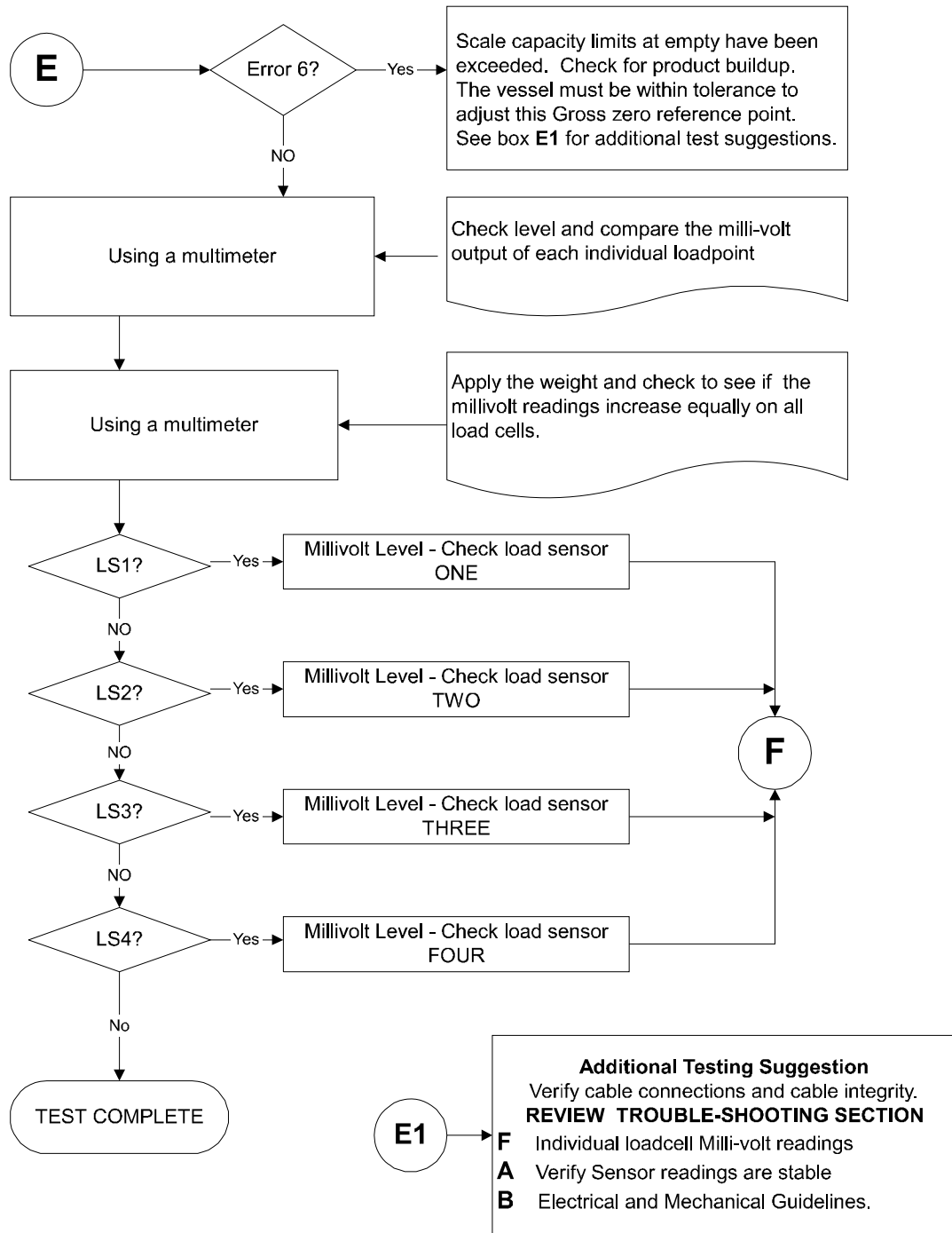

F - Verify Individual Load Cell Milli-Volt Readings

Using the load cell certificate, verify the Milli volt per volt rating
Example: 3 mV/V load cells will produce approximately 15 mV at full load.
 That is 5 volts excitation X 3 mV/V. A scale capacity of 1,000 lbs with 100 lbs
 of deadload at empty the loadpoint mV reading should equal 1.5 mV.

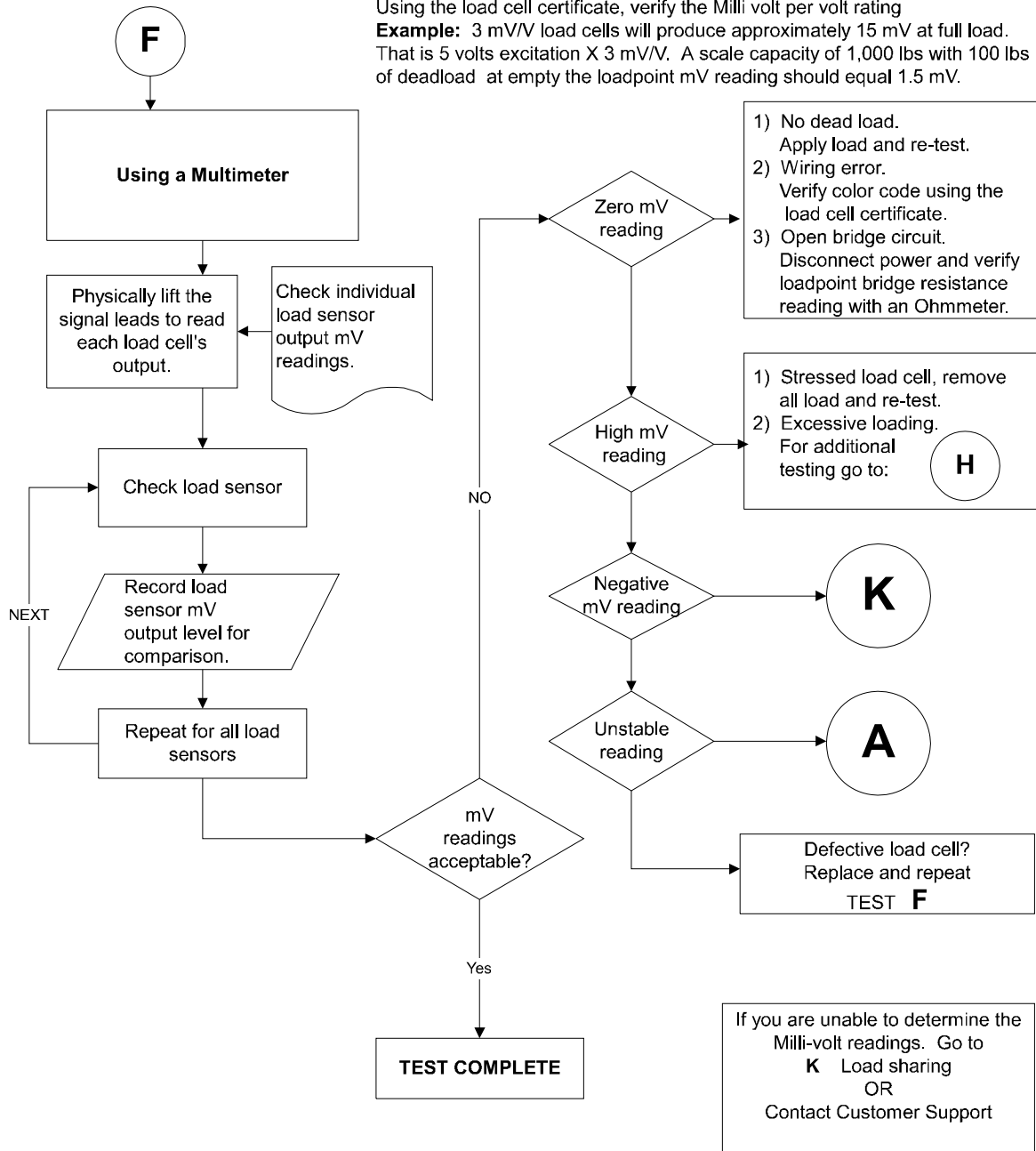

G - Error 18 During Hard Calibration

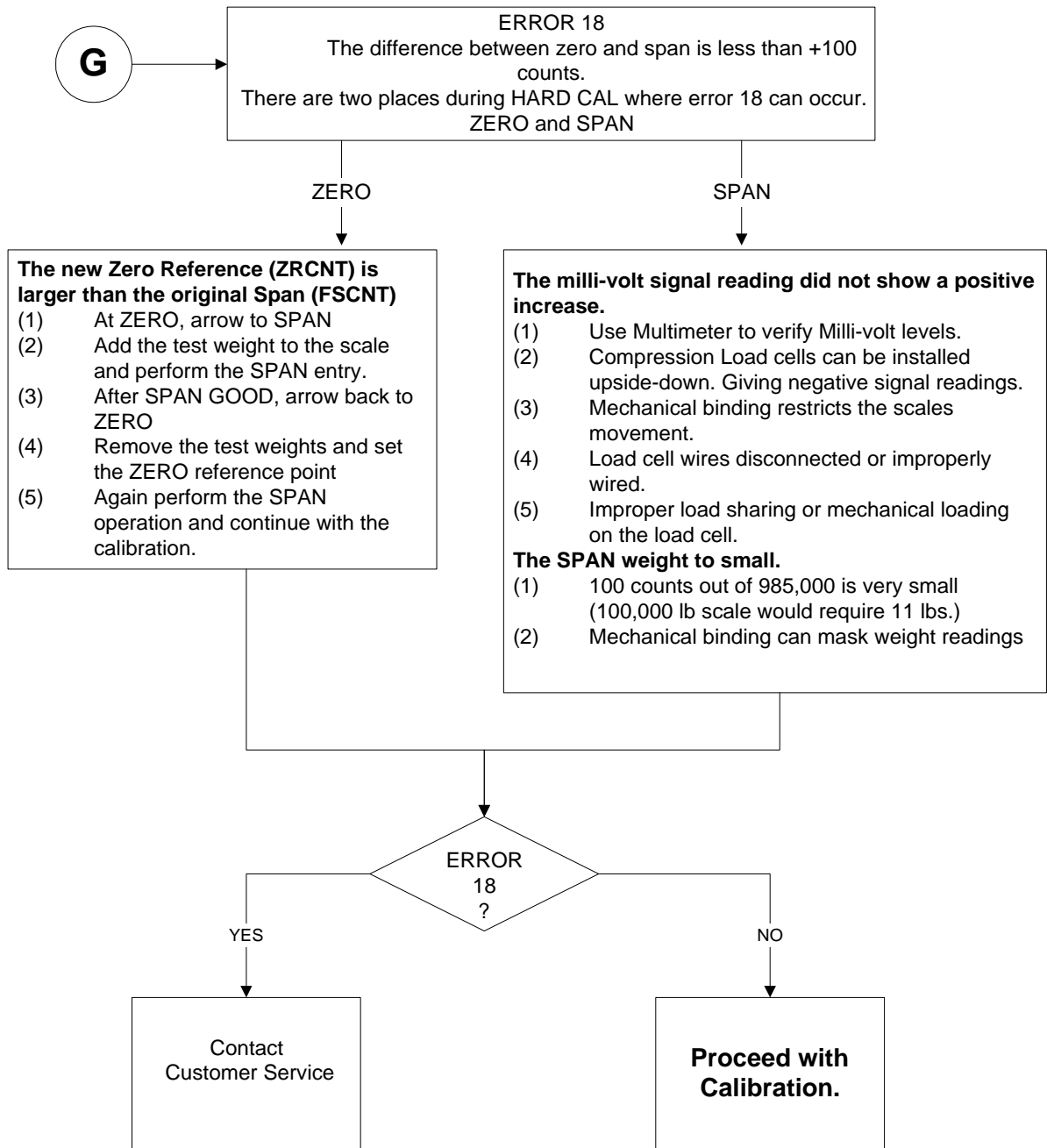

H - Mechanical Inspection

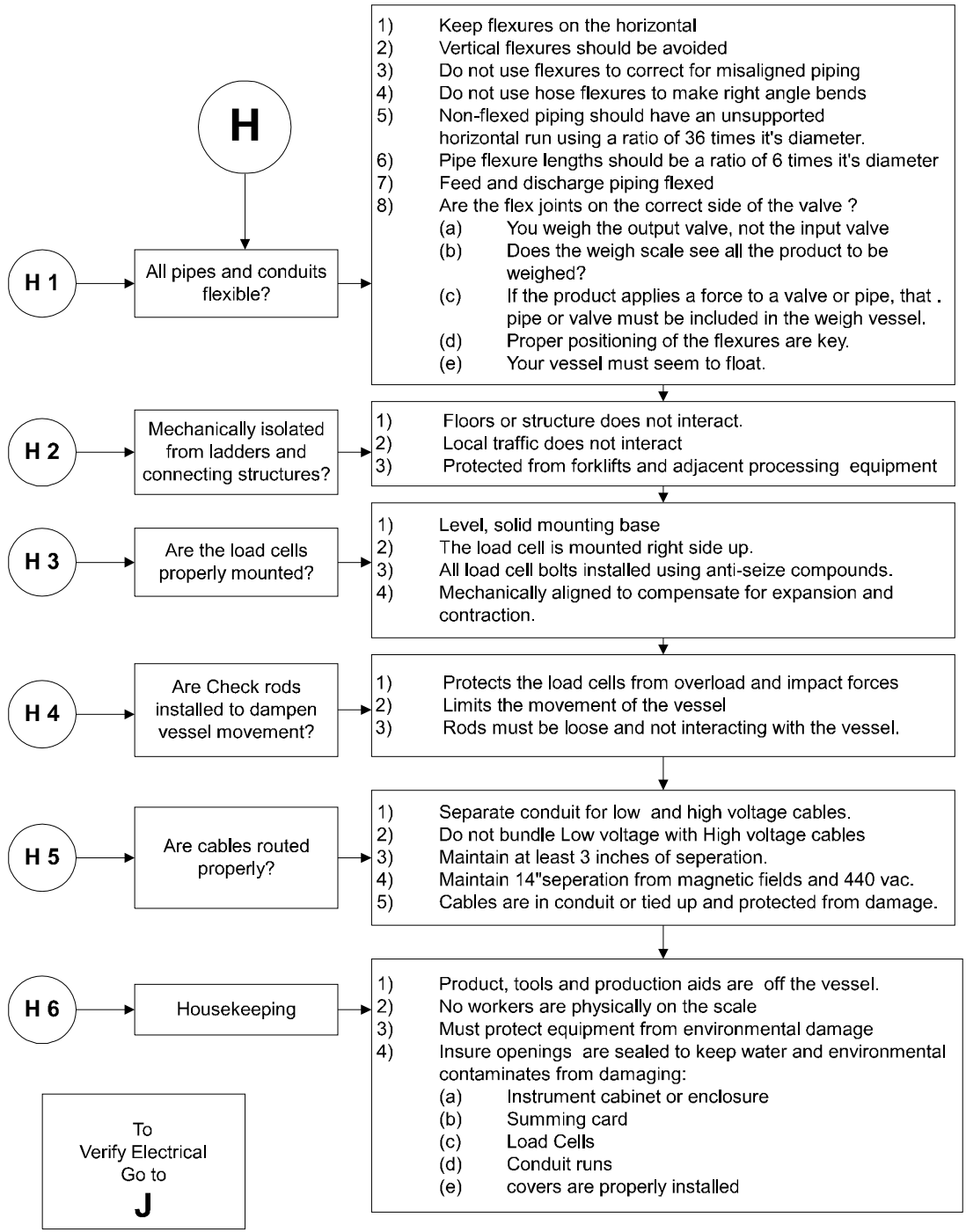

J - Electrical Inspection

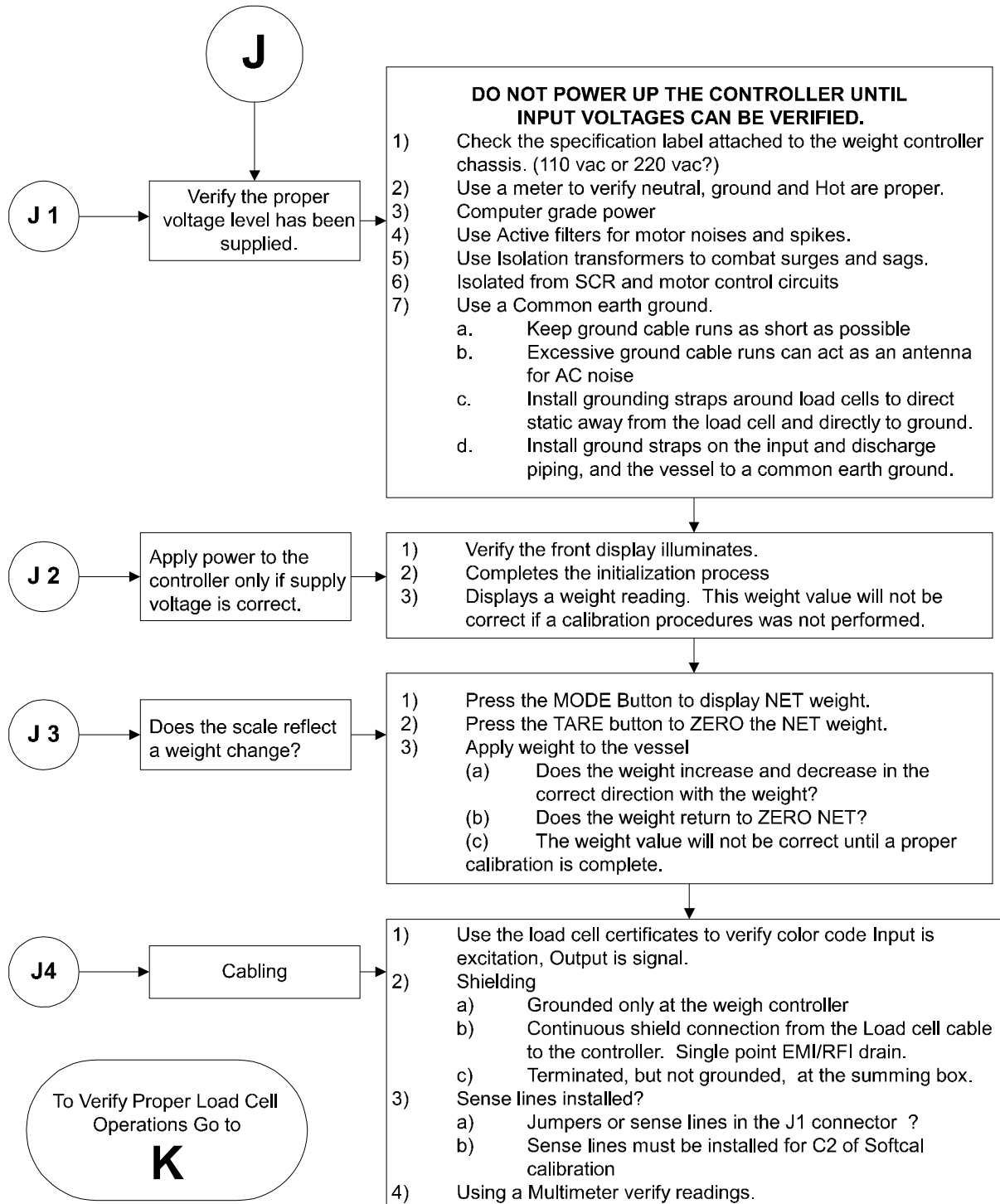

K - Load Sharing and Load Sensor Checkout

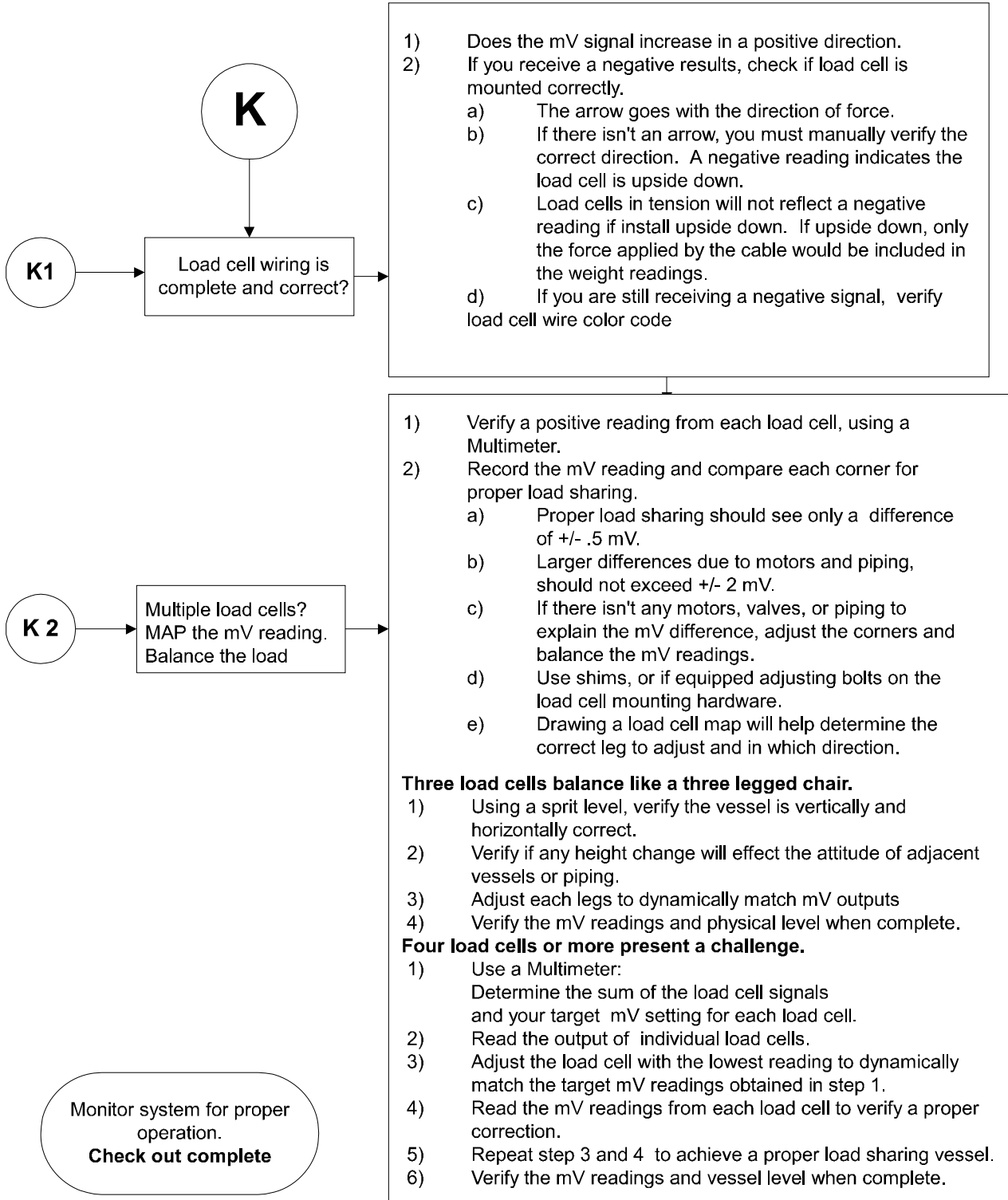

M - HI Error

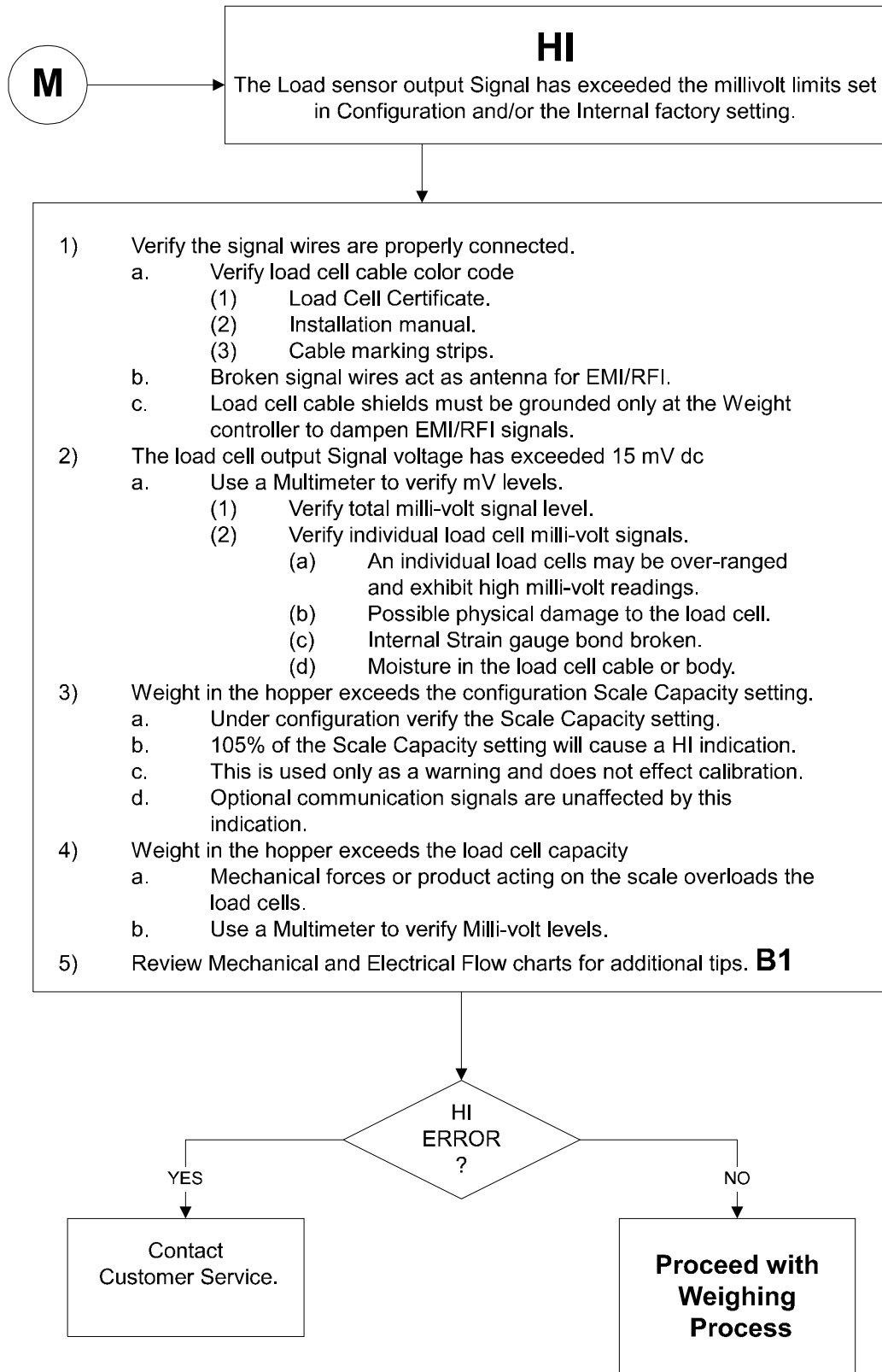

N - Blank Screen

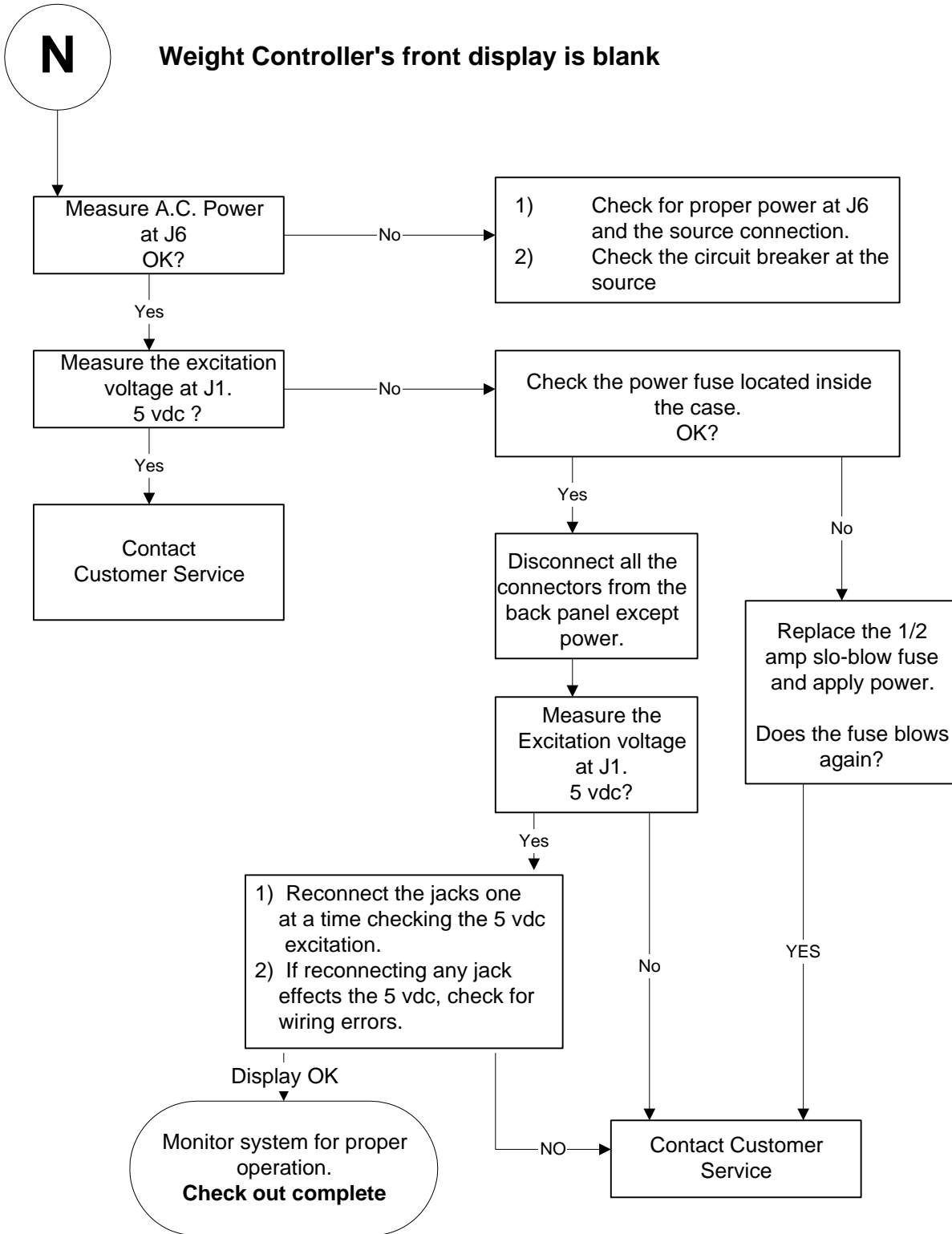

System Integrity Check and Fault Determination

To determine if an instrument or cabling problem exists, verify the basic operation of the system by performing the following system checks.

Self-Test

1. Self-test can be entered only from the net, gross or rate of change operating modes.
2. To initiate self-test, press the -/Test/Clr button.
3. Press the Enter button.
4. The name of each test is displayed for about 2 seconds after which the result is displayed for another 2 seconds. The self-test program automatically steps through each test and continues through any failed tests until all are completed.
5. When the self-test program has completed all tests, the instrument returns to the keyboard test, which can be ended by pressing the 0/ exit button.
6. Speed up the self-test by holding down the UP arrow key. Pause the self-test display by pressing the down arrow key. To resume the self-test, press the up arrow key. To exit the self-test at any time, press the exit key.
7. Write down the test results and compare them to the System Data Survey Sheet. Determine if any differences are due to system modifications, and update the Survey Sheet.
8. Following are the sequential tests conducted by the self-test program:

<u>DISPLAY</u>	<u>TEST</u>	<u>FAILURE SOLUTIONS</u>
SLFTEST	Indicates beginning of self-test.	None
VER X.XX	Version of EPROM installed.	None
8.8.8.8.8.8	Display Test - All segments and words on display turned on.	<ol style="list-style-type: none"> 1. Main card not seated properly in display board. 2. Contamination on connector pins. 3. LED display not functioning.
RAMTST	Ram Test - Writes to each location in RAM & reads back and verifies data. Test is non-destructive.	None
PASSED or	Indicates whether RAM test passed	With most RAM failures system will not operate.

HI 2110WI WEIGHT CONTROLLER

<u>DISPLAY</u>	<u>TEST</u>	<u>FAILURE SOLUTIONS</u>
FAILED	Failed.	1. Check that EPROM (U13) on main board is seated. 2. Contact Hardy Instruments for assistance.
CAL TYP	How instrument was calibrated	None
NOTE:	<i>One of the next three messages will be displayed, depending on the type of calibration that was performed.</i>	
C2 CAL	C2TM Second Generation Calibration	None
H CAL	Hardware Calibration	None
S CAL	Software Calibration	None
UNITS	Indicates next parameter will be units of measure.	None
KGS or LBS	Kilograms or pounds.	Default is Lb.
WSVR = 4	Indicates Waversaver that was selected In Calibration	Default is 4.
GRAD	Indicates next parameter will be graduation size.	None
1 or 2 or 5 etc.	Graduation size calibrated in unit (least significant digit on display will change by this amount).	Default is 1.
SPAN	Indicates next parameter will be Span.	None
10000	Span value calibrated in unit. (example)	Default is 10,000.
ZR CNT	Indicates next parameter will be A to D counts representing the Zero Count.	--
36780 (example)	A to D counts that indicate the calibrated Zero.	Default is 36780.
FS CNT	Indicates next parameter will be Full Scale Count. 0 in most significant digit indicate value >1,000,000.	None

<u>DISPLAY</u>	<u>TEST</u>	<u>FAILURE SOLUTIONS</u>
992000 (example)	A to D counts that indicate the Calibrated Span Value.	Default is 992000.
SC CAP	Indicates next parameter will be Scale Capacity.	None
999999 (example)	Scale capacity value calibrated in unit.	Default is 10,000.
0 TOL	Indicates next parameter will be Zero Tolerance.	None
10 (example)	Zero Tolerance value calibrated in unit.	Default is 10.
AO TOL	Indicates next parameter will be Auto Zero Tolerance	None
10	Auto Zero Tolerance set during calibration	None
MOTION	Indicates next parameter will be motion value.	None
3 (example)	Motion value calibrated in unit.	Default is 3.
AVRAGE	Indicates next display will be number of values set in the running average table (1 - 200).	None
100 (example)	Number of values set up to be averaged.	Default is 100.
LINCOR	Indicates next display will be single point linear correction.	None
0 (example)	If 0, linear correction is not used. Number other than 0 indicates single-point calibrated value.	Default is 0.
AD OFF	Indicates next display will be A to D Off Set.	None
28912	A to D Offset Value.	None
ADGAIN	Indicates next value will be A to D gain.	None
828238	A to D Gain Value	None

HI 2110WI WEIGHT CONTROLLER

DISPLAY

TEST

FAILURE SOLUTIONS

DIP 1 Indicates next display will be settings of rear panel Config dipswitch S3 segments. Settings represented by hexadecimal notation. If value is other than desired, reset dipswitch segment and retest.

00 thru FF

SWITCH
POSIT.

VALUE

ON

OFF

2	01	Cal toggle	Cal toggle
4	02	Opt menu lock	No opt menu lock
5	04	S.P. menu lock	no S.P. menu lock
7	08	Tare, lb/kg, N/G, lock	zero Keys not locked
8	10	Zero track on	Zero track off
6	20	Spare	Spare
3	40	Serial requests only	All serial I/O
1	80	P2 multidrop	Not multidrop

DIP 2 Indicates next display will be settings of internal dipswitch S2 on power relay board. Settings represented by hexadecimal notation. If value is other than desired, reset dipswitch segment and retest.

00 thru FF

Dip Switch #2

SWITCH
POSIT.

VALUE

ON

OFF

8	01	Spare
7	02	Spare
4	04	NBS Re-Call toggle switch
1	08	Spare
2	10	Spare
3	20	NBS
5	40	Spare
6	80	Spare

LC CNT = 0 - 4

SN1 xxxx-xxxx

“ “ “

SN4 xxxx-xxxx

NOTE:

LC CNT SN1 through SN4 is for C2 only.

<u>DISPLAY</u>	<u>TEST</u>	<u>FAILURE SOLUTIONS</u>
TAG 1	Indicates next display will be value of software control options. Settings represented by hexadecimal notation.	If options are not as desired, another memory key must be ordered. Contact the Customer Support Department.
KEY - BD	Indicates next display will be the keyboard test. Ensure the keyboard operates properly by pressing each key, starting with the ZERO key in the upper left corner of the keypad and moving from left to right. The LED will display each key as it is pressed. Do not press the 0/exit key until you are ready to leave the keyboard test.	

Press the Exit key to resume weighing mode of operation.

**Interpreting Diagnostic/
error Messages**

These techniques are limited to external observations. Checking of internal test points and voltages requires special test equipment and exposure of the circuit cards during normal operation. This should only be done by qualified technicians.

**Overview of Typical
Load Cell System**

1. The typical system consists of one or more load cells/points, a summing junction box, and a weight controller (the HI 2110WC). (See Figure 8-1).

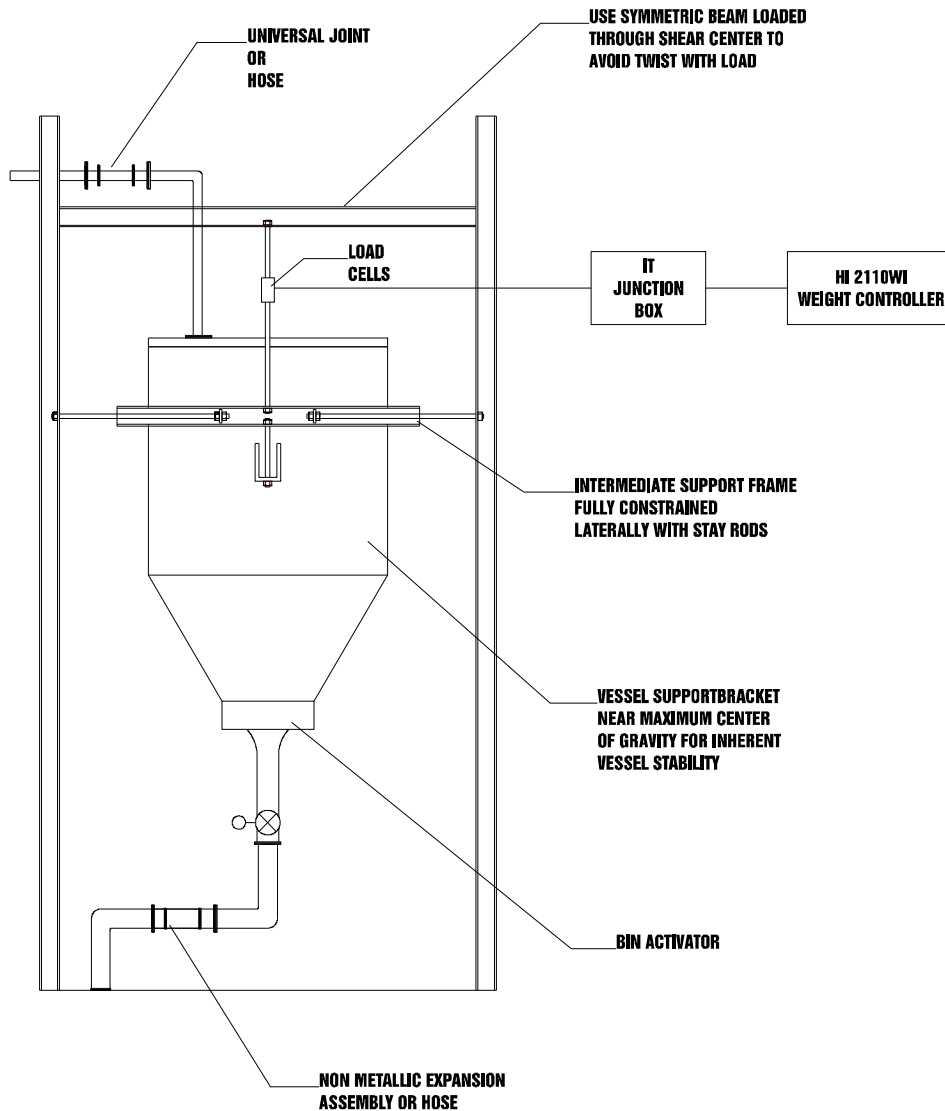

FIG. 8-1 TYPICAL LOAD CELL SYSTEM

- a. Load Cell/Sensor/Point - is a strain gauge based force transducer, which generates an electrical signal proportional to the load applied to the scale. Load cells/points can be used any place a person needs to measure pressure, load, or torque. This can be accomplished by either Tension or Compression type load cells/points. The load cell/point takes as an input the 5 volts DC Excitation Voltage generated by the HI 2110WI, and depending upon how much weight is applied to the scale, generates a millivolt output (proportional to the weight, 0-10mv DC for 2mv/V load cells/points or 0-15mv DC for 3mv/V load cells/points).
- b. Weight Controller - is an electronic instrument which, among other functions, is used primarily to power the load cell(s)/ point(s), take the millivolt signal output from the load cell(s)/

point(s), and digitize, interpret, communicate and display the results as a weight indication.

No Keypad Operation

1. Config dipswitch S3 set to keypad lockout; reposition switch.
2. Check for "HI" on display. Whenever "HI" is displayed, the keypad will be disabled except for the Cal Menu and the -/Test/Clr buttons.

Remote Functions Non-Operational

1. Check wiring at J2.
2. Ensure correct ground is used (J2 pins 9 or 10).
3. Check for correct setting of Config dipswitch S3, See Chapter 4, Configuration.

NOTE:

The HI 2110WI should have a quality power conditioning product installed between the controller and the AC power source to reduce the likelihood of faults caused by poor or intermittent AC power.

Error Messages and Definitions

Error Message

Definition

-- HI --

Load cell/point signal represents a weight higher than scale capacity.

Error

Invalid character entry.

Err 1

Invalid grad size. Grad size must be 1, 2, 5, 10, 20, 50, 100, 200, 500.

Err 2

NTEP grad size error. Grad size must be greater than the full scale divided by the range.

Err 3

Average out of range. Average must be from 1 to 200.

Err 4

Instrument in motion when value entered.

Err 5

Not in Gross mode when trying to enter CAL menu.

Err 6

Invalid zero. Zero must be less than zero tolerance.

Err 7

Invalid grad size. Grad size must be greater than the full scale divided by the range minus one valid grad size.

Err 8

Unable to enter Calibration Menu without toggling ReCal segment on S3 or using the proper security code.

Err 9

Invalid zero. When the instrument is in NTEP mode, the zero must be within the zero tolerance.

<u>Error Message</u>	<u>Definition</u>
Err 10	Invalid motion tolerance. Motion must be greater than 0 and greater than or equal to Grad Size.
Err 11	Negative gross weight during acquire tare. (NTEP only)
Err 12	All decades after decimal point must be active. (NTEP only)
Err 13	Full scale calibration of zero or negative value not allowed.
Err 14	Scale capacity of zero or at negative value not allowed.
Err 15	Zero tolerance of zero or a negative value not allowed.
Err 16	Tare greater than span. (NTEP only)
Err 17	Acquire tare cannot be used with zero gross weight. (NTEP only)
Err 18	Difference between zero and span less than 100 counts in the positive direction.
Err 41	Software Cal reference point weight out of range.
Err 42	Software Cal load cell overloaded.
Err 43	Software Cal range is zero error.
Err 44	Sensitivity out of range.
Err 45	No Software Cal in NBS range.
Err 50	Too many BCD Options.
Err 54	Invalid serial or BCD format entry. (_____ P or _____)
Err 55	Illegal analog weight span. Analog span weight minus analog zero weight must be larger than 2% of the calibrated span.
Err 60	The number of load points found did not match the number entered.
Err 61	No load points found.
Err 62	Load point capacities or sensitivities do not match.
Err 63	Check Sum Error on 1 or more load points.

Error Message

Definition

Err 64

Too many significant digits, after the decimal point, to be displayed.

Err 97

Checksum error.

Err 99

Bad command sequence. (Serial Port only)

SYSTEM DATA SURVEY SHEET

TO: Hardy Instruments Inc. FROM: _____
ATTN: Customer Support COMPANY: _____
FAX NO: 858-278-6700 DATE: _____

Make a copy of this page and store it in a safe place. This information helps us assist you if, for any reason you need to consult Hardy Instruments Inc.

DATE OF INSTALLATION: _____

INSTRUMENT MODEL NUMBER: _____

INSTRUMENT SERIAL NUMBER: _____

(The serial number is located on the back panel of the instrument)

CORNER FREQUENCY SELECTED: _____

LOAD CELLS: _____

Model #: _____

Rated Capacity: _____

Number of Load Cells: _____

mv/V Rating: _____

Type of Vessel/Hopper: _____

Deadload or weight of vessel: _____

RESULTS OF SELF-TEST: Press the -/Test/Clr button on the keypad while in the operating mode, and record the results on the following page. Use the down arrow to pause the display, and the up arrow to resume the self-test.

SELF TEST DISPLAY

SELF-TEST DISPLAY YOUR RESULTS

EPROM# _____

VER _____

CALDAT:

CALTYP _____

UNITS _____

WSVR _____

GRAD _____

SPAN _____

ZR CNT _____

FS CNT _____

0 TOL _____

A0 TOL _____

MOTION _____

AVRAGE _____

LINCOR _____

DIP 1 _____

DIP 2 _____

TAG 1 _____

TAG 2 _____

HI 2110WI WEIGHT CONTROLLER

OPTIONS: Press the 7/Option key to enter the options menu and record the results. (The order of parameters may vary from this list, depending on which options were installed.)

OPTIONS

ROC

UNITS _____

TBASE _____

BARGR

BAR - LO _____

BAR - HI _____

BCD

FORMAT _____

AN OUT 1

AN OUT 2

AN LO _____

AN HI _____

SERIAL PORT

SERCON [] Print
[] bi-dir

BAUD _____

PARITY [] odd
[] even
[] none

STOPS [] 1 bit
[] 2 bits

LENGTH [] 7 bits
[] 8 bits

FORMAT _____

CONTRL [] softre
[] hardre

ECHO [] On
[] off

ADDRES _____

RIO

RATE _____

RAC NO _____

OTR NO _____

L-OTR _____

SETPOINT MENU: Press the 6/Set Pt. key to enter the Setpoint menu and record settings.

SETPOINT MENU

SEtPnt/rLY	1	2	3	4	5	6	7	8
MODE								
SPNT -								
DBND -								
PRE -								

PRINTER INFORMATION

Make and Model #: _____

Baud Rate: _____

Parity: _____

Stop Bits: _____

Length: _____

Format: _____

MISCELLANEOUS INFORMATION

Format: _____

Control: _____

* Address: _____

* Configured with Hardy-Link _____

GLOSSARY OF TERMS

Accuracy	Closeness of a reading to the actual value of the quantity being measured. ALARM - Indication of a tolerance deviation.
Analog Shield Can	A metal enclosure placed over the analog section of the electronics to prevent radio frequency interference.
Analog Transmitter	An option card which outputs an analog representation of net, gross, total weight or rate of change data.
Appurtenance	Any added equipment other than the weigh vessel, platform scale or feeder.
Baud Rate	Baud rates are used as a measure of how fast serial data is transmitted, (BIT/SEC).
BCD	Binary Coded Decimal - a type of positional value code in which each decimal digit is binary coded into 4-bit "words".
Bi-Directional	A capability used to transmit data in either direction at the same time, for example: to or from the instrument.
Clear Key	A key used to clear data or formats entered into a menu.
CTS	Clear to send an RS-232C level signaling a readiness to accept data.
Dead Band	A value used to prevent relay chatter once the setpoint is reached.
Dead Load	Weight of hopper assembly or platform assembly sitting on top of load cells.
Decimal Point Position	Menu item used to set the decimal point position for all display readouts.
Dip-Switch	A switch installed in a circuit card with several individual switches built in. Used to set different options in a system.
Display	A device used to show information from the instrument.
Engineering Units	Pounds or Kilograms
Electrostatic Discharge (ESD)	Electrostatic Discharge is an electric charge (static electricity) which occurs when an electrically charged object, such as a person, touches the HI 2151/30WC. To avoid damage to personnel and to the unit, a grounded static control wrist strap should always be worn when opening and/or servicing the HI 2151/30WC.
Enter Key	This key is used to accept user input into the memory.
EPROM	Electrically programmable read-only memory.
Error	A message that indicates an unacceptable input has been entered.
Even	A parity configuration.
Excitation	D.C. voltage supplied to the load cell for power.
Full-Scale	Full scale input as defined by instrument and load cell parameters. Example: 3MV/V load cell @ 10 volts = 30mV full scale.
Graduation Size	Minimum increment displayed by the instrument.

HI 2110WI WEIGHT CONTROLLER

Gross Weight	An overall weight exclusive of tare deductions. Weight of material plus container.
Input Average	The number of readings averaged into a displayed value.
Keypad Lockout	A selectable switch used to prevent input from the keyboard.
Kilograms	A unit of mass in the metric system. Equal to 1000 grams or 2.2046 pounds. "Gr" represents kilograms on the display.
LED	Light Emitting Diode. These are used in the front panel displays and indicators.
Load Cell	A device which produces an output signal proportional to the applied weight or force.
Menu	A set of prompts used to configure the instrument.
Menu Driven	Operational prompts supplied in common language statements via the system display to guide an operator through a procedure.
Microprocessor	A semiconductor device that performs control, input/output, arithmetic, and logical operations by executing instructions obtained from memory sources.
Midpoint Linearity Correction	Allows operator to "BEND" the response of an instrument to match a non-linear input.
Motion	The amount of allowable deviation between consecutive readings before a weighment is accepted as being complete.
NEMA 4	An enclosure that is watertight, dust-tight, and usable both indoors and outdoors. Will protect the enclosed equipment against splashing water, seepage of water, falling or hose-directed water, and severe external condensation.
NEMA 4X	An enclosure that is watertight, dust-tight, and usable both indoors and outdoors. Will protect the enclosed equipment against splashing water, seepage of water, falling or hose-directed water, and severe external condensation. Corrosion Resistant.
Net Weight	Gross Weight minus the Tare value.
Next Key	A key used to step through menus or increase the value of a digit.
Non-Linearity	A deviation of an instrument response from a straight line.
Number Of Readings Per Average	The number of weight readings used to compute the displayed weight.
Odd	A parity configuration.
Option	A device not supplied with a standard instrument.
Option Slot	A location on the main board used to install an option card.
Parity	A binary digit error correction appended to an array of bits to make the sum of all the bits always odd or always even.
Pounds	A unit of mass in the Avoirdupois System. Equal to 16 ounces or 0.4536 kilograms.

Preact	The number of units above or below the set point value of which the relay will trip. Use as an "in flight" compensation value.
Previous Key	A key used to step back through menus.
Prompts	Instructions or options presented, in a menu, by the instrument.
RAM	Random-Access-Memory. Read/write memory out of which the microprocessor can both write and read data.
Rate of Change	A measure of the rate at which weight is changing. For example, if 100 pounds were dispensed in 1 minute the rate of change would be 100 lb/minute.
Relay Sense Selection	Optional procedure which reverses the relay sense from normally energized to normally de-energized, or back again.
Remote Function	A function in the instrument that can be accessed away from the instrument.
Repeatability	The maximum difference between readings for repeated readings under identical conditions.
ROM	Read-Only-Memory. This permanent, non-volatile memory gives the processor instructions and cannot be altered.
RTS	Request to send an RS-232C level, signaling a readiness to send.
RXD	Received data at a serial port. Accepts RS-232C data signals.
Scale Capacity	The maximum amount of weight the scale is capable of supporting, (Live load plus deadload).
Secure Memory Module (SMM)	The Secure Memory Module stores and protects vital information from corruption, including calibration, configuration of setpoints, RS-232C Serial Port, Optional Serial, BCD, Bar-graph, and Rate of Change. Also allows the transference of data from one unit to another, with no re-calibration or re-configuration necessary.
Set Point	Ordered weight of a particular ingredient. Weight reading at which a relay will be actuated.
Span	The total amount of test weights used (placed on the scale) when performing a "Hard Calibration".
Tag	Another name for Secure Memory Module.
Tare	Artificial zeroing of the weight hopper so that a net weight can be displayed. Also, the action of adjusting out the known weight of the container from the total indicated weight, so that the indicator reads net weight directly.
Temperature Coefficient	The change in indication due solely to a change in temperature from a reference temperature. Expressed as a percentage of span value for a specified temperature change.
Time Base	Time in seconds between values subtracted to determine rate of change.
Transmitter Span	Value the transmitter puts out with the maximum weight on the load cell.
Transmitter Zero	Value the transmitter puts out with minimum weight on the load cell.

HI 2110WI WEIGHT CONTROLLER

TTL	Transistor-transistor Logic
TXD	Transmit Data
Update Rate	Number of times per second a new weight reading is taken.
Zero	Weight reading once the dead load has been offset.
Zero Calibration	Offset of the value of the dead load of the weight hopper.
Zero Tolerance	The number of graduations from zero that will be accepted as zero by the instrument.
Zero Track	Logic command used to adjust the instrument automatically from small variances in zero readings.